

Q7000-EL

ASYNCHNNOUS INVERTER FOR ELEVATOR

INSTRUCTIONS BROCHURE



Contents

1. Product Introduction(Notice)(Security Precaution in Operation).....	3
2. Product Inspection (Technical Support).....	4
2.1 Type Description:	4
3. Installation and Use	4
3.1 Operating Environment	4
4. Wiring Diagram.....	5
4.1 Basic Wiring Diagram	5
4.2 Terminal Blocks Wiring Diagram	6
4.3 Control Loop Terminal Blocks Function Description	7
4.4 The application of peripheral equipment and precautions	8
4.5 Application Examples	9
5. Run Test	11
5.1 Check before Run	11
5.2 Commissioning Test:	11
5.3 Selection of Run Methods:	11
5.4 Setting before Run:	12
6. Setting Control Method	12
6.1 Features of Control Methods	12
6.2 Selecting Control Method	13
6.3 Display and Operation Control Functions of the Digital Operator	14
6.4 Description of Keys of the Digital Operator:	14
6.5 Changing Control Methods:	15
6.6 EASY-TUNING Procedure	16
6.7 The Fault Display When Performing EASY-TUNING and the Countermeasure	18
7. Detailed Description on Parameter Groups	19
7.1 1 Parameter Group.....	19
7.2 2 Parameter Group.....	20
7.3 3 Parameter Group	27
7.4 Parameter Group	32
7.5 5 Parameter Group	36

7.51	V/F Control Method [Fixed Curve 0-E]	37
7.6	6 Parameter Group	39
7.7	T Parameter Group.....	40
7.8	Parameter Group	54
7.81	Detection Act Description of Frequency Detection Relationship	57
7.9	O Parameter Group	60
7.91	Set Value List of Multifunction Input/Output Terminals	63
7.92	Set Values before Leaving Factory	64
7.93	The List of Specification Parameters	65
7.94	The List of Simple Parameters.....	66
8.	The description of malfunction and countermeasures of the frequency converter ...	79
8.1	External braking resistor selection	83
8.2	External physical dimension of converter.....	84
9.	Form of standard specification	85
	440 V Grade Specification List	85

1. *Product Introduction*

Thank you for purchasing Q-7000-EL Current Torque Vector Control General-Purpose Inverters developed by Qma Technical Company, featuring high performance and low noise. Please read this manual thoroughly and carefully to make good use of the performance and functions of this inverter and to keep your safety in operation. Please contact our agents in your regions or technical personnel of engineering department in our company if any problem you can't solve by referring to the manual occurs in operation. Our professionals are ready to help you. You are welcome to use our products.

[Notice]:

“Danger” “Caution” in the manual prospect you the security precautions in moving, installing, operating and checking.

[Danger]: The misuse may lead to personal injury. Please don't take down, install or change the internal parts, circuitries or links of the inverter without permission.

[Caution]: The misuse may lead to the damage of the inverter or mechanical system.

<p>[Danger]:</p> <ul style="list-style-type: none"> • Please don't touch circuit boards, parts or components after power-off before the “Charge” led is off. • Please don't take down, install or change the internal parts, circuits or links without permission in the inverter. • Please don't take wiring when power is supplied; please don't check the components, parts or signals on the circuit board when the inverter is running. • Please correctly ground the earth terminals of the inverter: 220V terminal: the third grounding; 440V: special grounding.

<p>[Caution]:</p> <ul style="list-style-type: none"> • Please don't carry on withstand voltage test on internal parts or components of the inverter, because these semi-conduct parts or components are subject to be damaged by high voltage. • You mustn't connect the output terminals of the inverter U, V, W to the input terminals AC power source (R, S, T). • Pleas don't touch the main circuit board for the CMOSIC component on the circuit board of the inverter is subject to affected or damaged by static electricity

[Security Precaution in Operation]

<p>Danger</p>
<ul style="list-style-type: none"> • Please don't take off the front cover when the inverter is powered for fear of electric shock • Please don't approach to the machine if you set the automatic restart function, because the motor will be restarted after the machine stop. • The “Stop” switch function is available after setting. It is different from urgent “Stop” switch in use, please pay attention to it.

<p>Caution</p>
<ul style="list-style-type: none"> • Please don't touch the hot components such as radiator and brake resistor for fear of scald and electric shock. • Please input the permissible range of the motor and the machine, because it is easy for the inverter to rise speed from low to high. • Please pay attention to the relative settings when using the brake. • Please don't test the signal on the circuit board when the inverter is running. • Please don't discretionarily adjust the parameters, because the inverter was set well before leaving factor.

2. Product Inspection

Every Q-7000-EL inverter has passed function test before leaving factory. The clients should carry out the following check steps upon delivery and unsealed.

- If the type and capacity of inverter are the ones you want;
- If the inverter was damaged during delivery, if so, please don't power it;
- Please inform the local agents, technical personnel of Qma Technical Company for any above problem
- Or contact service department for technical support. Thank you again for using our products.

2.1 Type Description:

Nameplate Information: (Example: AC220V, L15HP,11KW-49A)

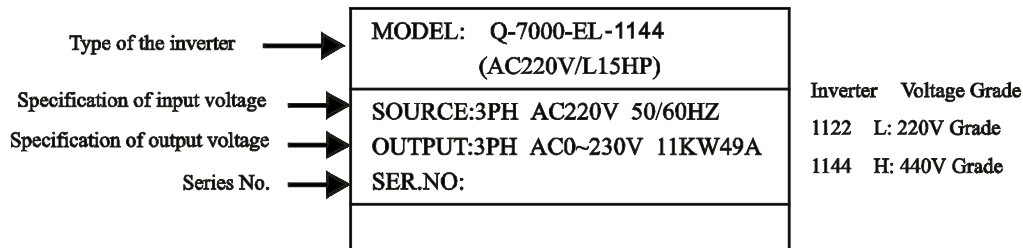

3. Installation and Use

3.1 Operating Environment

The installation environment, which has direct influence the functions and service life of the inverter, should meet the following conditions:

- environmental temperature: Panel inner opening: (+10~45°C/+14 ~113°F)
- Prevents from rain and moisture .
- Avoids direct sunlight.
- Prevents from oil spray or corrosion by salt.
- Prevents from corrosive liquid or gas.
- Prevents from the invade of dust, batt, and fine metal scraps.
- Be far away from radioactive substance and combustible substance.
- Prevents from EMI (from sealing machines or power machine for example).
- Prevents from vibrations. Please use shims to absorb librations if necessary.
- Several inverters are installed in a control board, please correctly lay out them for better heat emission. A fan should be equipped to keep the temperature below 45.
- The face of the inverter should face front for better heat emission.
- The installation space must comply with relative regulations (It the inverter is installed in the control board or the environment is permitted, the upper dust cover can be took off for better heat emission).

4. Wiring Diagram

4.1 Basic Wiring Diagram

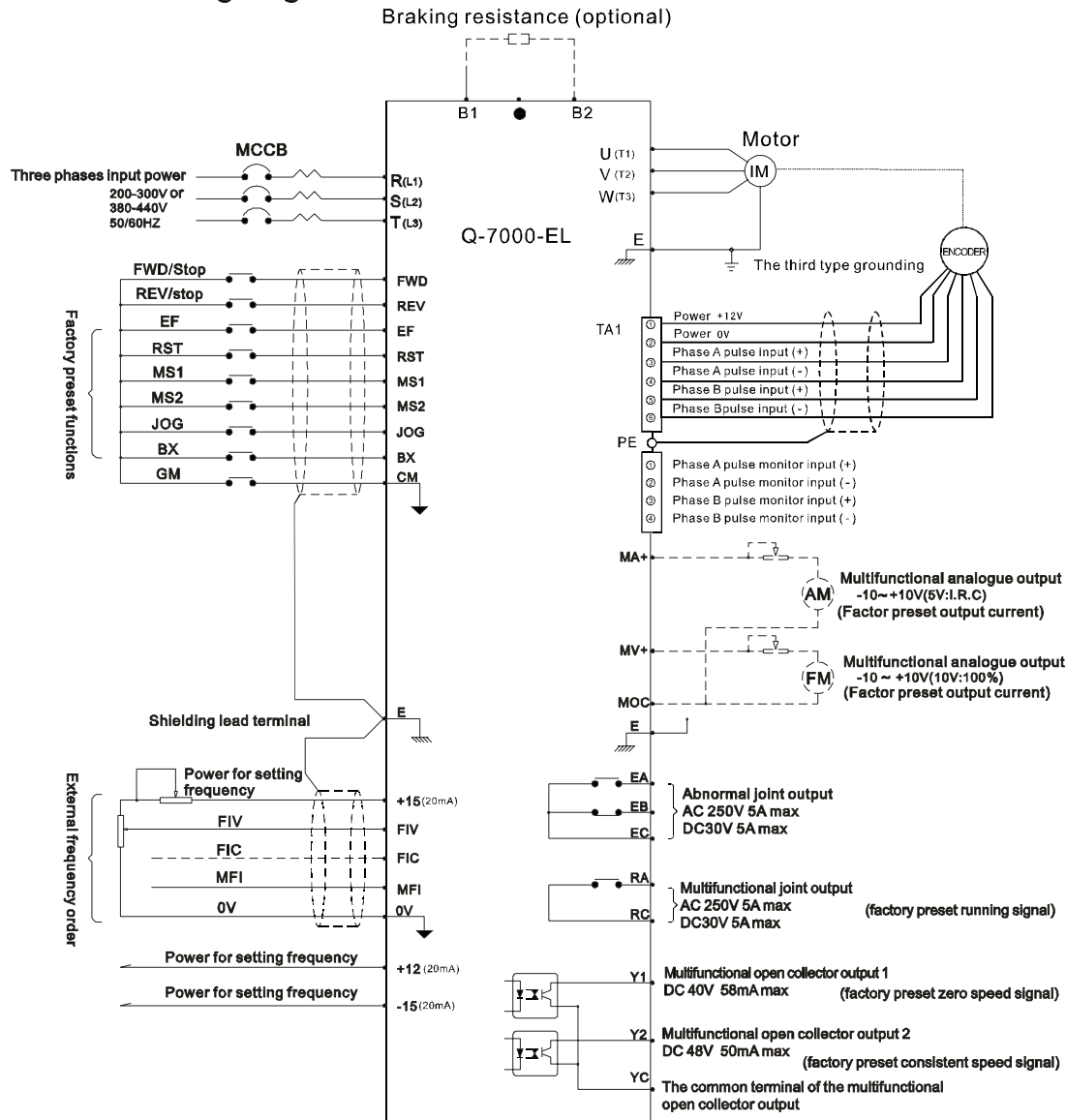

- Note 1: separating harness
- Note 2: terminal blocks +15, +12, -15, 20mA
- Note 3: refers to wiring display cables or doublet cord and twisted pair cables
- Note 4: a. Only shield twist pair cable is used as signal cable.
b. Max length of PG is 100m.
c. The turning direction of PG may be selected by parameter 61-05 and the factory preset value is the phase advancer during the motor is running forward.

* Terminal Blocks Wiring Diagram

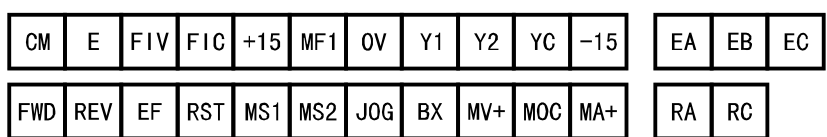

4.2 Terminal Blocks Wiring Diagram

- Functions of terminal blocks of main loop

Terminal	Function
R	Terminals for power input of main loop
S	
T	
B1(P)	DC power source of main loop (DC+ positive voltage)
⊖	DC power source of main loop (DC- negative voltage)
B2	Connection point of brake resistor
U	Output terminals of the inverter
V	
W	

- Functions of terminal blocks of main loop

Terminal	Function
R	Terminals for power input of main loop
S	
T	
B1(P)	Connection point of brake resistor
⊖	DC power source of main loop (DC-negative voltage)
B2	Connection point of brake resistor
U	Output terminals of the inverter
V	
W	
E	Grounding terminal (Especially the third grounding)

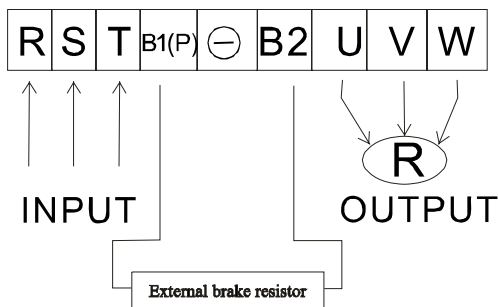

Take 15HP , 20HP as examples

4.3 Control Loop Terminal Blocks Function Description

- Functions of the control loop terminal blocks (leaving factory settings)

Sort	No.	Name	Function of the Terminal		Signal Level	
Run Input Signal	FWD	Forward/Stop	ON Forward, OFF Stop		DC24V, 8mA optical coupling, insulation	
	REV	Reverse/Stop	ON Reverse , OFF Stop			
	EF	External Fault Input	ON Fault ,OFF Normal			
	RST	Fault Reset	ON Reset			
	MS1	Main/Auxiliary speed switch	ON Auxiliary frequency reference			
	MS2	Multi-terminal speed reference	ON Multi-terminal speed reference 2 available			
	JOG	Inching Reference	ON Run with inching method			
	BX	External Stop Running	ON Inverter stop output			
	CM	Common Terminal	Signal output when shortening with FWD- BX			
Analog input signal	+15	Power source for speed reference +15V	Power source terminal for speed reference setting, +15 power source		+15V, 20MA	
	-15	Power source for speed reference -15V	Power source terminal for speed reference setting, -15 power source		-15V, 20MA	
	+12	Power source for speed reference -15V	Power source terminal for speed reference setting, +15 power source		+12V, 20MA	
	FIV	Main speed frequency reference	0-10V/100a% frequency		0-10V,(20KΩ) -10,+10V(20KΩ) 4-20mA,(20Ω)	
	FIC		-10~+10V/-100%~+100% frequency 4-20MA/100% frequency			
	MFI	Auxiliary frequency reference	0-10V/100% frequency -10~+10V/-100%~+100% frequency	Accessorial analog input T3-01-03	0~10V, (20Ω) 0-20mA, (250Ω)	
	OV	Common terminal	The speed reference common terminal for terminal FIV,FIC, and MFI			
E	STP terminal	Connect the shield of jacket of isolated twisted line				
Analog output	RA	Signals output during running (5A connection point)	The terminal is connected during running		Capacity of the connection point AC250V 5A, DC30V 5A	
	RC					
	Y1	Zero speed detection	The lowest frequency is lower than 51-09, LOW level			Open set output, below 48V 50mAbelow
	Y2	Speed arrival detection	Within ±1% of the set frequency , LOW level			
	YC	Common terminal of terminal Y1,Y2				
	EA	Fault output signal EA-EC, A connection point EB-EC, B connection point	When fault EA-EC is off EB-EC is on			Grounding capacity AC250V 5A DC 30V 5A
	EB					
EC						
Analog output	MV+	frequency meter output	0-10V/100% frequency (0~10V/100% current can be set)	Multifunction analog output 1(T4-01,T4-03)	0~+10V Max5% 20mA below	
	MOC	Common terminal				
	MA+	Output current control	5V/ inverter determined current	Multifunction analog output 2 (T4-04,T4-061)		

4.4 The application of peripheral equipment and precautions

Power source :

- Please pay attention to if the voltage is correct to avoid damaging the inverter.
- No-fuse switch must be installed between AC power source and inverter.

No-fuse switch :

- Please adopt no-fuse switch that meets the rated voltage and current of the inverter to control ON/OFF. The inverter should be protected.
- Please don't adopt no-fuse switch as RUN/STOP switch for the inverter.

Residual current circuit breaker :

- Residual current circuit breaker should be added to avoid misact led by electric leakage and to protect the safety of operators.

Electromagnetic contactor :

- The electromagnetic contactor needn't be used in general condition except being used in external control or auto restart function after power break or brake controller.
- Electromagnet contactor can not be used as RUN/STOP switch of the inverter.

AC Reactor for improving the power :

- AC reactors can be added to improve the power of power source with large capacity (600KVA and above) for inverters of 220V/440 15 KW and below.

Noise filter at input side :

- Noise filter must be added if inductive load is used in the peripheral of the inverter.

Inverter :

- There is no phase sequence between terminal R,S,T on input power source terminal blocks, phase change connection is available.
- Connect terminal U,V,W on Input terminal blocks to terminal U,V,W on the motor. If the inverter is forward running but the motor is reverse running, you only need to exchange the connection between two terminals of U,V, or W on the terminal blocks.
- Please don't connect AC power source to the terminal U, V, W on the terminal blocks to avoid the damage of the inverter.
- The grounding terminal E should be connected correctly: 220V grades: the third grounding, 440V grade: special grounding.

Noise filter on the output side :

- Reduce the higher harmonics generated by the inverter to avoid affecting the communication equipment around.

Motor :

- Please adopt three-phase inductive motor meeting capacity of the inverter.
- The value of the current when the all motors work at the same time should be less than the capacity of the inverter if one inverter drives more than one motor.
- Please don't add to capacitance between inverter and motors.
- Inverter and motor(s) should be grounded respectively.

* The followings should be abided by in external wiring. It should be checked up if the wiring is correct after wiring.

(Control loop buzzer should not be used to check up the wiring.)

(A) The loop wiring of main power must be isolated and parted from other high voltage or power line with large current to avoid the disturbance of noise.

- The inverter should use independent power source branch.
- The common noise filter can not guarantee the effect.
- The noise filter special for the inverter or isolating transformer should be equipped if the inverter shares power source loop with other machines.
- The noise filter special for the inverter should be added to the main loop output side to restrain noise transmission. To prevent noise transmission, please add to metal bushing on the loop and the distance apart from other lines conveying signal controlling machines should be moved than 30 cm.
- Please take account of the voltage drop of the circuitry if the wire between the inverter and motor is too long. The voltage drop between phase is $(V) = \sqrt{3} \times \text{wire resistance (} \Omega/\text{km)} \times \text{line length (m)} \times \text{current } 10^{-3}$. The amount of carrier wave should be adjusted according to the wiring distance.

Inverter and the distance of wiring for the motor	Less than 50M	Less than 100 M	More than 100 M
Permitted carrier wave	15KHz and below	10 KHz and below	5KHz and above
Setting value of parameter 36-01	15.0	10.0	5.0

- (B) The wiring of control loop must apart from main loop control wire and other high voltage lines or power lines with large current to avoid noise disturbance.
- The wiring terminal RA, RC, EA, EB or EC (connection output) of control loop should be wired apart from other terminals.
 - To avoid noise disturbance and misact, the control loop should wired with shield isolating twisted wires. The shield twisted wires should be connected to terminal E. The wiring distance should not be more than 50 meters.
- (C) The grounding terminal should be correctly grounded: 220V grade: the third grounding; 440V grade: special grounding.
- The grounding wiring should be according to AWG, the grounding wire should be as short as possible.
 - the grounding wire should be grounded separating from other load with large current (such as welding machines, large power motors).
 - The grounding loop shouldn't be formed if several inverters are grounded at the same time.
- (D) Please select the specifications of wires, the diameters of main power source loop and control loop according to electrical engineering rules to guarantee security.
- (E) After the wiring, please check up the wiring quality such as if the wiring is correct, if the wires are broken or damaged, if the screws of the terminals are turned tightly.

4.5 Application Examples

This section introduces the functions and applying occasions of the inverter.

Function Name	Applying Occasion	Purpose	Function Description	Relative Parameters
3-wire mode	Common occasion	PB performs run, stop, one connection point controls forward/reverse run.	Control the start, stop and forward/reverse run by wiring	11-03 T1-01
Selection of operation signal	Common occasion	Select the source of control signal	Select the external terminals of the inverter or controlled by the numerical digit operator	21-01-02 T1-01-06
Setting of carrier wave frequency	Common occasion	Reduce noise	The frequency of carrier wave of the inverter can be regulated freely to reduce the metal noise of the motor	36-01~03
Showing the load rotation speed	Common occasion	Show the run status	The motor rotation speed (rpm), machine rotation speed (rpm)and machine leaner speed (m/min) can be shown on the digital operator	01~03
In-operation signal output	Common occasion, mechanical brake	Provide run status signal	This signal is put out during the motor is running; the signal will disappear after the mechanical brake is released and the inverter stop running.	T2-01~03
Zero-speed signal output	Common occasion Working machine	Provide run status	when the output frequency is lower than the lowest output frequency, this signal is output to the external system or control circuitry	T2-01~03
Speed arrival signal output	Common occasion, working machine	Provide run status signal	When the output frequency arrives at the set frequency, this signal is put out to the external system or the control circuitry.	T2-01~03
Running between the upper limit and lower limit of the frequency	Pumping Fan	Hold the rotation speed of the motor in the upper and lower frequency	The external running signals can't provide upper and lower limits, which can be specially set and adjusted in the inverter when gain or bias occurs.	42-01~02
Setting forbidden frequency reference	Pumping Fan	Prevent from mechanical vibrations	The inverter can't continuously run in the set forbidden frequencies with fixed speed. You can set three sets of forbidden frequencies.	43-01~04
Undervoltage signal output	Common occasion	Provide running status signal	The voltage at P-N end of inverter side. When the undervoltage is check up, this signal is put out to external system or control system.	T2-01~03
Frequency holding run	Common occasion	Pause the accel/decel	The output keeps invariable when the inverter speeds up or down	T1-01~06
Fault auto restart	Air conditioner	Improve the continuity and reliability of run.	After the fault is checked up, the inverter can restart automatically when the cause of the fault is removed. The restart can be set as 10 times.	P5-01

Function Name	Applying Occasion	Purpose	Function Description	Relative Parameters
DCLNJ urgent stop	High speed shaft	The motor urgently stop without brake resistor	DCLNJ can be used to urgently stop the motor when the brake resistor is not equipped to the inverter while the brake torque is not large enough.	21-03 22-01~04
Over-torque setting	Pumping fan extruding machine	Protect machines, improve the continuity and reliability of running	The machine over-torque detection norm byte can be set in the inverter or motor. It is fit for non-jump running of wind power machines or hydraulic machines	P3-01~06 P6-01~06
Continue to run when the frequency reference is lost	Air condition	Improve the continuity of the running	The inverter can continue to run when the control system is in fault and the frequency reference lost. It is suitable for air condition equipment of intelligent buildings.	P4-05
Speed detection	Mass load as windmill, coiling equipment	The motor is restarted in the free run.	For the free run motor, it is unnecessary to detect the speed of the motor to restart it. The inverter automatically detects the speed of the motor and speed up when it keep up with that speed.	23-01~03
DC braking before run.	Loads that keep rotate when stop running, such as windmill or pumps	The motor is restarted in the free running.	The free running motor can be broken by DCLNJ before restart if the rotation direction is indefinite.	22-01~03
Inverter/commercial power source switch run	The load that can be moved after stop running such as windmills or pumps	Switch between inverter and commercial power source	It is unnecessary to stop the motor for switch between the inverter and commercial power source, or the heavy load can be started first by commercial power source and then change speed by the inverter.	T1-01~06
Energy save run mode	Shifting beds, precise working machines	Save energy, reduce vibrations	Run with full voltage at accelerating or decelerating; perform energy save mode run with fixed speed. It always used to reduce the vibrations in the work of precise machines.	28-01~02 T1-01~06
Multi-section speed run	Convey machines	Perform periodical run with multi-section preset speed.	Control eight-section speed run with simple point-pressing signal, simply control positions by cooperating with external sensitive switch.	41-01~08 T1-01~06
Overheat alarm for the inverter	Air conditioner	Safety maintenance	The added thermostat can transmit the overheat signal to inverter for necessary alarm and preventive measures if the inverter is in danger because of the over-high circumjacent temperature.	T1-01~06
Any speed arrival signal output	Common occasion	Provide run status signal	When the inverter works at any output frequency range, this signal is put out to the external system or control circuitry	P4-01~04 T2-01~03
Output frequency arrival 1	Common occasion	Provide run status signal	When the output frequency is above any fixed value, this signal is put out to external system or control circuitry.	P4-01~04 T2-01~03
Output frequency arrival 1	Common occasion	Provide run status signal	When the output frequency is above any fixed value, this signal is put out to external system or control circuitry.	P4-01~04 T2-01~03
Base block status	Common occasion	Provide run status	This signal is put out to external system or control circuitry when the inverter performs BASE BLOCK	T2-01~03
Protection to overheated brake resistor	Common occasion	Safety maintenance	The signal that represents the brake resistor is over heated or the brake resistor's transistor fault can be put out if protected brake resistor is installed in the inverter.	P8-01
Detection of the frequency reference urgent change	Common occasion	Improve the continuity and reliability of run	The inverter put out this signal to external system or control circuitry when the frequency urgently reduces to below 10% of the original set value.	T2-01~03 P4-05
Analog input *	Common occasion	Improve the operability	The interface card can be added to the inverter, which using high resolution analog frequency reference. The external negative or positive voltage signals can directly control the inverter's forward or reverse run.	-
Analog output *	Common occasion	Show the run status	Interface card can be added to the inverter to use frequency reference, voltage, DC voltage and other signals with high resolution. After adding to interface card, frequency meter, voltage meter, and current meter can be installed to display the relative information.	-
Digital input *	Common occasion	Improve the operability.	The interface card can be added to the inverter to use digital meta-frequency reference. (BCD 2 Bit/BIN 8 Bit) (BCD 4 Bit/ BIN 16 Bit)	-

Function Name	Applying Occasion	Purpose	Function Description	Relative Parameters
Pulse output	Common occasion	Display the run status	The output frequency of the inverter is put out with the pulse mode on the interface card.	-
Digital output	Common occasion	Provide run status	The fault of the inverter output by six sets of optical couple and two sets of relays	-
2Cconnection point output card*	Common occasion	Provide run status	Two sets of C connection points provide run status of the inverter to clients for control.	-
Multifunction analog input	Common occasion	Improve the operability	The external analog signal can adjust the auxiliary frequency reference for the inverter, the input voltage and current.	T3-04~07
Multifunction analog output	Common occasion	Display the run status	The auxiliary frequency for the inverter, output current, output voltage or DC voltage can be displayed by added frequency meter or current meter.	T4-01~06
Elapsed time	Common occasion	Display the run time.	The elapsed time of the inverter can be used to calculate work efficiency.	02-07~08
Detection of phase-absence of input/output power source	Common occasion	Safety maintenance	It is a self-protection function of the inverter, if the phase-absence occurs at the inverter or motor side, the necessary warning and protective measures can be given.	P8-05~07
PID control function	Air conditioner	Improve the operability	The PID function keeps the output stable through preset value and feedback value.	25-01~08
RS-232C 485communication	Common occasion	Improve the operability	It can use interface card to communicate with PLC or MOK-BUS, realizing 1 to 32 controls.	T5-01~04

5. Run Test

5.1 Check before Run

- (A) Power source
 - If the wiring of the main loop is correct?
 - If the screws of the terminals have been turned tightly?
 - If there are short circuits caused by mis-wiring or broken power source?
 - If the loads are in normal status?
- (B) Selection of Power Source Voltage:
 - The power source should set as 220V if the input voltage of the inverter is 220V grade, and 440 V for the 440V grade. The voltage value should be correctly input in parameter 51-01.

5.2 Commissioning Test: Please verify if the voltage grade and connection of the power source are correct before the power source is brought into use.
Please cut down the power immediately if fault sound, smoke or off odor occur when it is brought into use.

5.3 Selection of Run Methods:

The inverter has two run methods: PANEL and FWD. The original leaving factory setting is FWD mode (the terminal references of control loop are available).

The parameters are described as follows:

PANEL: The frequency and run reference mainly depend on operation. The FWD led is off.

FWD: The frequency and running reference mainly depend on external terminals. The FWD led is on.

Parameter	Display of the operator	Options of frequency references	FWD LED	FWD LED
21-01	REFERENCE SOURCE	0: The frequency references mainly depend on the setting by operator (41-01) 1: The frequency references depend on the setting by external terminal FIV and FIC. 2: The frequency references mainly depend on setting by communication transmission. 3: The frequency references mainly depend on setting by interface card.	OFF ON FLASH FLASH	
21-02	RUN SOURCE	0: The run references mainly depend on setting by operator. 1: The run references mainly depend on setting by external terminals. 2: The run references mainly depend on setting by communication transmission. 3: The run references mainly depend on setting by interface card.		OFF ON FLASH FLASH

5.4 Setting before Run:

- Please perform test run without load of motor to avoid damage of machines caused by misacts. Please pay attention to the safety of machines and operators when performing inevitable loading run test.

Operation Check Points:

Please verify the correctness of the followings:

- If the motor runs smoothly.
- If the rotation direction of the motor is correct.
- If the motor abnormally vibrates.
- If the motor runs smoothly in accelerating or decelerating.
- If the load current is under the rated value.
- If the led of operator number is normal.

* Performing test run with digital openrator or external terminal signal:

The operation time sequence is as follows:

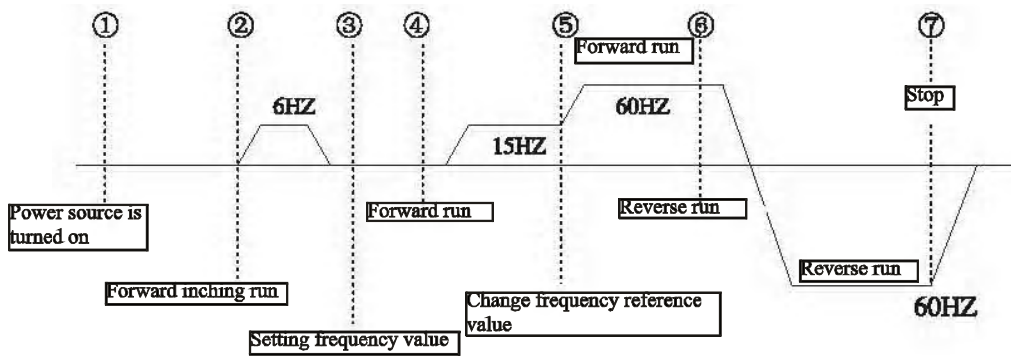

6. Setting Control Method

6.1 Features of Control Methods

Control Method	V/F control Not PG	V/F control PG	Vector Control Not PG	Vector Control PG
Basic Control	V/F Control	V/F W/PG FDBK	Open Loop Vector	FLUX VECROR
Speed detector	Unnecessary	Necessary (PG)	Unnecessary	Necessary (PG)
Speed detection	Unnecessary	PG-B2	Unnecessary	PG-B2
Speed Control Range	1:40	1:40	1:100	1:1000
Start torque				
The precision of speed control				
Torque control	Unavailable	Unavailable	Unavailable	Available
Low noise correspondence	Standard correspondence	Standard correspondence	Standard correspondence	Standard correspondence
Application	1: Diving several motor at the same time. 2: The parameters of the motor remains unknown. 3: It is unavailable EASY-TUNING	PG is attached at the machine side.	The occasions need changing speed.	1: Simple servo drive. 2: High precision servo control 3: Torque control.

6.2 Selecting Control Method

Four control methods are provided:

- 0. V/F control
- 1. V/F W/PG FDBK
- 2. OPEN LOOP VECTOR
- 3. FLUX VECTOR

The users can select the control methods through digital operator according to their demands. The inverter has been set as OPEN LOOP VECTOR before leaving factory. Please set control method and parameters of the motor according to the following procedure.

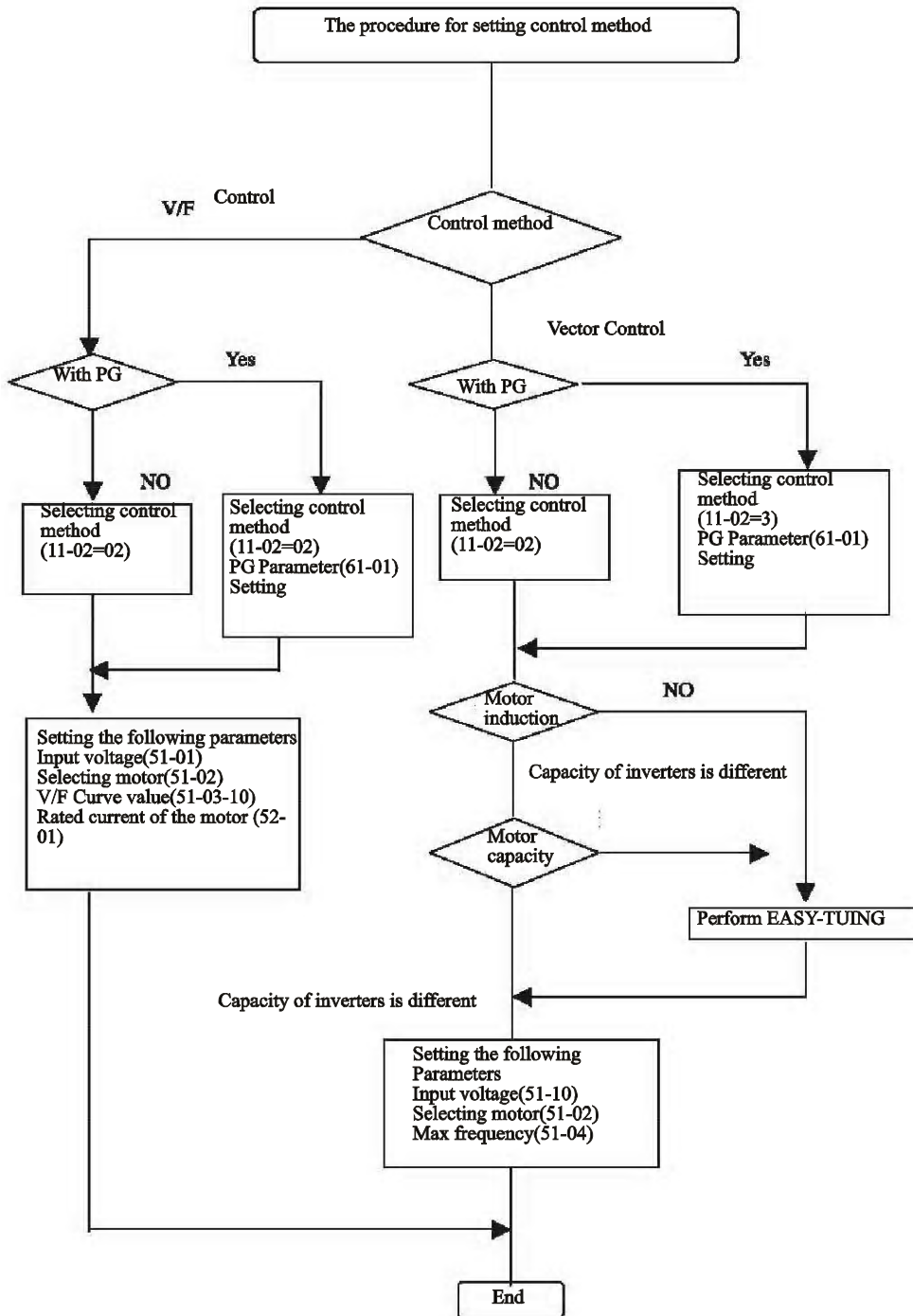

6.3 Display and Operation Control Functions of the Digital Operator

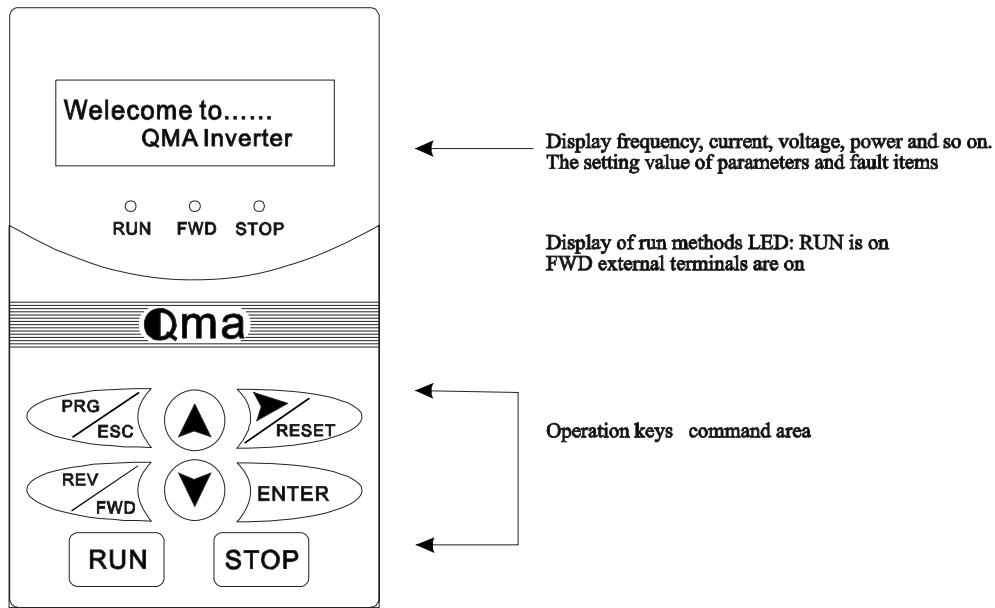

RUN, STOP: Run methods display: RUN is on or STOP is on.

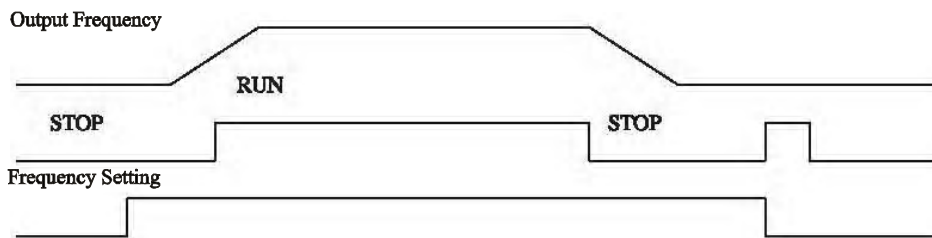

RUN	OFF	ON	FLASH	OFF	ON
STOP	ON	OFF	ON	ON	FLASH











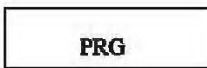
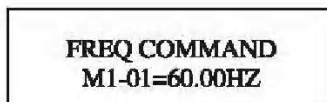
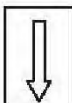

6.4 Description of Keys of the Digital Operator:

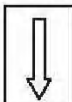
Key	Descr	ption	Function
PRG/ESC	PRG=Programming method ESC=Return to the previous screen		(1)PRG: Press one time to enter PRG method, press down 2 seconds to return *MAIN MENU* screen. (2)ESC: pres one time to return the previous screen.
RESET	RESET=Reset		Press this key
↑	UP (increase)		Select the name of parameters or modify the set value. UP (Increase)
↓	Down (decrease)		Select the name of parameters or modify the set value. DOWN (Decrease)

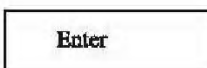
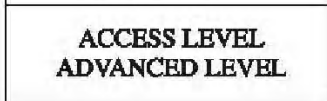
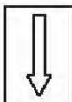
	Move right	Modify the set value
REV/FWD	REV/FWD (Reverse / Forward run)	REV: Reverse run FWD: Forward run
ENTER	ENTER (Type in information or return to RUN screen).	Enter: The set value of the information is sent to the memory and return to the RUN screen.
RUN	RUN (Run)	Run: start up running on the operator. RUN led is on.
STOP	STOP (Stop)	Stop: Stop the running on the operator. STOP led is off.

6.5 Changing Control Methods:

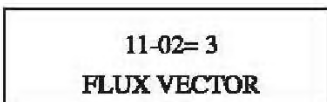
The following operation describes the change procedure from OPEN LOOP VECTOR control method to the FLUX VECTOR control method.

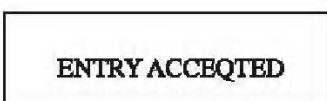
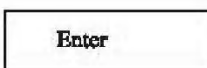
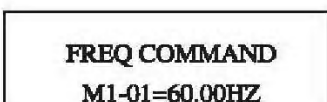
Description	Key Sequence	Display on the Operator
Frequency reference display		
Press down [PRG] for 2 seconds to return to "MAIN MENU"		
Press down [UP/DOWN KEY] until the INIT-SET screen appears, and then press ENTER KEY	 	
Press UP/DOWN KEY		
Display CONTROL METHOD screen, and then press ENTER KEY	 	
Change the control method Press down UP/DOWN KEY until the FLUX VECTOR screen appears.		
Press ENTER KEY Select the FLUX VECTOR	 	
Return to RUN method Press down [PRG] for 2 seconds to return to *Qma MENU*		
Display frequency reference		
		

6.6 EASY-TUNING Procedure

Notice	
1.	In EASY-TUNING, the motor runs automatically. Please part the motor from machine for the sake of safety.
2.	In EASY-TUNING, the input signal of control loop terminals is unavailable.
3.	In EASY-TUNING, because the frequency of carrier wave changes to 2KHZ, 5KHZ, there will be obvious electromagnetic noise during the motor is running.
4.	The access level of environmental setting parameters (11-01) should be set as BASIC or ADVANCED, and then perform EASY-TUNING.
5.	Before EASY-TUNING, please first verify that the motor is not running, and then press RUN key.

[Operation Procedure]

	Procedure	Method and Operation																
1	Verifying the security	<ul style="list-style-type: none"> • If the motor was parted from the machine ? • If there are people or other articles near the shift of the motor? • If the mechanical brake was released (motor attached with mechanical brake)? • If the shift of the motor was taken off? 																
2	Connect the inverter to the power source	<ul style="list-style-type: none"> • Verify there is no fault status occurs. • Verify the rotation direction of PG (when PG is attached). 																
3	Select methods of tuning	<ul style="list-style-type: none"> • Parameter error is not verified in run, or in heavy fault. • Selecting control methods (Set value before leaving factory : FLUXVECTOR). 11-02 (2): OPENLOOP VECTOR (3): FLUCVECTOR • Press <input type="button" value="PRG"/> key, select <input type="button" value="*MAIN MENU* (RUN/STATUS)"/> • Press <input type="button" value="↑"/> or <input type="button" value="↑"/> key, select <input type="button" value="*MAINMENU* (EASY-TUING)"/> 																
4	Type in the information on the motor's nameplate	<ul style="list-style-type: none"> • Press <input type="button" value="ENTER"/> key to type in the information of the motor (Value on the nameplate of the motor) <table border="1" style="width: 100%; border-collapse: collapse;"> <thead> <tr> <th style="width: 50%;">Name of Information</th> <th style="width: 50%;">Value</th> </tr> </thead> <tbody> <tr> <td>RATED VOLTAGE [VAC]</td> <td>Rated voltage of the Motor [VAC]</td> </tr> <tr> <td>RATED CURRENT [A]</td> <td>Rated current of the motor [A]</td> </tr> <tr> <td>RATED FREQUENCY [HZ]</td> <td>Motor rated frequency [HZ]</td> </tr> <tr> <td>RATED SPEED [RPM]</td> <td>Rated speed [RPM] (Motor with fixed torque)</td> </tr> <tr> <td>NUMBER OF POLES</td> <td>Number of poles of the motor</td> </tr> <tr> <td>SELECT MOTOR 1/2</td> <td>Select motor</td> </tr> <tr> <td>PG PULSES/REV [RPM]</td> <td>Number of pulse wave of PG[RPM]</td> </tr> </tbody> </table>	Name of Information	Value	RATED VOLTAGE [VAC]	Rated voltage of the Motor [VAC]	RATED CURRENT [A]	Rated current of the motor [A]	RATED FREQUENCY [HZ]	Motor rated frequency [HZ]	RATED SPEED [RPM]	Rated speed [RPM] (Motor with fixed torque)	NUMBER OF POLES	Number of poles of the motor	SELECT MOTOR 1/2	Select motor	PG PULSES/REV [RPM]	Number of pulse wave of PG[RPM]
Name of Information	Value																	
RATED VOLTAGE [VAC]	Rated voltage of the Motor [VAC]																	
RATED CURRENT [A]	Rated current of the motor [A]																	
RATED FREQUENCY [HZ]	Motor rated frequency [HZ]																	
RATED SPEED [RPM]	Rated speed [RPM] (Motor with fixed torque)																	
NUMBER OF POLES	Number of poles of the motor																	
SELECT MOTOR 1/2	Select motor																	
PG PULSES/REV [RPM]	Number of pulse wave of PG[RPM]																	

	Procedure	Method and Operation
		<p>(1): Press ENTER key, display INVERTER MODEL# <input type="text"/> <input type="text"/> V <input type="text"/> <input type="text"/> HP/<input type="text"/> <input type="text"/> KW RATED VOLTAGE <input type="text"/> <input type="text"/> • VAC</p> <p>(2): Press ↑ ↓ or → key to modify the set information, and then press ENTER key.</p> <p>(3): Press → key, display RATED CURRENT <input type="text"/> <input type="text"/> • <input type="text"/> A</p> <p>(4): Repeat step (2).</p> <p>(5): RATED FREQUENCY <input type="text"/> <input type="text"/> • <input type="text"/> HZ → RATED SPEE <input type="text"/> <input type="text"/> <input type="text"/> RPM → NUMBER OF POLES <input type="text"/> <input type="text"/> → SELECT MOTOR 1/2 <input type="checkbox"/></p> <p>* PG PULSES/RE <input type="text"/> <input type="text"/> PPR * This screen will not appear under FLUX VECTOR.</p> <p>(6): Press ↑, display PROCESSTUNNING? PRESS RUN KEY</p>
5	Perform TUNING	<ul style="list-style-type: none"> The rotation direction of the motor is indicated by FWD LED or REV LED. Press FWD/REV key to change the rotation direction and then press RUN key if necessary. In TUNING TUNE PROCEEDING <input type="text"/> <input type="text"/> HZ <input type="text"/> <input type="text"/> • <input type="text"/> A When the TUNING is completed, the message TUNE SUCCESSFUL appears. If press STOP key in TUNING, the EASY-TUNING will break and the motor will freely stop.
6	After TUNING	<ul style="list-style-type: none"> When the TUNING has been completed or broken, press PRG to return RUN screen. Repeat step (1)-(5) to perform EASY-TUNING again.

6.7 The Fault Display When Performing EASY-TUNING and the Countermeasure

When the following fault is detected, the digital operator displays fault and the motor is freely stop.

Fault Display	Fault Content	Description	Countermeasure
!DATA ERROR!	Motor information fault	Input of motor information for TUNING is not correct.	<ul style="list-style-type: none"> • Verify the input information. • Verify the capacity of the inverter and the motor.
RESISTANCE	Interline resistance is fault	TUNING is not completed in the given time	<ul style="list-style-type: none"> • Verify the input information. • Verify the wires of the motor.
NO-LOAD CURRENT	No-load current fault		
SATURATION-1	Core saturation 1 fault		
SATURATION-2	Core saturation 2 fault		
ACCELERATE	Rated speed drop fault.		
RATED SLIP	Accelerating fault.	The motor has not accelerated in the given time.	<ul style="list-style-type: none"> • ncrease the acceleration time (31-01). • Separate the motor from the machine if they are linked.
PG DIRECTION	The reverse direction of the motor fault.	PG of the inverter (A phase, B phase) is not correctly connected with the motor (U, V, W).	<ul style="list-style-type: none"> • Verify PG wiring • Verify wires of the motor.
MOTOR SPEED	Motor speed is fault.	The torque reference is excessive large (100%) when TUNING.	<ul style="list-style-type: none"> • Separate motor from machine if they are linked. • Increase the acceleration time (31-01). • Verify the input information, especially the number of PG pulse wave.
ALARM: OVERLOAD	The load is too heavy.	The torque reference exceeds 20% when TUNING.	<ul style="list-style-type: none"> • Verify the input information, especially the number of PG pulse wave.

7. Detailed Description on Parameter Groups

7.1 1 Parameter Group

Parameter No.	Name	Set value before leaving factory	Description	Remark
11-00	Factory ID		Q-7000-EL	
11-01	Access level of parameters	4	0: Operation only 1: User program 2: Quick start setting 3: Base level setting 4: Advanced level setting	
11-02	Selection of control method	2	0: V/F Control 1: V/F W/PG FDBK control 2: Open Loop Vector control 3: Flux Vector control	
11-03	Reset primary value	0000	1110=User self-reset 2220=2-wire reset 3330=3-wire reset	
11-04	Password 1	0000	Type in password 1	
11-05	Password 2	0000	Type in password 2	(>key+PRG key)
12-01 ~ 12-32	User's parameters		If 11-01=1, 12-01~32, user set the needed parameters of access No. by himself	If 11-01=1, user select OPERATION ONLY

7.2 2 Parameter Group

Parameter No.	Name	Set value before leaving factory	Description	Rem	ark										
21-01	Selection of frequency reference	1	<table border="1"> <thead> <tr> <th>Set Value</th> <th>Description</th> </tr> </thead> <tbody> <tr> <td>0</td> <td>Run reference from digital operator</td> </tr> <tr> <td>1</td> <td>Run reference from control terminals</td> </tr> <tr> <td>2</td> <td>Run reference from serial communication</td> </tr> <tr> <td>3</td> <td>Run reference from OPTION card</td> </tr> </tbody> </table>	Set Value	Description	0	Run reference from digital operator	1	Run reference from control terminals	2	Run reference from serial communication	3	Run reference from OPTION card		If 21-01=1, the frequency reference is FIV+FIC. (If the terminal FIC is set as multifunction input, the frequency reference is terminal FIV).
Set Value	Description														
0	Run reference from digital operator														
1	Run reference from control terminals														
2	Run reference from serial communication														
3	Run reference from OPTION card														
21-02	Selection of run reference	1													
21-03	Selection of stop method	0	<p>• When operation stop, FWD show the run method PANEL: Frequency and run references from digital operator FWD references are determined by parameter 21-01 and 21-02</p> <p>(0) 21-03=00, decelerated stop (1)21-03=01 free stop</p> <p>Zero speed level (22-01)</p> <p>Stop DCLNJ time (22-04)</p> <p>(2) 21-03=02 All field DCLNJ</p> <p>Output frequency</p> <p>DCLNJ time (22-04)</p> <p>10%speed 100%speed</p> <p>The output frequency when the reference input stop.</p>		If 1-03=3, only 00 or 01 can be set.										

Parameter No.	Name	Set value before leaving factory	Description	Re	mark										
			<p>(3) 21-03=03 free stop (Attaching timing function)</p> <p>The output frequency when the reference input stops After the reference input stop, the reference is ignored within T1, then, if there is no run reference input, it will not run.</p>												
21-04	Selection of reverse forbidding	0	<table border="1"> <thead> <tr> <th>Set Value</th> <th>Description</th> </tr> </thead> <tbody> <tr> <td>0</td> <td>Reverse run is available</td> </tr> <tr> <td>1</td> <td>Reverse run is forbidden</td> </tr> </tbody> </table>	Set Value	Description	0	Reverse run is available	1	Reverse run is forbidden						
Set Value	Description														
0	Reverse run is available														
1	Reverse run is forbidden														
21-05	Selection of run below the min frequency	0	<table border="1"> <thead> <tr> <th>Set value</th> <th>Description</th> </tr> </thead> <tbody> <tr> <td>0</td> <td>Common run (51-09 is unavailable)</td> </tr> <tr> <td>1</td> <td>Base Block (B.B)</td> </tr> <tr> <td>2</td> <td>Run with the min frequency</td> </tr> <tr> <td>3</td> <td>Zero speed run</td> </tr> </tbody> </table>	Set value	Description	0	Common run (51-09 is unavailable)	1	Base Block (B.B)	2	Run with the min frequency	3	Zero speed run		<ul style="list-style-type: none"> If 51-09=0, this function is unavailable. If 11-02=0, 1, 2, it performs B.B run below the min frequency.
Set value	Description														
0	Common run (51-09 is unavailable)														
1	Base Block (B.B)														
2	Run with the min frequency														
3	Zero speed run														

Parameter No.	Name	Set value before leaving factory	Description	Rem	ark						
			<p>Run reference</p> <p>OFF</p> <p>ON analog input frequency reference</p> <p>frequency reference 51-09</p> <p>0</p> <p>21-05=0 Inner frequency reference Run referenc ON Spced 22-01 perform BB</p> <p>0 Initial excitation idem content</p> <p>21-05=1 BB idem content BB</p> <p>21-05=2 Initial excitation idem content 21-05=0 BB</p> <p>21-05=3 BB idem content BB</p>								
21-06	Control terminal scanning second time selection	1	<table border="1"> <thead> <tr> <th>Set Value</th> <th>Description</th> </tr> </thead> <tbody> <tr> <td>0</td> <td>2msec</td> </tr> <tr> <td>1</td> <td>5msec</td> </tr> </tbody> </table>	Set Value	Description	0	2msec	1	5msec		
Set Value	Description										
0	2msec										
1	5msec										
21-07	After PANEL/ FWD Run	0	<table border="1"> <thead> <tr> <th>Set Value</th> <th>Description</th> </tr> </thead> <tbody> <tr> <td>0</td> <td>From PANEL to FWD, if FWD run reference is sent, it will not run.</td> </tr> <tr> <td>1</td> <td>From PANEL to FWD, if FWD run reference is sent, it will run immediatcly.</td> </tr> </tbody> </table>	Set Value	Description	0	From PANEL to FWD, if FWD run reference is sent, it will not run.	1	From PANEL to FWD, if FWD run reference is sent, it will run immediatcly.	<p>If the set value is 0, the STOP LED will flash once the run reference is OFF.</p>	
Set Value	Description										
0	From PANEL to FWD, if FWD run reference is sent, it will not run.										
1	From PANEL to FWD, if FWD run reference is sent, it will run immediatcly.										

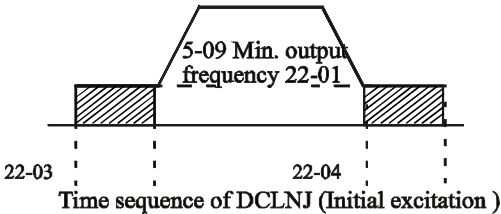
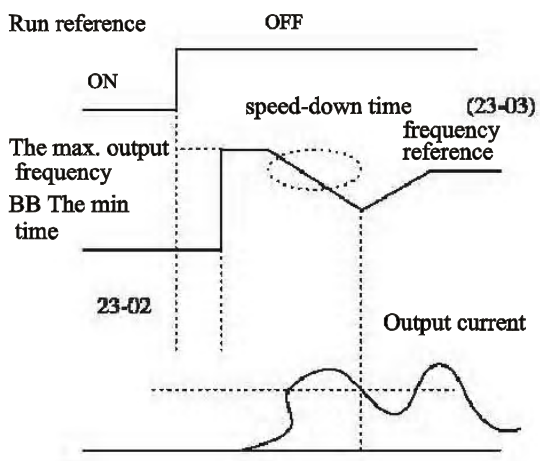
Parameter No.	Name	Set value before leaving factory	Description	Re	mark						
22-01	Zero speed level (the frequency at which the DCLNJ starts).	0.5	In decelerated stop, the starting frequency is set with 0.1 Hz step size. If 22-01<51-09, taking 51-09 as the starting value of DCLNJ.								
22-02	Current of DCLNJ	50	The unit of setting current of DCLNJ is 1%, the rated current of the inverter is 100%. *If 11-02=3, set current value according to 52-03 to perform initial excitation.								
22-03	DCLNJ time at start	0.00	If the rotation direction of the motor is indefinite, start the DCLNJ to avoid the restarting of the motor in free run to jump.		If the set value is 0, the DCLNJ is not performed at start.						
22-04	DCLNJ time at stop.	0.05	Prevent motor sliding when stop. 		If set value is 0, the DCLNJ is not performed when stop.						
23-01	Selection of speed search at start	0	<table border="1"> <thead> <tr> <th>Set Value</th> <th>Description</th> </tr> </thead> <tbody> <tr> <td>0</td> <td>Accelerate from the min. output frequency to the set speed</td> </tr> <tr> <td>1</td> <td>When start: (1) with PG, search accelerating or decelerating according to the speed of the motor. (2) Without PG, set the max output frequency to search for.</td> </tr> </tbody> </table>	Set Value	Description	0	Accelerate from the min. output frequency to the set speed	1	When start: (1) with PG, search accelerating or decelerating according to the speed of the motor. (2) Without PG, set the max output frequency to search for.		With PG, 23-01 the Set value before leaving factory is set as 01.
Set Value	Description										
0	Accelerate from the min. output frequency to the set speed										
1	When start: (1) with PG, search accelerating or decelerating according to the speed of the motor. (2) Without PG, set the max output frequency to search for.										
23-02	Speed search level	100	The unit setting speed search level is 1%. The rated current of the inverter is 100%.								
23-03	Speed detection time in speed search	2.0	<p>The unit setting speed-down time is 0.1 second, in speed search act.</p>  <p>V/F control without PG Speed search when start</p>								

Parameter No.	Name	Set value before leaving factory	Description	Rem	ark												
24-01	TIMER Function ON DELAY Time	0.0	After the setting of Time input (set value=18) of the multifunction input terminals of inner of the inverter and the time output (set value =12) of the multifunction terminals, it will be OK.														
24-02	TIMER function OFF DELAY time	0.0	<p>Act Description:</p> <p>(6)TIMER output connection point will not act if the “ON” time of the TIMER input connection point is shorter than 24-01.</p> <p>(7)TIMER output connection point will become “ON” if the “ON” time of the TIMER input connection point is shorter than 24-01.</p> <p>(8)TIMER output connection point will remain “ON” if the “OFF” time of the TIMER input connection point is shorter than 24-02.</p> <p>(9)TIMER output connection point will become “OFF” if the “OFF” time of the TIMER input connection point is shorter than 24-02.</p>		Please refer to T1-01 ~ T1-06												
25-01	PID control method selection	0.0	<table border="1"> <tr> <td>25-1</td> <td>PID control function</td> </tr> <tr> <td>0</td> <td>PID control is available (Deflection value D control)</td> </tr> <tr> <td>1</td> <td>PID control is available (feedback value D control)</td> </tr> <tr> <td>2</td> <td>PID available (frequency output+PID+ deflection value D control)</td> </tr> <tr> <td>3</td> <td>PID available (frequency output+PID+ feedback value D control)</td> </tr> <tr> <td>4</td> <td>PID available (frequency output+PID+ feedback value D control)</td> </tr> </table> <p>• When performing PID control, please set MFI multifunction analog input (T3-05) as 0B.</p> <p>• The setting of the target value is selected by frequency reference signal selection parameter (21-01). If (21-01=0), can take parameter speed reference 1-3 (T1-03, T1-04, T1-05) or inching reference signal (T1-06) as target value. If (21-01=1), the target value can be put in by terminal FIV or FIC as analog signal.</p>	25-1	PID control function	0	PID control is available (Deflection value D control)	1	PID control is available (feedback value D control)	2	PID available (frequency output+PID+ deflection value D control)	3	PID available (frequency output+PID+ feedback value D control)	4	PID available (frequency output+PID+ feedback value D control)		
25-1	PID control function																
0	PID control is available (Deflection value D control)																
1	PID control is available (feedback value D control)																
2	PID available (frequency output+PID+ deflection value D control)																
3	PID available (frequency output+PID+ feedback value D control)																
4	PID available (frequency output+PID+ feedback value D control)																

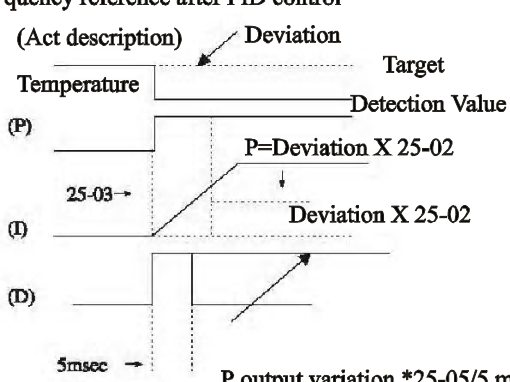
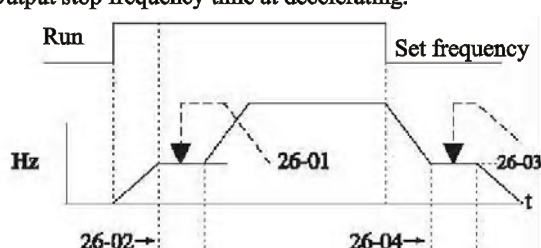
Parameter No.	Name	Set value before leaving factory	Description	Re	mark
25-02	Proportional Gain (P)	1.00	The proportional gain value under the P control.		
25-03	Integral Time	1.0	Integral time value under the control of I		
25-04	Integration Limit	100.0	The rate of max frequency 51-04 is 100%.		
25-05	Derivative Time	0.00	Derivative time under the control of D		
25-06	PID Limit	100.0	PID limit, the rate of the max frequency (51-01) is corresponding to the control limit value.		
25-07	PID deviation adjustment.	0.0	Setting of the output deviation value after PID control, the percentage of deviation value is corresponding to the max of 51-04.		
25-08	PID first delay time	0.00	<p>First delay time constant is corresponding to the frequency reference after PID control</p> <p>(Act description)</p>  <p>The value of I will be reset as 0 in the following status:</p> <ol style="list-style-type: none"> (1) Stop input of reference or in stop status. (2) The multifunction terminal is set as <i>Cancel PID Control</i>, and the input terminal is "OFF". (3) In running, if the multifunction terminal is set as <i>Cancel PID Control</i>, the target value signal will be taken as frequency reference signal. <p>The DWELL refers to the function that the motor makes pause during accelerating for starting up or decelerating for when the motor drives heavy load or during decelerating to against jump.</p>		
26-01	DWELL frequency at start.	0.0	Output stop frequency at accelerating		
26-02	DWELL time at start	0.0	Output stop frequency time at start		
26-03	DWELL frequency at stop	0.0	Output stop frequency time at decelerating.		
26-04	DWELL time when stop	0.0	<p>Output stop frequency time at decelerating.</p> 		

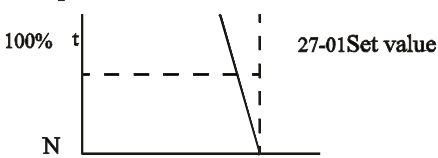
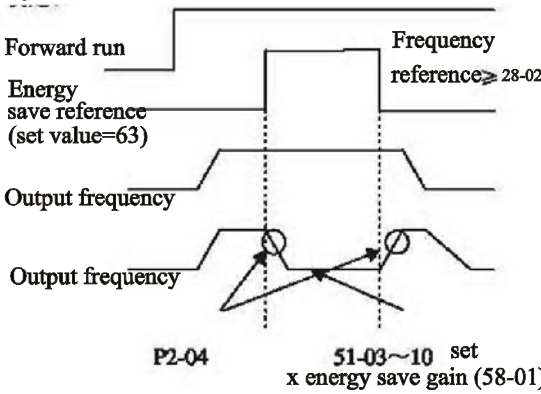
Parameter No.	Name	Set value before leaving factory	Description	Rem	ark
27-01	DROOP Control Gain	0.0	DROOP control provides a function that decreasing speed corresponding to load change. 27-01 is rated torque 100% to correspond the decrease rate of the max rotation speed (51-04). Decrease the set value of 27-02, and the response of DROOP will be faster, but it may lead to the pursuit of the motor.		This function is only available when 11-02=3 (Vector Control with PG).
27-02	DROOP Delay Time	0.05	 <p>To the load that the current will decrease after accelerating, the energy save run method can be realized through decreasing the output voltage.</p>		
28-01	Energy save Gain	80	If the multifunction terminal is set as "energy save" reference input, the output voltage start to decrease when the frequency reaches energy save frequency (28-02).		
28-02	Start frequency of energy save	0.0	<p>The output voltage of energy save run is equal to Normal V/F setting (51-03~10) × Energy save gain (28-01). The time of voltage decrease and recovery is set according to P2-04.</p>  <p>Zero servo function is the position control performed when the motor speed is lower than the zero speed of the inverter.</p>		This function is available if 11-02=0, 1.
29-01	Zero servo gain	5	The set value of zero servo gain		
29-02	The width of zero servo	10	The PULSE of the PG is a unit setting the width of zero servo.		<p>*Please refer to the function selection of multifunction input terminal T1-01-T2-06</p> <p>*Please refer to the function selection of multifunction T1-01-T2-03, use it when 11-02=3 (FLUX VECTOR control).</p>

Parameter No.	Name	Set value before leaving factory	Description	Re	mark

7.33 Parameter Group

Parameter No.	Name	Set value before leaving factory	Description	Remark			
31-01	Accelerating time 1	10.0	Accelerating time refers to the time from 0Hz to the max frequency.				
31-02	Decelerating time 1	10.0	Decelerating time refers to the time from the max frequency to 0Hz.				
31-03	Accelerating Time 2	10.0	With multifunction input set accelerating and decelerating reference 1, 2, you can get four-stage change of accelerating and decelerating time.				
31-04	Decelerating time 2	10.0	(1)Set accelerating and decelerating time 1 (Set value of multifunction terminal=07).				
31-05	Accelerating Time 3	10.0	(2)Set accelerating and decelerating time 2 (Set value of multifunction terminal =1A)				
31-06	Decelerating time 3	10.0					
31-07	Accelerating Time 4	10.0					
31-08	Decelerating Time 4	10.0	Accelerating and decelerating time 2 T1-01~06=1A		Accelerating and decelerating time 1 T1-01~06=07	Accelerating time	Decelerating time
			OFF or not set		OFF or not set	31-01	31-02
			OFF or not set		OFF	31-03	31-04
			OFF	OFF or not set	31-05	31-06	
			OFF	OFF	31-07	31-08	
31-09	Time of urgent stop	10.0	The time of urgent stop is available in the following status: • Set multifunction terminal as time of urgent stop (set value=15) input. • Set it as urgent stop if fault is detected.				
31-10	The unit setting accel/ decel time	1	Set Value Set Value	Description			
			0	The unit of accel/decel time (31-01-09) is 0. second. The set range is 0~6000.0 seconds.			
			1	The unit of accel/decel time (31-01~09) is 0.01 second. The set range is 0~600.0 seconds.			

Parameter No.	Name	Set value before leaving factory	Description	Remark						
31-11	Accel/decel time switch frequency	0.0	<ul style="list-style-type: none"> According to the set value of 31-11, the accel/decel time can be switched automatically. The inner of the inverter 31-01~31-09 automatically change set unit when 31-01 changes; 31-10 will not change to 1 if the change of 31-01~31-09 exceeds 600.1. If the output frequency \geq 31-11, it will run with accel/decel time 31-01, 02. If the output frequency $<$ 31-11, it will run with accel/decel time 31-07, 08. <ul style="list-style-type: none"> If the multifunction terminal is set as accel/decel reference input, the priority is superior to accel/decel time start switch function. 							
32-01	S curve characteristic time when starting accelerating	0.20	<ul style="list-style-type: none"> S curve characteristic can prevent machines from librations when start or stop. The following starting accelerating, completing accelerating, starting decelerating, completing decelerating can be divided into four independent S characteristic that can be set respectively. 	<p>The accelerating time from 0 to the max frequency is accelerating time $+\frac{(32-01)+(32-01)}{2}$</p>						
32-01	S curve characteristic time when accelerating is complete.	0.20								
32-03	S curve characteristic time when starting decelerating	0.20								
32-04	S curve characteristic time when decelerating is complete.	0.00								
33-01	Slip compensation gain	1.0	<p>Slip compensation gain is various according to different control methods.</p> <ul style="list-style-type: none"> In V/F and OPEN LOOP VECTOR control, it should calculate motor torque according to output current and set gain to compensate output frequency, the setting unit is 0.1. <p>The precision will decrease when the load is running and you can adjust 33-01.</p> <table border="1" style="width: 100%;"> <tr> <td>Run status</td> <td>adjusting 33-01</td> </tr> <tr> <td>Slower than the real speed</td> <td>Increase the set value</td> </tr> <tr> <td>Faster than the real speed</td> <td>Decrease the set value</td> </tr> </table> <ul style="list-style-type: none"> Please change vector control 33-01 slowly, increasing or decreasing 0.1 every time. Adjust gain value to compensate slip caused by the temperature change. It is usually unnecessary to change the set. 	Run status	adjusting 33-01	Slower than the real speed	Increase the set value	Faster than the real speed	Decrease the set value	
Run status	adjusting 33-01									
Slower than the real speed	Increase the set value									
Faster than the real speed	Decrease the set value									

Parameter No.	Name	Set value before leaving factory	Description	Remark						
33-02	Slip compensation first delay time	200	<p>It is used to regulate if the speed is not stable or the speed response is slow when the load is running under V/F or OPEN LOOP VECTOR control.</p> <table border="1"> <tr> <td>Run Status</td> <td>Adjustment of 33-02</td> </tr> <tr> <td>Slower than the real speed</td> <td>Increase the set value</td> </tr> <tr> <td>Faster than the real speed</td> <td>Decrease the set value</td> </tr> </table> <p>* The adjusting unit is 10 ms.</p>	Run Status	Adjustment of 33-02	Slower than the real speed	Increase the set value	Faster than the real speed	Decrease the set value	
Run Status	Adjustment of 33-02									
Slower than the real speed	Increase the set value									
Faster than the real speed	Decrease the set value									
33-03	Limit of slip compensation	200	<p>Limit of slip compensation is corresponding to set rate 52-02 (%), the rated slip of the motor.</p> <p>The limit of fixed torque and fixed horse power is as follows: 51-04/51-06*33-03</p>							
33-04	Selection of slip compensation in regeneration.	0	<table border="1"> <tr> <td>Set value</td> <td>slip compensation</td> </tr> <tr> <td>0</td> <td>No</td> </tr> <tr> <td>1</td> <td>Yes</td> </tr> </table>	Set value	slip compensation	0	No	1	Yes	
Set value	slip compensation									
0	No									
1	Yes									
33-05	Selection of magnetic beam characteristic	0	<table border="1"> <tr> <td>Set value</td> <td>Description</td> </tr> <tr> <td>0</td> <td>Calculate according to the output frequency after slip compensation.</td> </tr> <tr> <td>1</td> <td>Calculate according to the output frequency before slip compensation.</td> </tr> </table>	Set value	Description	0	Calculate according to the output frequency after slip compensation.	1	Calculate according to the output frequency before slip compensation.	
Set value	Description									
0	Calculate according to the output frequency after slip compensation.									
1	Calculate according to the output frequency before slip compensation.									
34-01	Torque compensation	1.00	<ul style="list-style-type: none"> Calculate the torque value of the load according to the output current to compensate the output voltage to guarantee the torque that the load needed. The compensation gain is not necessary to adjust in FLUX VECTOR control. The adjustment in V/F control : <table border="1"> <tr> <td>Run status</td> <td>34-01</td> </tr> <tr> <td>The torque is not enough in underspeed run</td> <td>Increase the set value</td> </tr> <tr> <td>The motor current is not stable or is too large in light load run.</td> <td>Decrease the set value</td> </tr> </table> <p>*The following status may occur if increase the torque compensation gain:</p> <ul style="list-style-type: none"> The current through the motor is too large, which may lead to the fault of the inverter. The motor may heat or vibrate. <p>Please slowly adjust the set value and verify the motor current.</p>	Run status	34-01	The torque is not enough in underspeed run	Increase the set value	The motor current is not stable or is too large in light load run.	Decrease the set value	
Run status	34-01									
The torque is not enough in underspeed run	Increase the set value									
The motor current is not stable or is too large in light load run.	Decrease the set value									

Parameter No.	Name	Set value before leaving factory	Description	Remark						
34-02	Time constant of torque compensation	20	<ul style="list-style-type: none"> In the occasion that the motor output current is not stable or the speed response is slower. The time constant is not necessary to adjust in FLUX VECTOR control. <table border="1" style="margin-left: 20px;"> <tr> <td>Run status</td> <td>34-02</td> </tr> <tr> <td>Motor current</td> <td>Increase the set value</td> </tr> <tr> <td>Response speed</td> <td>Decrease the set value</td> </tr> </table> <p>* Adjust 10 ms every time.</p>	Run status	34-02	Motor current	Increase the set value	Response speed	Decrease the set value	
Run status	34-02									
Motor current	Increase the set value									
Response speed	Decrease the set value									
35-01	ASRproportional gain 1	20.00	The unit setting ASR proportional 1 is 0.01/							
35-02	ASR integral time 1	0.500	The unit setting ASR integral time 1 is 0.001 sec.							
35-03	ASRproportional gain 2	20.00	The unit setting ASR proportional gain 2 is 0.01.							
35-04	ASR integral time 2	0.500	The unit setting ASR integral time 2 is 0.001sec.							
35-05	ASR limit	5.0	It is complementary frequency limit of ASR in V/F W/ PG FDBK control. (Note) The max frequency output value is set based on the max frequency (51-04), 1% as the unit. In V/F W/PG FDBK control, the P (gain value) of ASR.							
35-06	ASR output delay time	0.004	It is the time constant of primary delay time that limit the change of the secondary current reference in FLUX VECTOR control. The setting unit is 0.001 sec.							
35-07	ASR switch frequency	0.0	In FLUX VECTOR control, the proportion of ASR with gain, the integral time constant, switch frequency, the setting unit is 0.1Hz.							
35-08	ASR integral limit	400	<p>The setting unit is 1%.</p> <p>[ASR block diagram of FLUX VECTOR control]</p> <p>(The relation between the proportional gain and integral time approximate line and motor is as follows):</p> <p>$P=35-01, I=35-02$ $35-07=0$ 时, $P=35-01, I=35-02$</p> <p>$P=35-01, I=35-02$ $f_{FB} = \frac{PN}{120}, P = \text{Number of poles}, N = \text{r/min}$</p> <p>(The multfunction input terminal is set as 77, the proportional gain may change):</p> <p>P gain according to the motor speed in the above graph P gain according to set value 35-03.</p> <ul style="list-style-type: none"> The change of time is set by 35-02 The integral time doesn't change. 							

Parameter No.	Name	Set value before leaving factory	Description	Remark						
			<p>(ASR block diagram of V/F W/PG FDBK control):</p> <p>Frequency reference → Output frequency</p> <p>Speed detected value → Limit of change rate → P → I → ASR limit (+ 35-05) → Output frequency</p> <p>35-01, 03</p> <p>35-02, 04</p> <p>Graph: P vs Motor speed (f_{FB}). P=35-01, I=35-02. P=35-03, I=35-04. $f_{FB} = \frac{PN}{120}$, P= Number of Poles, N=r/min</p>							
36-01	The upper limit of carrier wave frequency	15	<p>The graph below shows the relation of carrier wave frequency (36-01~06) and output frequency.</p> <p>Only 36-01 is available in vector control. When using a certain carrier wave frequency (36-01 set value), please set 36-03 as 0.</p> <p>Set the same value to 36-01 and 36-02.</p> <p>36-01</p> <p>36-02</p> <p>Output frequency</p> <p>Output frequency*36-03*K</p> <p>[Value of K varies according to the difference of upper limits of carrier wave.]</p> <table border="1"> <tr> <td>$36-01 \geq 10.0\text{kHz}$</td> <td>K=3</td> </tr> <tr> <td>$10.0\text{kHz} > 36-01 \geq 5.0\text{kHz}$</td> <td>K=2</td> </tr> <tr> <td>$36-01 < 5.0\text{kHz}$</td> <td>K=1</td> </tr> </table> <p>The inverter will display the error information OPE11 1.36-03>6, 36-02>36-01 2.36-01>5kHz, 36-02<5kHz</p>	$36-01 \geq 10.0\text{kHz}$	K=3	$10.0\text{kHz} > 36-01 \geq 5.0\text{kHz}$	K=2	$36-01 < 5.0\text{kHz}$	K=1	
$36-01 \geq 10.0\text{kHz}$	K=3									
$10.0\text{kHz} > 36-01 \geq 5.0\text{kHz}$	K=2									
$36-01 < 5.0\text{kHz}$	K=1									
36-02	The lower limit of carrier wave frequency	15								
36-03	The proportional gain of carrier wave frequency	00								
37-01	Pursuit prevention function selection	1	<p>When the light load runs with 10~30Hz, the motor current amplitude will change or the machine will vibrates, which is called pursuit phenomenon.</p> <p>In V/F control, the pursuit prevention function should be set as available.</p> <table border="1"> <thead> <tr> <th>Set value</th> <th>Discretion</th> </tr> </thead> <tbody> <tr> <td>0</td> <td>Pursuit prevention function is unavailable.</td> </tr> <tr> <td>1</td> <td>Pursuit prevention function is available.</td> </tr> </tbody> </table>	Set value	Discretion	0	Pursuit prevention function is unavailable.	1	Pursuit prevention function is available.	
Set value	Discretion									
0	Pursuit prevention function is unavailable.									
1	Pursuit prevention function is available.									

Parameter No.	Name	Set value before leaving factory	Description	Remark	
37-02	Pursuit prevention gain	1.00	The unit setting pursuit prevention gain is 0.01.		
			Run status	37-02	
			Pursuit when the load is light	Increase	
			Mechanical librations or Pursuit when the load is heavy	Decrease	
38-08	AFR gain	1.00	OPEN LOOP VECTOR control, the adjustment when the motor vibrates or the response is so fast or slow.		
38-09	AFR constant	50	Run status	38-08Adjustment	38-09Adjustment
			The torque speed responses too slow .	Increase	Increase
			librations	Decrease	Decrease
* Adjust 0.05 every time.					

7.4 Parameter Group

Parameter No.	Name	Set value before leaving factory	Description	Remark																				
41-01	Frequency reference 1	0.00	<table border="1"> <thead> <tr> <th>Terminal (Parameter No.)</th> <th>Set value before leaving factory</th> <th>Set value</th> <th>Name</th> </tr> </thead> <tbody> <tr> <td>MS1(T1-03)</td> <td>3</td> <td>3</td> <td>Multi-section speed reference</td> </tr> <tr> <td>MS2(T1-04)</td> <td>4</td> <td>4</td> <td>Multi-section speed reference</td> </tr> <tr> <td>JOB(T1-05)</td> <td>6</td> <td>5</td> <td>Multi-section speed reference</td> </tr> <tr> <td>BB(T1-06)</td> <td>8</td> <td>6</td> <td>Inching reference</td> </tr> </tbody> </table>		Terminal (Parameter No.)	Set value before leaving factory	Set value	Name	MS1(T1-03)	3	3	Multi-section speed reference	MS2(T1-04)	4	4	Multi-section speed reference	JOB(T1-05)	6	5	Multi-section speed reference	BB(T1-06)	8	6	Inching reference
Terminal (Parameter No.)	Set value before leaving factory	Set value			Name																			
MS1(T1-03)	3	3			Multi-section speed reference																			
MS2(T1-04)	4	4			Multi-section speed reference																			
JOB(T1-05)	6	5			Multi-section speed reference																			
BB(T1-06)	8	6			Inching reference																			
41-02	Frequency reference 2	0.00																						
41-03	Frequency reference 3	0.00																						
41-04	Frequency reference 4	0.00																						
41-05	Frequency reference 5	0.00																						
41-06	Frequency reference 6	0.00																						
41-07	Frequency reference 7	0.00																						
41-08	Frequency reference 8	0.00																						
41-09	Inching reference	6.00	<ul style="list-style-type: none"> • If T1-01=0, the main speed frequency is set by 41-01. • If T1-01=1, the main speed frequency is set by terminal FIV or FIC through inputting analog signal • If T3-05=00, the auxiliary frequency is set by terminal MFI through inputting analog signal. • If T3-0500, the auxiliary frequency is set by 41-02, if the multifunction terminal MFI is not used, it should be set as IF (T3-05=1F). 																					

Parameter No.	Name	Set value before leaving factory	Description	Remark						
42-01	The upper limit of frequency reference	100	<ul style="list-style-type: none"> Take 1% as the unit of the upper and lower limit. 100% is corresponding to the max frequency (51-04). If the frequency is 0, when the run reference is input, the motor will accelerate from the min frequency to the lower limit of the frequency reference and go on run at this frequency. 							
42-02	Lower limit of frequency reference	0.0								
43-01	Jump frequency 1	0.0		The following sequence should be followed when setting :43-01—01: 43-0343-0243-01						
43-02	Jump frequency 2	0.0								
43-03	Jump frequency 3	0.0								
43-04	The width of jump frequency	1.0								
44-01	Selection of frequency reference holding	0	<p>It is the selection whether hold memory the frequency in HOLD status when using multifunction terminal UP/DOWN or the accel/decel stop reference in HOLD status, the power source is OFF or stop reference is input.</p> <table border="1"> <thead> <tr> <th>Set value</th> <th>Discretion</th> </tr> </thead> <tbody> <tr> <td>0</td> <td>Do not hold frequency reference in HOLD</td> </tr> <tr> <td>1</td> <td>Do not hold the frequency reference in HOLD, the motor will run again with the held output frequency.</td> </tr> </tbody> </table>	Set value	Discretion	0	Do not hold frequency reference in HOLD	1	Do not hold the frequency reference in HOLD, the motor will run again with the held output frequency.	
Set value	Discretion									
0	Do not hold frequency reference in HOLD									
1	Do not hold the frequency reference in HOLD, the motor will run again with the held output frequency.									
44-04	+ - speed limit	25								
45-04	Selection of torque control	0	<table border="1"> <thead> <tr> <th>Set value</th> <th>Discretion</th> </tr> </thead> <tbody> <tr> <td>0</td> <td>speed control</td> </tr> <tr> <td>1</td> <td>Torque control</td> </tr> </tbody> </table>	Set value	Discretion	0	speed control	1	Torque control	This function is available only if 11-02=3.
Set value	Discretion									
0	speed control									
1	Torque control									
45-02	Torque reference delay time	0	In torque control method, the primary delay time of input torque reference is set with the unit of 1ms.							
45-03	Selection of the speed limit	1	<p>The speed limit value of torque control method</p> <table border="1"> <thead> <tr> <th>Set value</th> <th>Discretion</th> </tr> </thead> <tbody> <tr> <td>0</td> <td>The speed limit value is set by control terminal 13 or 14</td> </tr> <tr> <td>1</td> <td>The speed limit value is set by parameter (45-04).</td> </tr> </tbody> </table>	Set value	Discretion	0	The speed limit value is set by control terminal 13 or 14	1	The speed limit value is set by parameter (45-04).	
Set value	Discretion									
0	The speed limit value is set by control terminal 13 or 14									
1	The speed limit value is set by parameter (45-04).									
45-04	Speed limit	0	If 45-03=2, the speed limit of torque control method takes the max frequency (51-04) as 100%.							

Parameter No.	Name	Set value before leaving factory	Description	Remark
45-05	Speed limit bias	10	In torque control method, the speed limit bias takes the max frequency (51-04) as 100%.	
45-06	The speed/torque control method switch time	0	Speed/torque control terminal input, the real control method switch time is set with the unit of 1ms.	Function terminal setting (set value: 71).

• If 11-02=3, the torque control can be performed.
 In torque control, set 45-0 as 1, or set multifunction terminal as "speed/torque control" (input terminal Close), set MFI as "Torque reference" (T3-05=13).

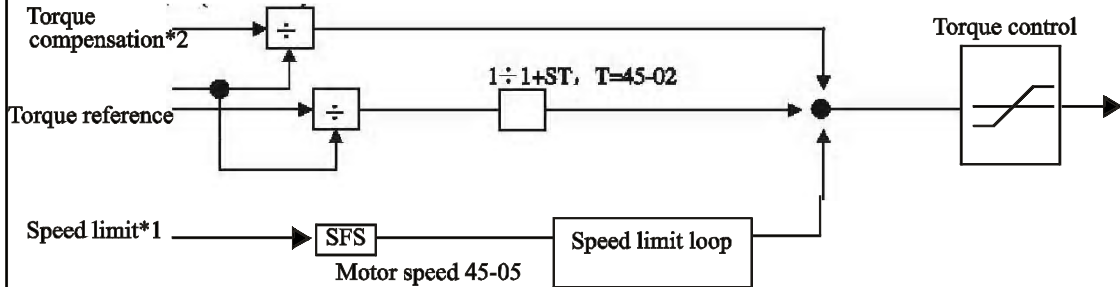

*1: If speed limit (45-03)=1, main frequency reference is input through terminal FIV, FIC, speed limit is input through terminal FIC, please set T3-09=1F; If 45-03=2, the speed limit value is set by parameter 45-04.

*2: If the function of terminal FIC is set as "torque compensation" (T3-09=14), the value input by terminal FIC1 is the torque compensation value.

Component	Winder Act		Spool-out machine act	
	Direction			
Rotation direction	Forward run	Reverse run	Forward run	Reverse run
torque refer-ence	+	-	-	+
Speed limit	+	-	+	-
Torque				

Discretion

Torque control act: The polarity of speed limit with torque is according to the speed limit selected in 45-03 (speed limit control selection); the input polarity is decided by the forward/reverse run reference of run reference.

	Speed limit input polarity	
Run reference	+	-
Forward run	+	-
Reverse run	-	+

[Act Description]

If torque reference >0, speed limit >0 (winder acts), the following acts will be performed:

- If $-1 \times \text{speed limit bias (45-05)} < \text{motor speed} < \text{"Speed limit +45-05"}$, perform the torque control according to the set torque reference .
- If $\text{motor speed} > \text{"Speed limit +45-05"}$, the speed limit loop put out negative torque reference to prevent the raising of motor speed.
- If $\text{motor speed} < \text{"-1} \times 45-05\text{"}$, speed limit loop put out torque reference to prevent motor speed from raising .

Thus, if torque reference >0, speed limit >0, the possible torque control range $\text{"-1} \times 45-05\text{"} < \text{motor speed} < \text{"speed limit +45-05"}$, when 11-02=3, multifunction input terminal is set as 71, the speed/torque control switch can be performed in running, as shown in the following fig.

Terminal NO.	Paramete NO.	leaving factory	Set value	Description
BX	T106	BX	71	Speed /torque control switch
FIV	21-01	FWD	1	Frequency reference selection(Terminal FIV,FIC)
	45-03	FWD	1	Speed limit selection (Terminal FIV, FIC)
MFI	T3-05	FWD	13	Torque reference /Torque limit

[Act Description]:

- If the torque /speed control switch reference is "OFF"
 - In speed control, speed reference is decided according to the set of 21-01.
 - In speed control, the benchmark of torque limit value is the one with smaller absolute value between the torque limit value of terminal MFI and the set value P7-01~04.
 - Input stop reference in speed control, the speed control still remain, the min absolute value of terminal 16, then torque limit and parameter set value P7-01~04 absolute value
- If the Torque/speed control switch reference is "ON"
 - In torque control, if 45-02=1, the speed limit value is input by terminal FIV or FIC; if 45-03=2, the speed limit value is set by parameter 45-04.
 - In torque control, the analog signal input by terminal MFI is regarded as torque reference.
- In torque control, it automatically switch to speed control method and the motor decelerated stop when stop reference is input. The torque limit in decelerated stop is set by P7-01~04.

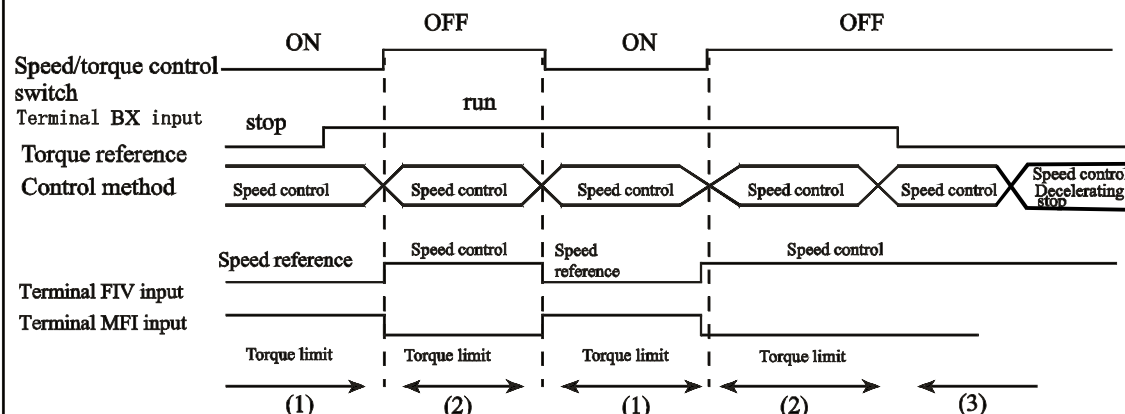

7.5 5 Parameter Group

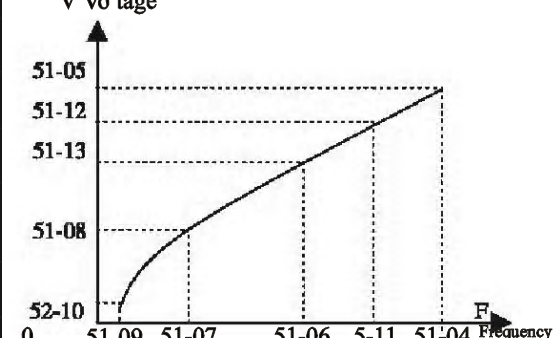
Parameter No.	Name	Set value before leaving factory	Description	Remark						
51-01	Input voltage setting	200	The unit setting input voltage is 1V.							
51-02	Motor selection	0	Set motor protective characteristics: <table border="1" style="width: 100%;"> <thead> <tr> <th>Set value</th> <th>Description</th> </tr> </thead> <tbody> <tr> <td>0</td> <td>Standard motor protective characteristics</td> </tr> <tr> <td>1</td> <td>FC motor protective characteristic</td> </tr> </tbody> </table>	Set value	Description	0	Standard motor protective characteristics	1	FC motor protective characteristic	
Set value	Description									
0	Standard motor protective characteristics									
1	FC motor protective characteristic									
51-03	V/F curve selection	F	V/F curve selection in V/F control method <table border="1" style="width: 100%;"> <thead> <tr> <th>Set value</th> <th>Description</th> </tr> </thead> <tbody> <tr> <td>0-E</td> <td>Fixed curve</td> </tr> <tr> <td>F</td> <td>Any V/F curve</td> </tr> </tbody> </table> <ul style="list-style-type: none"> The set value is fixed as F in vector control. 	Set value	Description	0-E	Fixed curve	F	Any V/F curve	Please refer to 7.51 V/F control method [Fixed curve "0-E"] parameter.
Set value	Description									
0-E	Fixed curve									
F	Any V/F curve									
51-04	The max output frequency	60.0	<p>If 51-03=F, V/F curve can be set by 51-04~13</p>  <p>The following sequence should be followed in setting frequency: $51-09 \leq 51-06 \leq 51-11 \leq 51-04$. (Note) Increase V in V/F curve, and the motor torque will be increased too, but if V is adjusted too large, the following status will occur: <ul style="list-style-type: none"> The current passing through the motor will be too large, which may lead to inverter fault. The motor may heat or vibrate. Please increase V value and verify the motor current.</p>	If 51-13 is set as 0, the base voltage=the max current.						
51-05	The max voltage	200.0								
51-06	Base voltage	60.0								
51-07	Middle output frequency	3.0								
51-08	Middle output frequency voltage	11.0								
51-09	The min output frequency	0.5								
51-10	The min output frequency voltage	2.0								
51-11	Middle output frequency	0.0								
51-12	Middle output frequency voltage	0.0								
51-13	Base voltage	0.0								
52-01	Rated current of the motor	1.9			The unit setting motor rated current is 0.01A when the rated current is 7.5 KW or below, and 0.1A when 11KW and above.					
52-02	Rated slip of the motor	2.9			The unit setting rated slip is 0.01 Hz, the reduction formula of (PRM) (Hz): $F_s = (\text{Rated slip Hz}) - (\text{Rated rotate speed rpm}) / 120$					
52-03	No-load current of the motor	1.20			The unit setting motor's rated current is 0.01A when the no-load current is 7.5 KW or below, and 0.1 A when 11KW and above.					
52-04	Number of the poles of the motor	4	Set according to the number of the poles of the motor.							
52-05	Interline impedance	9.842	The unit setting interline impedance is 0.001o.							
52-06	Leak inductance of the motor	18.2	The unit setting leak inductance of the motor is 0.1%.							
52-07	Core saturation coefficient of the motor 1	0.5	It is the setting of core saturation coefficient of the motor at 50% magnetic beam. (It is set automatically in EASY-TUNING).							
52-08	Core saturation coefficient of the motor 2	0.75	It is the setting of core saturation coefficient of the motor at 75% magnetic beam. (It is set automatically in EASY-TUNING).							
52-09	Mechanical loss of the motor	0.0	The unit setting mechanical loss of the motor is 0.1%. The rated output of the motor is 100%.							

7.51 V/F Control Method [Fixed Curve 0-E]

V/F curve setting: 51-03="0"~"E", there are 15 kinds of V/F curves which can be chose according to motor type, load, operation status. You should take account of the following matters in selecting the curve: (1) *Voltage-frequency characteristic of the motor*; (2) *the max frequency of the motor*.

2.2-45 KW (2HP-60 HP) V/F Parameter application Description

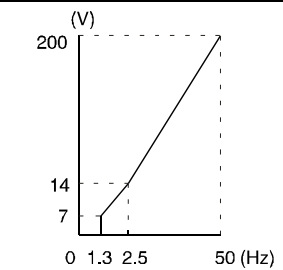
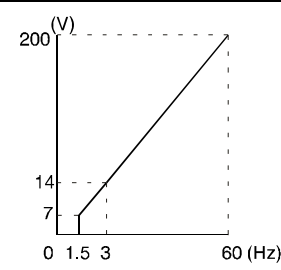
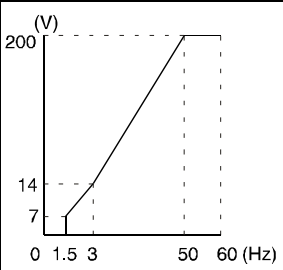
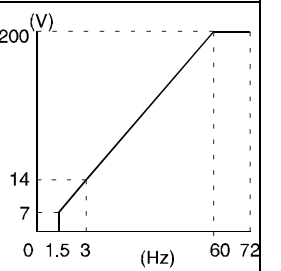
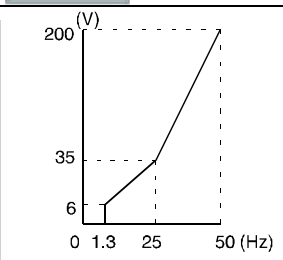
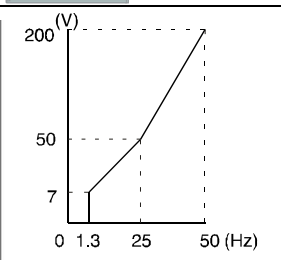
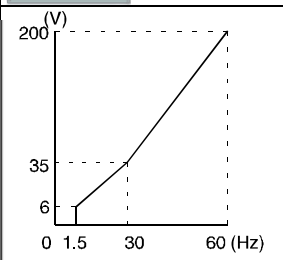
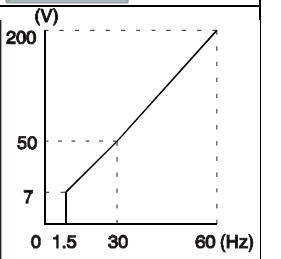
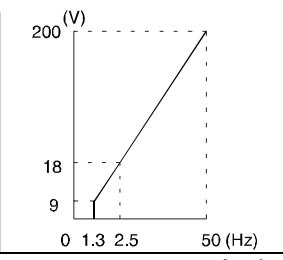
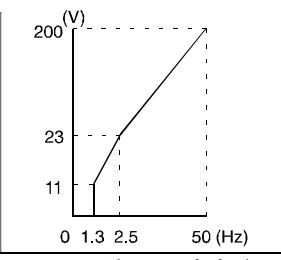
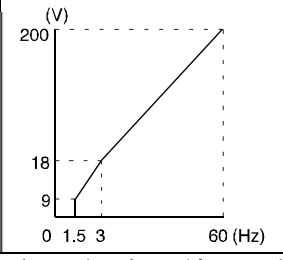
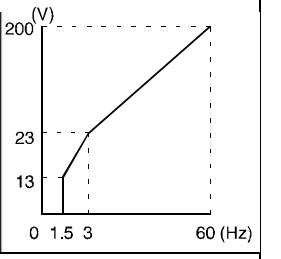
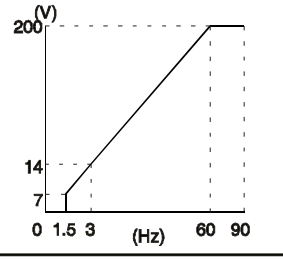
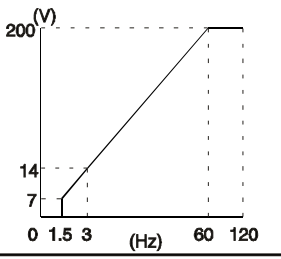
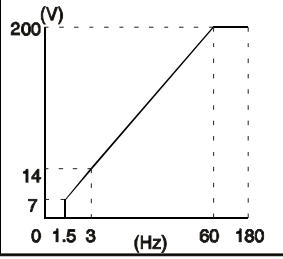
Fixed Torque Characteristics (Set value0~3) *Common Use*			
Set value 0 (50HZ)	Set value 1 (60HZ)	Set value 2 (60HZ)	Set value 3 (72HZ)
			
Degressive Torque Characteristics (Set value4~7) * Wind Power Machines and Hydraulic Machines*			
Set value 4 (50HZ)	Set value 5 (50HZ)	Set value 6 (60HZ)	Set value 7 (50HZ)
			
High start Torque Characteristics (Set value8~B)			
Set value 8 (50HZ)	Set value 9 (50HZ)	Set value A (60HZ)	Set value B (60HZ)
			
Fixed Output Run Characteristic (Set value0~3) * Working Machines*			
Set value C (90HZ)	Set value D (120HZ)	Set value E (180HZ)	
			

* The curves above mentioned are suitable for 220 V grade, the voltage value X2 for 400V grade.

* 110 KW (100HP)~300KW (400HP) curves are only for 400 V grade.

V/F Curve Setting: 51-03=0~E

55-300KW (75HP~400HP) V/F Parameter Application Description

Fixed Torque Characteristics(Set value0~3)			
Set value 0 (50HZ)	Set value 1 (60HZ)	Set value 2 (60HZ)	Set value 3 (72HZ)
Degressive Torque Characteristics (Set value4~7) * Wind Power Machines and Hydraulic Machines*			
Set value 4 (50HZ)	Set value5 (50HZ)	Set value 6 (60HZ)	Set value 7 (50HZ)
High start Torque Characteristics(Set value8~B)			
Set value 8 (50HZ)	Set value 9 (50HZ)	Set value A (60HZ)	Set value B (60HZ)
Fixed Output Run Characteristic(Set value0~3) * Working Machines*			
Set value C (90HZ)	Set value D (120HZ)	Set value E (180HZ)	

* The curves above mentioned are suitable for 220 V grade, the voltage value ×2 for 400V grade.

* 110 KW (100HP)~300KW (400HP) curves are only for 400 V grade.

7.6 6 Parameter Group

Parameter No.	Name	Set value before leaving factory	Description	Remark
61-01	PG Constant	600	Number of pulse the coder generates in a revolution. [pulse/rev].	
61-02	Act selection when PG disconnection is detected.	1	The stop method setting when the PG is disconnected: 0: Decelerated stop(Decelerating time : 31-02) 1: Free stop 2: Urgent stop (Decelerating time: 31-09) 3: Continue to run (only show the disconnection, it can't be set if 11-02=3).	
61-03	Act selection when the over-speed is detected.	1	The stop method setting when the over-speed is detected: 0: Decelerated stop (Decelerating time : 31-02) 1: Free stop 2: Urgent stop (Decelerating time: 31-09). 3: Continue to run (only show the over-speed, it can't be set if 11-02=3).	
61-04	Act selection when the excessive deviation is detected	3	If the speed deviation is too large, the stop method setting: 0: Decelerated stop (Decelerating time : 31-02) 1: Free stop 2: Urgent stop (Decelerating time: 31-09). 3: Continue to run (only show excessive deviation).	
61-05	PG Tuning Direction	0	The relation between the tuning direction of the motor and the polarity of PG: 0: A phase is 90 degree ahead of B phase, when the motor is forward run. 1: B phase is 90degree ahead of A phase when the motor is forward running..	This reference is available when PG-B2 card is being used.
61-06	PG signal canceling rate (only available with PG card).	1	Set canceling rate of the pulse from PG to monitor. [Set signal canceling rate] PG signal removal =N+1/M (set range 1/1~1/32) N: 0,1 P: 1~32	This canceling rate has no matter with control, it is only used to monitor the feedback signal of PG-B2.
61-07	Integral control selection in accelerating or decelerating	0	If the integral act is performed in speed control loop (ASR) in accel/decel 0: Integral act is unavailable. 1: Integral act is available	
61-08	Over-speed detection level	115	The motor over-speed detection level takes 51-04(the max frequency) as 100%.	
61-09	Over-speed detection time	0.0	The setting of the time from the over-speed is detected to the fault signal act. The fault signal is put out and the motor stop if the absolute value of the motor speed exceeds the set value of 61-08, the time of over-speed exceeds the set value of 61-09.	The stop method of over-speed detection time is set as 61-03.
61-10	The excessive speed deviation detection level	10	The excessive speed deviation detection level takes 51-04 (the max frequency) as 100%. (it doesn't detect in accelerating/ decelerating or torque control).	The stop method of excessive speed deviation detection time is set as 61-04.
61-11	The detection time of excessive speed deviation	0.5	The setting of time from the excessive speed deviation is detected to the fault signal act. The fault signal put out and the monitor stops if the deviation of speed reference and the motor's speed exceeds the set value of 61-10 and the deviation time exceeds the set value of 61-11.	It doesn't detect during accelerating and decelerating or in torque control.
61-12	Reduction gear of PG 1	0	The revolution of the motor [r/min]=[the number of PG output pulse ×60/PG constant (61-01)]×[number of reduction teeth 2 (61-13)/number of reduction teeth 1(61- 12)]	It is unavailable if 61-12=0 and 61-13=0
61-13	Reduction gear of PG 2	0		
61-14	The delay time of PG disconnection	2.0	The setting of fault is detected after PG disconnection.	

7.7 T Parameter Group

Parameter No.	Name	Set value before leaving factory	Description				Remark	
	Function selection of multifunction input terminal		Function selection of terminal EF-BX		V/F	V/F	Vec tor	Vec tor
			Set value	Function	Con tro	with PG	Con tro	with PG
T1-01	Function selection of terminal EF-CM	24	0	3wire control Forward/Reverse selection	○	○	○	○
			1	PANEL/FWD selection (ON: operator)	○	○	○	○
			2	Option/Inverter switch	○	○	○	○
T1-02	Function selection of terminal RST-CM	14	3	Multi-section speed reference1	○	○	○	○
			4	Multi-section speed reference2	○	○	○	○
			5	Multi-section speed reference3	○	○	○	○
			6	Inching selection	○	○	○	○
T1-03	Function selection of terminal MS1-CM	3	7	Accel/decel time selection	○	○	○	○
			8	External B.B(connection point a)	○	○	○	○
			9	External B.B (connection point b)	○	○	○	○
T1-04	Function selection of terminal MS2-CM	4	A	Accel /decel pause, stop reference	○	○	○	○
			B	The warning on the inverter overhead.(ON: OH2)	○	○	○	○
			C	Multifunction input available unavailable	○	○	○	○
T1-05	Function selection of terminal JOG-CM	6	D	V/F-PG speed control cancel (ON: Available)	×	○	×	×
			E	Speed control integral reset	×	○	×	○
			F	Not be used	○	○	○	○
T1-06	Function selection of terminal BX-CM	8	10	UP reference (setting together with DOWN reference).	-	-	-	-
			11	DOWN reference (Setting together with UP reference).	○	○	○	○
			12	FJOG reference (ON: Forward inching)	○	○	○	○
			13	RJOG reference (ON: Reverse inching reference).	○	○	○	○
			14	Fault reset (ON: Upper edge reset)	○	○	○	○
			15	Urgent stop (if connection a OFF, 31-09 decelerating)	○	○	○	○
			16	Electric motor switch reference (2 electrical motor selection)	○	○	○	○
			17	Urgent stop (if connection b OFF , 31-09 decelerating)	-	-	-	-
			18	Time ON Delay OFF Delay input	-	-	-	-
			19	PID control cancel (ON: PID control cancel).	○	○	○	○
			1A	Accel/decel time selection2	○	○	○	○
			1B	Parameter writing forbid (ON: writing permit)	○	○	○	○
			1C	+speed reference (ON: 44-02 accelerating)	○	○	○	○
			1D	+speed reference (ON: 44-02 decelerating).	○	○	○	○
			1E	Sample time of analog frequency (sample keeping)	○	○	○	○
			1F	*Terminal FIV/FIC selection (ON: FIC).	○	○	○	○
			20, 2F	External fault	○	○	○	○
			30, 31	30: PID integral reset 33: PID integral keeping	○	○	○	○
			60	DCLNJ reference (ON: DCLNJ reference).	○	○	○	○
			61	external speed search reference 1 the max output frequency	○	○	○	○
			62	External speed search reference 2 the max output frequency	○	○	○	○
			63	Energy saving run (ON: 28-01, 02 set)	○	○	×	×
			64	External speed search reference	○	○	×	×
			65	Instant decelerating run reference connection point a	○	○	○	○
			66	Instant decelerating run reference connection point b	○	○	○	○
			71	Speed/torque control (ON: torque control)	×	×	×	○
			72	Zero servo (ON: zero servo)	×	×	×	○
			77	Speed control (ASR) propo- rtional gain switch (35-03).	×	×	×	○

Set Value	Description																																																													
3	<ul style="list-style-type: none"> Multifunction speed frequency reference 1~3 and inching speed frequency reference: set [3]~[6]. 																																																													
4	<ul style="list-style-type: none"> Eight frequency references and inching reference can be used, at most 9 sections of frequency reference. 																																																													
5	<ul style="list-style-type: none"> Switch these frequency references, please set at the multifunction input terminal: multi-section speed reference 1-3 and inching reference choice. 																																																													
6	<table border="1"> <thead> <tr> <th>Terminal</th> <th>Parameter No.</th> <th>Set Value</th> <th>Description</th> </tr> </thead> <tbody> <tr> <td>MS1</td> <td>T1-03</td> <td>3</td> <td>Multi-section speed reference 1 (If auxiliary frequency reference is set in T3-05, main speed/ auxiliary speed can switch).</td> </tr> <tr> <td>MS2</td> <td>T1-04</td> <td>4</td> <td>Multifunction speed reference 2</td> </tr> <tr> <td>JOG</td> <td>T1-05</td> <td>5</td> <td>Multifunction speed reference 3</td> </tr> <tr> <td>BX</td> <td>T1-06</td> <td>6</td> <td>Inching speed reference</td> </tr> </tbody> </table>	Terminal	Parameter No.	Set Value	Description	MS1	T1-03	3	Multi-section speed reference 1 (If auxiliary frequency reference is set in T3-05, main speed/ auxiliary speed can switch).	MS2	T1-04	4	Multifunction speed reference 2	JOG	T1-05	5	Multifunction speed reference 3	BX	T1-06	6	Inching speed reference																																									
	Terminal	Parameter No.	Set Value	Description																																																										
	MS1	T1-03	3	Multi-section speed reference 1 (If auxiliary frequency reference is set in T3-05, main speed/ auxiliary speed can switch).																																																										
	MS2	T1-04	4	Multifunction speed reference 2																																																										
	JOG	T1-05	5	Multifunction speed reference 3																																																										
	BX	T1-06	6	Inching speed reference																																																										
	<ul style="list-style-type: none"> Multifunction speed reference Inching speed reference The selected speed frequency reference 																																																													
	<table border="1"> <thead> <tr> <th>Terminal MS1</th> <th>Terminal MS2</th> <th>Terminal JOG</th> <th>Terminal BX</th> <th></th> </tr> </thead> <tbody> <tr> <td>Multifunction speed reference 1</td> <td>Multifunction speed reference 2</td> <td>Multifunction speed reference 3</td> <td>Inching speed reference</td> <td>The selected speed frequency reference.</td> </tr> <tr> <td>[BCD]</td> <td>[BCD]</td> <td>[BCD]</td> <td>[BCD]</td> <td>Speed frequency reference 1 (41-01) main speed frequency</td> </tr> <tr> <td>OFF</td> <td>OFF</td> <td>OFF</td> <td>OFF</td> <td>Speed frequency reference 2 (41-02) auxiliary frequency</td> </tr> <tr> <td>ON</td> <td>OFF</td> <td>OFF</td> <td>OFF</td> <td>Speed frequency reference 3 (41-03)</td> </tr> <tr> <td>OFF</td> <td>ON</td> <td>OFF</td> <td>OFF</td> <td>Speed frequency reference 4 (41-04)</td> </tr> <tr> <td>ON</td> <td>ON</td> <td>OFF</td> <td>OFF</td> <td>Speed frequency reference 3 (41-05)</td> </tr> <tr> <td>OFF</td> <td>OFF</td> <td>ON</td> <td>OFF</td> <td>Speed frequency reference 6 (41-06)</td> </tr> <tr> <td>ON</td> <td>OFF</td> <td>ON</td> <td>OFF</td> <td>Speed frequency reference 7 (41-07)</td> </tr> <tr> <td>OFF</td> <td>ON</td> <td>ON</td> <td>OFF</td> <td>Speed frequency reference 8 (41-08)</td> </tr> <tr> <td>ON</td> <td>ON</td> <td>ON</td> <td>OFF</td> <td>Inching frequency reference (41-09)</td> </tr> <tr> <td>-</td> <td>-</td> <td>-</td> <td>-</td> <td>Inching frequency reference (41-09)</td> </tr> </tbody> </table>		Terminal MS1	Terminal MS2	Terminal JOG	Terminal BX		Multifunction speed reference 1	Multifunction speed reference 2	Multifunction speed reference 3	Inching speed reference	The selected speed frequency reference.	[BCD]	[BCD]	[BCD]	[BCD]	Speed frequency reference 1 (41-01) main speed frequency	OFF	OFF	OFF	OFF	Speed frequency reference 2 (41-02) auxiliary frequency	ON	OFF	OFF	OFF	Speed frequency reference 3 (41-03)	OFF	ON	OFF	OFF	Speed frequency reference 4 (41-04)	ON	ON	OFF	OFF	Speed frequency reference 3 (41-05)	OFF	OFF	ON	OFF	Speed frequency reference 6 (41-06)	ON	OFF	ON	OFF	Speed frequency reference 7 (41-07)	OFF	ON	ON	OFF	Speed frequency reference 8 (41-08)	ON	ON	ON	OFF	Inching frequency reference (41-09)	-	-	-	-	Inching frequency reference (41-09)
	Terminal MS1	Terminal MS2	Terminal JOG	Terminal BX																																																										
	Multifunction speed reference 1	Multifunction speed reference 2	Multifunction speed reference 3	Inching speed reference	The selected speed frequency reference.																																																									
	[BCD]	[BCD]	[BCD]	[BCD]	Speed frequency reference 1 (41-01) main speed frequency																																																									
	OFF	OFF	OFF	OFF	Speed frequency reference 2 (41-02) auxiliary frequency																																																									
	ON	OFF	OFF	OFF	Speed frequency reference 3 (41-03)																																																									
	OFF	ON	OFF	OFF	Speed frequency reference 4 (41-04)																																																									
ON	ON	OFF	OFF	Speed frequency reference 3 (41-05)																																																										
OFF	OFF	ON	OFF	Speed frequency reference 6 (41-06)																																																										
ON	OFF	ON	OFF	Speed frequency reference 7 (41-07)																																																										
OFF	ON	ON	OFF	Speed frequency reference 8 (41-08)																																																										
ON	ON	ON	OFF	Inching frequency reference (41-09)																																																										
-	-	-	-	Inching frequency reference (41-09)																																																										
<ul style="list-style-type: none"> In speed frequency reference 1, the main frequency is set by 41-01 (21-01=1). The main speed frequency is set by terminal FIV or terminal FIC through inputting analog signal (21-01=1). In speed frequency reference 2, auxiliary frequency is set by 41-02 (T3-05=1F). Auxiliary frequency is set by terminal MFI through inputting analog signal (T3-05-0). If the multifunction analog input terminal MFI is not used, it should be set as (T3-05=1F). 																																																														
7	<ul style="list-style-type: none"> Accel /decel time selection has four sets, please set them in multifunction input terminal. If the choices of accel/decel time is 1,2 , the selection ON/OFF is as follows: 																																																													
1A	<table border="1"> <thead> <tr> <th>Accel/Decel Time Selection 1</th> <th>Accel/Decel Time Selection 2</th> <th>Accelerating Time</th> <th>Decelerating Time</th> </tr> </thead> <tbody> <tr> <td>OFF Or not be set</td> <td>OFF Or not be set</td> <td>Accelerating Time1(31-01)</td> <td>Decelerating Time1(31-02)</td> </tr> <tr> <td>ON</td> <td>OFF Or not be set</td> <td>Accelerating Time2(31-03)</td> <td>Decelerating Time1(31-04)</td> </tr> <tr> <td>OFF Or not be set</td> <td>ON</td> <td>Accelerating Time3(31-05)</td> <td>Decelerating Time1(31-06)</td> </tr> <tr> <td>ON</td> <td>ON</td> <td>Accelerating Time4(31-07)</td> <td>Decelerating Time1(31-08)</td> </tr> </tbody> </table>	Accel/Decel Time Selection 1	Accel/Decel Time Selection 2	Accelerating Time	Decelerating Time	OFF Or not be set	OFF Or not be set	Accelerating Time1(31-01)	Decelerating Time1(31-02)	ON	OFF Or not be set	Accelerating Time2(31-03)	Decelerating Time1(31-04)	OFF Or not be set	ON	Accelerating Time3(31-05)	Decelerating Time1(31-06)	ON	ON	Accelerating Time4(31-07)	Decelerating Time1(31-08)																																									
	Accel/Decel Time Selection 1	Accel/Decel Time Selection 2	Accelerating Time	Decelerating Time																																																										
	OFF Or not be set	OFF Or not be set	Accelerating Time1(31-01)	Decelerating Time1(31-02)																																																										
	ON	OFF Or not be set	Accelerating Time2(31-03)	Decelerating Time1(31-04)																																																										
	OFF Or not be set	ON	Accelerating Time3(31-05)	Decelerating Time1(31-06)																																																										
ON	ON	Accelerating Time4(31-07)	Decelerating Time1(31-08)																																																											

Set Value	Description
0	<p>(Setting Example) T1-01=00 three-wire method T1-01~606 set, the set value of three-wire procedure control 00 terminal become Forward/Reverse run.</p> <p>Timing Sequence Diagram</p>
1	<ul style="list-style-type: none"> • PANEL/FWD Selection The run signal switch is only available in stop status. OFF: in FWD, it runs with the set value of 20-01. 21-02. ON: in PANEL, it runs with the frequency reference or run reference from the digital operator. <p>(Note) When setting PANEL/FWD functions by multifunction terminals, the PANEL/FWD keys on digital operator are unavailable.</p>
2	<ul style="list-style-type: none"> • Optional Card/Inverter Switch The switch is only available in stop status. OFF: The inverter runs according to the frequency reference and run signal from the control loop terminals or the digital operator in the inverter. ON: The inverter will run according to the frequency reference and run reference from the optional card.
8	<ul style="list-style-type: none"> • External BB If the terminal is "ON", BB act will be performed.
9	<ul style="list-style-type: none"> • External BB If the terminal is "OFF", BB act will be performed.

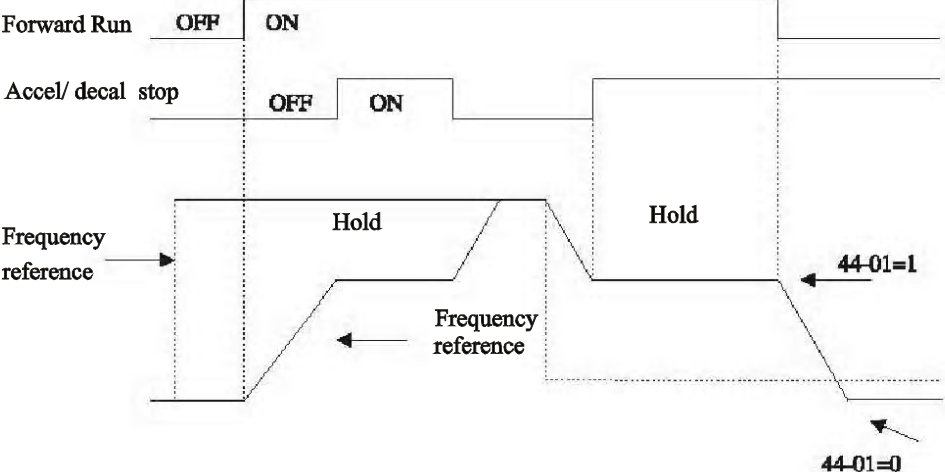
Set Value	Description
A	<p>• Accel/decel pause reference The accel /decel act will stop when the accel /decel pause command is input, the output frequency will keep constant. The accel/decel will be canceled with the canceling the run reference.</p>  <p>(Note) If 44-1=1, and accel/decel pause reference is input in running, after the input of this reference, the run reference is put again, the output frequency in the hold is kept, till this reference is cancel, the inverter will go on run with the output frequency in the hold. If 44-1=0, the output frequency in the hold will not be kept.</p>
B	<p>• The overhead alarm of inverter: the operator will show OH2 when the inverter overhead signal is input.</p>
C	<p>• Multifunction analog input is available/unavailable: (If it is "OFF", it is same function with T3-05=1F). (OFF: Multifunction analog input is unavailable) (ON: Multifunction analog input is available)</p>
D	<p>• Speed control cancel: (VF+PG Control speed with feedback, available /unavailable). OFF: Speed control is available (Close loop control) ON: Speed control is unavailable (Open close control).</p>
E	<p>• Speed control integral value reset: If 61-07 (accel/decel integral controller choice)=0, this function is available. Speed control integral reset is available even in run. OFF: PI control, the integral value of the speed control is added up. ON: P control, the integral value time constant has been reset.</p>
1C, 1D	<p>+speed reference, -speed reference Speed reference adds to / subtracts from 44-02 set value. (+ speed reference ON= frequency +41-02), (- speed reference ON=frequency reference -41-02) Note: 1.If the frequency reference is 41-01~09, +speed, _ speed is unavailable. 2.If +speed reference /-speed reference are set at the same time, (OPE3) fault will appear.</p>
1E	<p>Analog reference sample hold: 100 msce after OFF, the analog input is taken as frequency , sample/hold: Note: 1. The sample/hold of analog frequency, the analog input of the terminal FIV, FIC, MFI is correspondingly available. 2. Two or more of accel/decel stop (OA) UP/DOWN references (10.11)+speed reference , - speed reference 1C, 1D analog frequency reference, sample/hold (1E) are set at the same time, OPE03 will appear.</p>

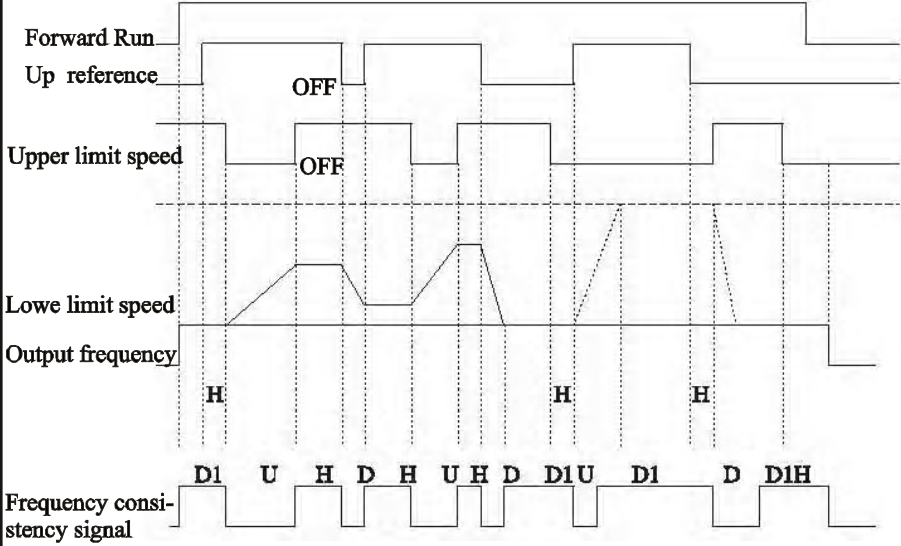
Set Value	Description															
10, 11	<p>• UP/DOWN reference Forward (Reverse) run reference is input, if you want to change frequency reference, you can use UP and DOWN signal reference to accelerate or decelerate. Set value=10 Up signal Set value=11 DOWN signal</p> <table border="1" data-bbox="411 439 1193 539"> <tr> <td>UP Reference</td> <td>OFF</td> <td>OFF</td> <td>OFF</td> <td>ON</td> </tr> <tr> <td>DOWN Reference</td> <td>ON</td> <td>ON</td> <td>OFF</td> <td>ON</td> </tr> <tr> <td>Status</td> <td>Accelerating</td> <td>Decelerating</td> <td>Hold</td> <td>Hold</td> </tr> </table>  <p>U=UP (Accelerate) status D=DOWN (Decelerate) Status H=HOLD (Hold a certain speed) U1=Accelerate to upper limit value D1=Decelerate to the lower limit.</p> <p>Note: 1. To use UP/DOWN reference, 21-01 must be set as 1. 2. The upper limit speed=the max output frequency (51-04)×upper limit of the frequency reference (42-01). 3. Lower limit speed is the larger one of the lower limit of frequency reference (42-02) or control terminal FIV or FIC. 4. If (44-01=1), the accel/dec el stop reference input, when the power source is “OFF”, the memory hold the current output frequency. 5. The inching reference has priority in performance when it is input during the UP/DOWN reference is being performed. 6. OPE03 will appear if UP and DOWN reference are set at the same time. 7. OPE03 will appear if multifunction terminal “Accelerating stop and decelerating stop” references are set at the same time.</p>	UP Reference	OFF	OFF	OFF	ON	DOWN Reference	ON	ON	OFF	ON	Status	Accelerating	Decelerating	Hold	Hold
UP Reference	OFF	OFF	OFF	ON												
DOWN Reference	ON	ON	OFF	ON												
Status	Accelerating	Decelerating	Hold	Hold												
12, 13	<p>• FJOG reference, RJOG reference [Perform forward and reverse inching reference]. Set value =12 FJOG reference: “ON”, perform forward run inching reference (41-09). Set value=13 FJOG reference: “ON”, perform forward run inching reference (41-09). (Note)1. The FJOG reference and RJOG reference have priority in performance if they are input in run. 2. The inverter will stop with the stop method set by 21-03 if the FJOG reference and RJOG reference are input at the same time and exceed 500ms. 3. FJOG reference and RJOG reference can be set and use respectively.</p>															
14	<p>• Fault Reset [ON: Perform fault reset]</p>															
1B	<p>• Parameter writing forbid OFF: Forbid writing parameter through operator. ON: Permit writing parameter through the operator.</p>															

Set Value	Description																																																																																																																																																																															
1F	<ul style="list-style-type: none"> Terminal FIV, FIC selection [OFF: FIV is main speed frequency], [ON: FIC is the main speed frequency]. Function selection of multifunction input terminal (T1-01~T1-06), not be set as 1F, and the terminal FIC is set as 1F, the main speed frequency is FIC+FIV. 																																																																																																																																																																															
20-2F	<ul style="list-style-type: none"> External fault The inverter will stop or send a warning signal to peripheral machines for the fault of peripheral machines. <table border="1" style="width: 100%; border-collapse: collapse;"> <thead> <tr> <th colspan="2">Set value</th> <th colspan="8">selection method</th> </tr> <tr> <th colspan="2"></th> <th colspan="2">connection point method</th> <th colspan="2">Detection method</th> <th colspan="4">Stop method</th> </tr> <tr> <th>The second digit</th> <th>The second digit</th> <th>Con-connection A input</th> <th>Con-connection B input</th> <th>Detection in fault</th> <th>Detection in run</th> <th>Detective stop, heavy fault</th> <th>Free stop, heavy fault</th> <th>Urgent stop, heavy fault</th> <th>Continue to run light fault</th> </tr> </thead> <tbody> <tr><td rowspan="16" style="text-align: center; vertical-align: middle;">2</td><td>0</td><td style="text-align: center;">○</td><td></td><td style="text-align: center;">○</td><td></td><td style="text-align: center;">○</td><td></td><td></td><td></td></tr> <tr><td>1</td><td></td><td style="text-align: center;">○</td><td style="text-align: center;">○</td><td></td><td style="text-align: center;">○</td><td></td><td></td><td></td></tr> <tr><td>2</td><td style="text-align: center;">○</td><td></td><td></td><td style="text-align: center;">○</td><td style="text-align: center;">○</td><td></td><td></td><td></td></tr> <tr><td>3</td><td></td><td style="text-align: center;">○</td><td></td><td></td><td style="text-align: center;">○</td><td style="text-align: center;">○</td><td></td><td></td></tr> <tr><td>4</td><td style="text-align: center;">○</td><td></td><td></td><td style="text-align: center;">○</td><td></td><td></td><td style="text-align: center;">○</td><td></td></tr> <tr><td>5</td><td></td><td style="text-align: center;">○</td><td></td><td style="text-align: center;">○</td><td></td><td></td><td style="text-align: center;">○</td><td></td></tr> <tr><td>6</td><td style="text-align: center;">○</td><td></td><td></td><td></td><td style="text-align: center;">○</td><td></td><td style="text-align: center;">○</td><td></td></tr> <tr><td>7</td><td></td><td style="text-align: center;">○</td><td></td><td></td><td style="text-align: center;">○</td><td></td><td style="text-align: center;">○</td><td></td></tr> <tr><td>8</td><td style="text-align: center;">○</td><td></td><td></td><td style="text-align: center;">○</td><td></td><td></td><td></td><td style="text-align: center;">○</td></tr> <tr><td>9</td><td></td><td style="text-align: center;">○</td><td></td><td style="text-align: center;">○</td><td></td><td></td><td></td><td style="text-align: center;">○</td></tr> <tr><td>A</td><td style="text-align: center;">○</td><td></td><td></td><td></td><td style="text-align: center;">○</td><td></td><td></td><td style="text-align: center;">○</td></tr> <tr><td>B</td><td></td><td style="text-align: center;">○</td><td></td><td></td><td style="text-align: center;">○</td><td></td><td></td><td style="text-align: center;">○</td></tr> <tr><td>C</td><td style="text-align: center;">○</td><td></td><td></td><td style="text-align: center;">○</td><td></td><td></td><td></td><td style="text-align: center;">○</td></tr> <tr><td>D</td><td></td><td style="text-align: center;">○</td><td></td><td style="text-align: center;">○</td><td></td><td></td><td></td><td style="text-align: center;">○</td></tr> <tr><td>E</td><td style="text-align: center;">○</td><td></td><td></td><td></td><td style="text-align: center;">○</td><td></td><td></td><td style="text-align: center;">○</td></tr> <tr><td>F</td><td></td><td style="text-align: center;">○</td><td></td><td></td><td style="text-align: center;">○</td><td></td><td></td><td style="text-align: center;">○</td></tr> </tbody> </table> <p>Example, if T1-06, terminal BX-RC function selection is set as 24</p> <ul style="list-style-type: none"> If terminal BX and CM is ON, the external fault The external fault is detected at once. If the fault is heavy, the inverter freely stop. 	Set value		selection method										connection point method		Detection method		Stop method				The second digit	The second digit	Con-connection A input	Con-connection B input	Detection in fault	Detection in run	Detective stop, heavy fault	Free stop, heavy fault	Urgent stop, heavy fault	Continue to run light fault	2	0	○		○		○				1		○	○		○				2	○			○	○				3		○			○	○			4	○			○			○		5		○		○			○		6	○				○		○		7		○			○		○		8	○			○				○	9		○		○				○	A	○				○			○	B		○			○			○	C	○			○				○	D		○		○				○	E	○				○			○	F		○			○			○
Set value		selection method																																																																																																																																																																														
		connection point method		Detection method		Stop method																																																																																																																																																																										
The second digit	The second digit	Con-connection A input	Con-connection B input	Detection in fault	Detection in run	Detective stop, heavy fault	Free stop, heavy fault	Urgent stop, heavy fault	Continue to run light fault																																																																																																																																																																							
2	0	○		○		○																																																																																																																																																																										
	1		○	○		○																																																																																																																																																																										
	2	○			○	○																																																																																																																																																																										
	3		○			○	○																																																																																																																																																																									
	4	○			○			○																																																																																																																																																																								
	5		○		○			○																																																																																																																																																																								
	6	○				○		○																																																																																																																																																																								
	7		○			○		○																																																																																																																																																																								
	8	○			○				○																																																																																																																																																																							
	9		○		○				○																																																																																																																																																																							
	A	○				○			○																																																																																																																																																																							
	B		○			○			○																																																																																																																																																																							
	C	○			○				○																																																																																																																																																																							
	D		○		○				○																																																																																																																																																																							
	E	○				○			○																																																																																																																																																																							
	F		○			○			○																																																																																																																																																																							
60	<ul style="list-style-type: none"> DCLNJ reference. [OFF: common act], [ON: perform DCLNJ when the inverter stops (with PG vector initial excitation). Perform DCLNJ when the inverter stops and DCLNJ is input. The DCLNJ reference is got rid of and the run start when the run reference or inching reference is input. (Run has priority). 																																																																																																																																																																															

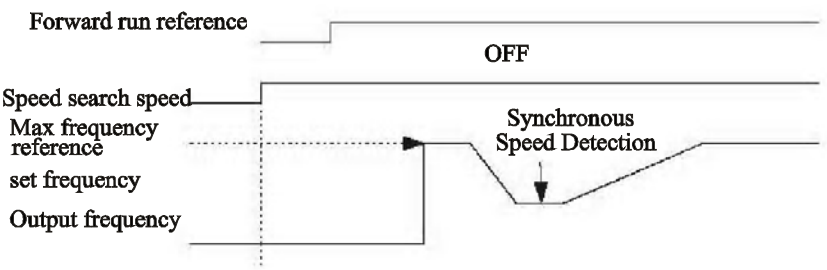
Set Value	Description
61. 62	<ul style="list-style-type: none"> Speed search reference <p>In commercial power source /inverter switch run occasion, speed search function should be used to start motor in free run to prevent jump of the inverter.</p> <p>Set value= 61, speed search start from the max frequency.</p> <p>Set value =62 speed search start from the max setting.</p> <p>In base block, speed search reference is "ON" ,the run reference is input, after the min base block time (P2-03), the speed search will begin.</p>  <p>Note: 1.In instant continuous run method, regardless whether there is run reference or speed search reference, the speed search act will be perform from the current output speed. After speed search, the run reference will be performed.</p> <p>2.The speed search reference value 61, 62 can be set at the same time, or else, OPE03 will appear.</p>
71	Speed/torque control switch (ON: torque control).
72	Zero servo (ON: zero servo):The input performs the zero servo function (29-01, 29-02) .

Parameter No.	Name	Set value before delivery	Description					Remark	
	Function selection of multifunction input terminal		Function selection of terminal RA, Y1, Y2						
			Set value	Function	V/F	V/F+P	VVC	FVC+P	
			00	In run	○	○	○	○	
			01	Zero speed	○	○	○	○	
T2-01	Function selection of terminal RA-RC	0	02	Frequency arrival 1	○	○	○	○	
			03	Any frequency arrival	○	○	○	○	
			04	Frequency detection 1	○	○	○	○	
			05	Frequency detection 2	○	○	○	○	
T2-02	Function Selection of terminal Y1-YC	1	06	The preparation of the inverter for run has been completed.	○	○	○	○	
			07	In Detection of undervoltage	○	○	○	○	
T2-03	Function selection of terminal Y21-YC	2	08	In Base block (A point output)	○	○	○	○	
			09	Frequency indication method	○	○	○	○	
			0A	Run indication method	○	○	○	○	
			0B	Over-torque detection (connection A output)	○	○	○	○	
			0C	Frequency indication loss	○	○	○	○	
			0D	Brake resistor is bad	○	○	○	○	
			0E	Fault	○	○	○	○	
			0F	Not be used	-	-	-	-	
			10	Alarm	○	○	○	○	
			11	In fault reset	○	○	○	○	
			12	Timer output	○	○	○	○	
			13	Frequency arrival 2	○	○	○	○	
			14	Any frequency arrival 2	○	○	○	○	
			15	Frequency detection 3	○	○	○	○	
			16	Frequency detection 4	○	○	○	○	
			17	Over-torque detection 1 (Connection point B output)	○	○	○	○	
			18	Over-torque detection 2 (Connection point A output)	○	○	○	○	
			19	Over-torque detection 2 (Connection point B output)	○	○	○	○	
			1A	In reverse run	○	○	○	○	
			1B	In Base block	○	○	○	○	
			1C	Not be used	-	-	-	-	
			1D	Electrical Regeneration Method	×	×	×	○	
			1E	Fault Restart	○	○	○	○	
			1F	OLI pre-alarm	○	○	○	○	
			20	OH pre-alarm	○	○	○	○	
			21~2	Not be used	-	-	-	-	
			F						
			30	In torque limit	×	×	○	○	
			31	In speed limit	×	×	×	○	
			32	Not be used	-	-	-	-	
			33	zero servo is complete	×	×	×	○	
			37	In run 2	○	○	○	○	
			34~3	Not be used	-	-	-	-	
			F						

V/F-V/F control, V/F+P= V/F W/PG FDBK control
VVC= OPEN LOOP VECTOR control, FVC+P= FLUX VECTOR control.

Set Value	Description
	<ul style="list-style-type: none"> Function selection of multifunction output terminals , output function selection of control loop terminal RA, Y1 and Y2.
00	<ul style="list-style-type: none"> In run The connection point is "ON" when the inverter has voltage output or run reference input.
01	<ul style="list-style-type: none"> In zero speed In V/F W/PG FDBK control, the connection is "ON" when the output frequency of the inverter is lower than "The min output frequency " (51-09). In vector control with PG, the connection is "ON" when the motor speed is lower than "Zero speed level" (22-01)
02	<ul style="list-style-type: none"> Frequency arrival 1 If the output frequency is in the following detection frequency range, the connection point is "ON" frequency reference $-P2-04 \leq SFS \text{ output} \leq \text{frequency reference} + P4-02$
03	<ul style="list-style-type: none"> Any frequency arrival 1 If the output frequency meets the condition that set value =2 and is in the following diction frequency range, the connection point is "ON". $P4-01-P4-02SFS \text{ output (without sign)} P4-01+P4-02$
04	<ul style="list-style-type: none"> Frequency detection 1 The connection is "ON" when the output frequency is below the following detection frequency range: $SFS \text{ output (Without sign)} \leq P4-01+P4-02$
05	<ul style="list-style-type: none"> Frequency detection 2 The connection point is "ON" if the output frequency is above the following diction frequency range: $SFS \text{ output (Without sign)} \geq P4-01$
06	<ul style="list-style-type: none"> The preparation of the inverter for run is complete. The connection point is "OFF" if the inverter has completed the preparation to run.
07	<ul style="list-style-type: none"> In undervoltage detection The connection point is "ON" if the voltage of main loop or control loop is over-low , or the electro-magnetic contactor is "OFF".
08	<ul style="list-style-type: none"> Base block Then connection point is "ON" if the inverter output is in base block.
09	<ul style="list-style-type: none"> Frequency reference method The connection point is "ON" if the frequency reference in run is from control loop terminals or options. The connection point is "ON" if the frequency reference in run is from the operator.
0A	<ul style="list-style-type: none"> Run reference method The connection point is "OFF" if the frequency reference in run is from control loop or option. The connection is "OFF" if the frequency reference in run is from the operator.
0B	<ul style="list-style-type: none"> The over-torque detection 1 The connection point is "ON" if the over-torque is detected.

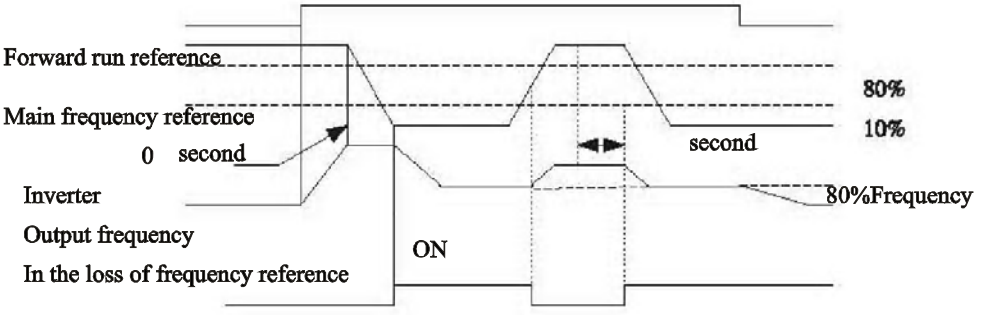
Set Value	Description
0C	<ul style="list-style-type: none"> Frequency reference loss The connection point is "ON" if the frequency reference is lost. 
0D	<ul style="list-style-type: none"> Brake resistor is not good. The connection point is "ON" if the brake resistor is overheat or the transistor of the brake resistor is fault.
0E	<ul style="list-style-type: none"> Fault The connection point is "ON" when it is in fault (except CPF00, CPF01).
10	<ul style="list-style-type: none"> Alarm The connection point is "ON" in alarm.
11	<ul style="list-style-type: none"> In Fault reset The connection point is "ON" in fault reset.
12	<ul style="list-style-type: none"> TIMER The connection point is "ON" if the output of the multifunction terminal that is set as "TIMER" function input.
13	<ul style="list-style-type: none"> Frequency arrival 2 The connection is "ON" if the output frequency is in the following frequency detection range : Frequency reference -P4-04 ≤ SFS output ≤ frequency reference +P4-04
14	<ul style="list-style-type: none"> Any frequency arrival 2 The connection point is "ON" if the output frequency meets the set value and is in the following frequency detection range: P3-03-P4-04 ≤ SFS output(with sign) ≤ P4-03+P4-04
15	<ul style="list-style-type: none"> Frequency detection 3 The connection point is "ON" if the frequency output is below the following frequency detection range: SFS output (With sign) ≤ P4-03
16	<ul style="list-style-type: none"> Frequency detection 4 The connection point is "ON" if the output frequency is above the following frequency detection range : SFS output (with sign) ≤ P4-03
17	<ul style="list-style-type: none"> Over-torque detection 1 The connection point is "OFF" if the over-torque detection 1 is detected.
18	<ul style="list-style-type: none"> Over-torque detection 2 The connection point is "OFF" if the over-torque detection 2 is detected.
19	<ul style="list-style-type: none"> Over-torque detection 3 The connection point is "OFF" if the over-torque detection 3 is detected.

Set Value	Description
1A	<ul style="list-style-type: none"> • In reverse run The connection point is "ON" in reverse run.
1B	<ul style="list-style-type: none"> • base block The connection is "OFF" in base block.
1D	<ul style="list-style-type: none"> • Electric/Regeneration method The connection point is "ON" in Vector control with PG method in regeneration method.
1E	<ul style="list-style-type: none"> • Fault restart The connection point is "ON" in the fault restart.
1F	<ul style="list-style-type: none"> • OL1 early-warning The connection point is "ON" if the accumulative value of the electric thermal overload relay reaches at 90% of fault detection level.
20	<ul style="list-style-type: none"> • OH early-warning The connection point is "ON" if the cooling fin's temperature exceeds the overhead temperature.
30	<ul style="list-style-type: none"> • In torque limit The connection point is "ON" in torque limit.
31	<ul style="list-style-type: none"> • In speed limit The connection point is "ON" if the speed reaches the speed limit level in torque control.
33	<ul style="list-style-type: none"> • Zero servo complete The connection point is "ON" after the zero servo has been completed.
37	<ul style="list-style-type: none"> • In run The connection point is "ON" in run except for base block , DCLNJ and initial excitation.

Parameter No.	Name	Set value before leaving factory	Description	Remark																																																																																																																																												
T3-01	Signal level selection of the terminal FIV	0	<table border="1"> <thead> <tr> <th>Set value</th> <th>Description</th> </tr> </thead> <tbody> <tr> <td>0</td> <td>0~+10V input</td> </tr> <tr> <td>1</td> <td>-10~+10V input</td> </tr> </tbody> </table>	Set value	Description	0	0~+10V input	1	-10~+10V input	• Resolution[11bit+input signal]																																																																																																																																						
Set value	Description																																																																																																																																															
0	0~+10V input																																																																																																																																															
1	-10~+10V input																																																																																																																																															
T3-02	The input gain of the terminal FIV	100	The gain level setting when the frequency reference voltage is 10V input.																																																																																																																																													
T3-03	The input bias of the terminal FIV	0.0	The bias level setting when the frequency reference voltage is 10V input.																																																																																																																																													
T3-04	The signal level selection of the terminal MFI	0	<table border="1"> <thead> <tr> <th>Set value</th> <th>Description</th> </tr> </thead> <tbody> <tr> <td>0</td> <td>0~+10V input</td> </tr> <tr> <td>1</td> <td>-10~+10V input</td> </tr> </tbody> </table>	Set value	Description	0	0~+10V input	1	-10~+10V input	• Resolution[11bit+input signal]																																																																																																																																						
Set value	Description																																																																																																																																															
0	0~+10V input																																																																																																																																															
1	-10~+10V input																																																																																																																																															
T3-05	Function selection of the terminal MFI	0	<p>Terminal MFI multifunction analog reference set vale</p> <table border="1"> <thead> <tr> <th>Set value</th> <th>Function</th> <th>V/F*</th> <th>V/FPG*</th> <th>VVC*</th> <th>FVC*</th> <th>Input level</th> </tr> </thead> <tbody> <tr> <td>00</td> <td>Auxiliary frequency reference</td> <td>○</td> <td>○</td> <td>○</td> <td>○</td> <td>±100%/±10V</td> </tr> <tr> <td>01</td> <td>Frequency gain</td> <td>○</td> <td>○</td> <td>○</td> <td>○</td> <td>100%/10V</td> </tr> <tr> <td>02</td> <td>Frequency basis</td> <td>○</td> <td>○</td> <td>○</td> <td>○</td> <td>±100%/±10V</td> </tr> <tr> <td>04</td> <td>Voltage basis</td> <td>○</td> <td>○</td> <td>×</td> <td>×</td> <td>100%/10V</td> </tr> <tr> <td>05</td> <td>Accel/decel time shorten coefficient</td> <td>○</td> <td>○</td> <td>○</td> <td>○</td> <td>100%/10V</td> </tr> <tr> <td>06</td> <td>DCLNJ current</td> <td>○</td> <td>○</td> <td>○</td> <td>○</td> <td>100%/10V</td> </tr> <tr> <td>07</td> <td>Torque detection level in run</td> <td>○</td> <td>○</td> <td>○</td> <td>○</td> <td>100%/10V</td> </tr> <tr> <td>08</td> <td>Speed loss prevent level in run</td> <td>-</td> <td>-</td> <td>-</td> <td>-</td> <td>100%/10V</td> </tr> <tr> <td>09</td> <td>Frequency reference lower limit level</td> <td>○</td> <td>○</td> <td>○</td> <td>○</td> <td>100%/10V</td> </tr> <tr> <td>0A</td> <td>Setting forbidden frequency</td> <td>○</td> <td>○</td> <td>○</td> <td>○</td> <td>100%/10V</td> </tr> <tr> <td>0B</td> <td>PID feedback</td> <td>○</td> <td>○</td> <td>○</td> <td>○</td> <td>±100%/±10V</td> </tr> <tr> <td>0C~0F</td> <td>not be used</td> <td>×</td> <td>×</td> <td>×</td> <td>×</td> <td>-</td> </tr> <tr> <td>10</td> <td>Torque limit of forward run side</td> <td>×</td> <td>×</td> <td>○</td> <td>○</td> <td>100%/10V</td> </tr> <tr> <td>11</td> <td>Torque limit of reverse run side</td> <td>×</td> <td>×</td> <td>○</td> <td>○</td> <td>100%/10V</td> </tr> <tr> <td>12</td> <td>Torque limit of Regeneration side</td> <td>×</td> <td>×</td> <td>○</td> <td>○</td> <td>100%/10V</td> </tr> <tr> <td>13</td> <td>Torque reference Torque limit</td> <td>×</td> <td>×</td> <td>○</td> <td>○</td> <td>±100%/±10V</td> </tr> <tr> <td>14</td> <td>Torque compensation (bias)</td> <td>×</td> <td>×</td> <td>○</td> <td>○</td> <td>±100%/±10V</td> </tr> <tr> <td>15</td> <td>Positive/negative torque limit</td> <td>×</td> <td>×</td> <td>○</td> <td>○</td> <td>±100%/10V</td> </tr> <tr> <td>16~1F</td> <td>Not be used</td> <td>-</td> <td>-</td> <td>-</td> <td>-</td> <td>-</td> </tr> </tbody> </table> <p>V/F=V/F control, V/F PG= V/F W/PG FDBK control, VVC= OPEN LOOP VECTOR control</p> <p>(Note) The smaller one of parameter (P7-01~04) and analog reference has priority to be torque limit.</p>	Set value	Function	V/F*	V/FPG*	VVC*	FVC*	Input level	00	Auxiliary frequency reference	○	○	○	○	±100%/±10V	01	Frequency gain	○	○	○	○	100%/10V	02	Frequency basis	○	○	○	○	±100%/±10V	04	Voltage basis	○	○	×	×	100%/10V	05	Accel/decel time shorten coefficient	○	○	○	○	100%/10V	06	DCLNJ current	○	○	○	○	100%/10V	07	Torque detection level in run	○	○	○	○	100%/10V	08	Speed loss prevent level in run	-	-	-	-	100%/10V	09	Frequency reference lower limit level	○	○	○	○	100%/10V	0A	Setting forbidden frequency	○	○	○	○	100%/10V	0B	PID feedback	○	○	○	○	±100%/±10V	0C~0F	not be used	×	×	×	×	-	10	Torque limit of forward run side	×	×	○	○	100%/10V	11	Torque limit of reverse run side	×	×	○	○	100%/10V	12	Torque limit of Regeneration side	×	×	○	○	100%/10V	13	Torque reference Torque limit	×	×	○	○	±100%/±10V	14	Torque compensation (bias)	×	×	○	○	±100%/±10V	15	Positive/negative torque limit	×	×	○	○	±100%/10V	16~1F	Not be used	-	-	-	-	-	
Set value	Function	V/F*	V/FPG*	VVC*	FVC*	Input level																																																																																																																																										
00	Auxiliary frequency reference	○	○	○	○	±100%/±10V																																																																																																																																										
01	Frequency gain	○	○	○	○	100%/10V																																																																																																																																										
02	Frequency basis	○	○	○	○	±100%/±10V																																																																																																																																										
04	Voltage basis	○	○	×	×	100%/10V																																																																																																																																										
05	Accel/decel time shorten coefficient	○	○	○	○	100%/10V																																																																																																																																										
06	DCLNJ current	○	○	○	○	100%/10V																																																																																																																																										
07	Torque detection level in run	○	○	○	○	100%/10V																																																																																																																																										
08	Speed loss prevent level in run	-	-	-	-	100%/10V																																																																																																																																										
09	Frequency reference lower limit level	○	○	○	○	100%/10V																																																																																																																																										
0A	Setting forbidden frequency	○	○	○	○	100%/10V																																																																																																																																										
0B	PID feedback	○	○	○	○	±100%/±10V																																																																																																																																										
0C~0F	not be used	×	×	×	×	-																																																																																																																																										
10	Torque limit of forward run side	×	×	○	○	100%/10V																																																																																																																																										
11	Torque limit of reverse run side	×	×	○	○	100%/10V																																																																																																																																										
12	Torque limit of Regeneration side	×	×	○	○	100%/10V																																																																																																																																										
13	Torque reference Torque limit	×	×	○	○	±100%/±10V																																																																																																																																										
14	Torque compensation (bias)	×	×	○	○	±100%/±10V																																																																																																																																										
15	Positive/negative torque limit	×	×	○	○	±100%/10V																																																																																																																																										
16~1F	Not be used	-	-	-	-	-																																																																																																																																										

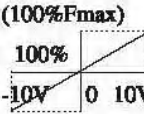
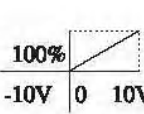
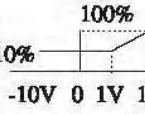
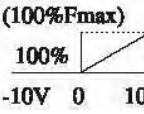
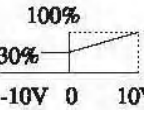
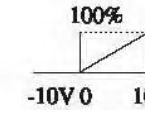
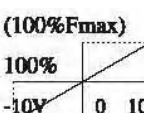
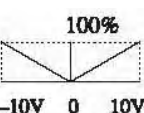
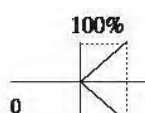
Parameter No.	Name	Set value before leaving factory	Description	Remark
			<ul style="list-style-type: none"> • FGAIN (set value =01) • VBLAS (Set value=04) • DCLNJ current (Set value=0) • Over-torque detection level(Set value=7) • Auxiliary frequency reference (Set value=7) • Frequency reference drop (Set value=9) • FBIAS (Set value=02) • PID Feedback (Set value=08) • Set forbidden frequency (Set value=A) • Accel/decel compression coefficient (Set value=05) <div style="display: flex; justify-content: space-around; align-items: flex-end;"> <div style="text-align: center;"> <p>(100%Fmax)</p>  </div> <div style="text-align: center;"> <p>100%</p>  </div> <div style="text-align: center;"> <p>100%</p>  </div> </div> <ul style="list-style-type: none"> • DCLNJ current Set value=06 • Speed loss level in run Set value=08 • Forward run side torque limit Set value=09 <div style="display: flex; justify-content: space-around; align-items: flex-end; margin-top: 10px;"> <div style="text-align: center;"> <p>(100%Fmax)</p>  </div> <div style="text-align: center;"> <p>100%</p>  </div> <div style="text-align: center;"> <p>100%</p>  </div> </div> <ul style="list-style-type: none"> • torque reference (Set value=07) • Torque limit (Set value=10, 11, 12) • Forward run side torque li (Set value=15) • torque compensation (Set value=14) <div style="display: flex; justify-content: space-around; align-items: flex-end; margin-top: 10px;"> <div style="text-align: center;"> <p>(100%Fmax)</p>  </div> <div style="text-align: center;"> <p>100%</p>  </div> <div style="text-align: center;"> <p>100%</p>  </div> </div>	
T3-06	The input gain of the terminal MFI	100	[Gain] level gain setting when the terminal MFI input is 10V.	
T3-07	The input bias of the terminal MFI	0.0	[Bias] level gain setting when the terminal MFI input is 10 V.	

Parameter No.	Name	Set value before leaving factory	Description	Remark								
T3-08	The signal level selection of the terminal FIC	2	<table border="1"> <thead> <tr> <th>Set vale</th> <th>Description</th> </tr> </thead> <tbody> <tr> <td>0</td> <td>0~+10V input</td> </tr> <tr> <td>1</td> <td>-10V~+10V input</td> </tr> <tr> <td>2</td> <td>4~20mA input</td> </tr> </tbody> </table>	Set vale	Description	0	0~+10V input	1	-10V~+10V input	2	4~20mA input	
			Set vale	Description								
0	0~+10V input											
1	-10V~+10V input											
2	4~20mA input											
(Note) Please turn on the J1 on the panel and move left when the analog reference level changes from current input [4-20 mA] to voltage input [0~10V or ~10V~10V].												
T3-09	Function selection of the terminal FIC	1F	<p>Multifunction input terminal inputs set value, the function content can refers to T3-05, but the set value 00 and 1F are different from T3-05: [0: not be used] [1F: Main frequency reference] The main frequency is FIC+FIC if the input function selection of the multifunction terminal (T1-01~T1-06) is not set as 1F (the function selection of terminal FIV, FIC), while terminal FIC's function is set as 1F (T3-09 main speed frequency reference).</p>	• Resolution 10 bit								
T3-10	The input gain of terminal FIC	100.0	The gain level setting when the terminal FIC input is 10V.									
T3-11	The input bias of terminal FIC	0.0	The setting of bias when the terminal FIC input is 0V.									
T3-12	Analog input filter constant	0.00	A certain delay filter constant setting of terminal FIV, FIC, MFI									
T4-01	Monitor output selection of the terminal MV+MOC	2	The monitored items are MI-XX items, selection of MI+MOC output items.	• Resolution: 9 bit +input signal								
T4-02	The output gain of terminal MV+MOC	1.00	The output level×Set value (T4-02)									
T4-03	The monitor output bias of the terminal MA+MOC.	0.0	The output level of the monitored parameter×Set value (T4-02)+Set value (T4-03)									
T4-04	The monitor output selection of the terminal MA+MOC	3	Monitored items are that of M1-XX. The selection of terminal MA+MOC (Multifunction analog monitor) output items.									
T4-05	The output gain of the terminal MA+MOC	0.50	The output level of the monitored parameter×Set value (T4-05)									
T4-06	The output bias of the terminal MA+MOC	0.0	The output level of the monitored parameter×Set value (T4-02)+ Set value (T4-03).									
T4-07	Analog Output signal level selection	0	<table border="1"> <thead> <tr> <th>Ser value</th> <th>Description</th> </tr> </thead> <tbody> <tr> <td>0</td> <td>0~+10V input</td> </tr> <tr> <td>1</td> <td>-10V~+10V input</td> </tr> </tbody> </table>	Ser value	Description	0	0~+10V input	1	-10V~+10V input			
Ser value	Description											
0	0~+10V input											
1	-10V~+10V input											
T5-01	Setting station address in communication	1F	The inverter's MODBUS communication station setting.	MODBUS								
T5-02	Transmission speed selection	3	[0: 1200], [1:2400], [2: 4800], [3: 9600], [3: 19200]	Unit: BPS								
T5-03	Transmission parity selection	0	[0: no parity], [1: even parity], [2: odd parity]	MODBUS								

7.8 Parameter Group

Parameter No.	Name	Set Value before leaving Factory	Description	Remark										
T5-04	Transmission fault selection	3	<table border="1"> <thead> <tr> <th>Set Value</th> <th>Description</th> </tr> </thead> <tbody> <tr> <td>0</td> <td>Decelerated stop(Decelerating time: 31-02)</td> </tr> <tr> <td>1</td> <td>Urgent stop (Decelerating time: 31-09)</td> </tr> <tr> <td>2</td> <td>Free stop</td> </tr> <tr> <td>3</td> <td>Continue to run</td> </tr> </tbody> </table>	Set Value	Description	0	Decelerated stop(Decelerating time: 31-02)	1	Urgent stop (Decelerating time: 31-09)	2	Free stop	3	Continue to run	
Set Value	Description													
0	Decelerated stop(Decelerating time: 31-02)													
1	Urgent stop (Decelerating time: 31-09)													
2	Free stop													
3	Continue to run													
T5-05	Transmission fault detection	1	<table border="1"> <thead> <tr> <th>Set value</th> <th>Description</th> </tr> </thead> <tbody> <tr> <td>0</td> <td>Transmission fault is not be detected</td> </tr> <tr> <td>1</td> <td>Transmission fault is detected , 21-01, 21-02 set value more than 2, transmission signal two second later, not receive acknowledgement signal, the inverter will display transmission fault and act according to the setting of Y5-04.</td> </tr> </tbody> </table>	Set value	Description	0	Transmission fault is not be detected	1	Transmission fault is detected , 21-01, 21-02 set value more than 2, transmission signal two second later, not receive acknowledgement signal, the inverter will display transmission fault and act according to the setting of Y5-04.					
Set value	Description													
0	Transmission fault is not be detected													
1	Transmission fault is detected , 21-01, 21-02 set value more than 2, transmission signal two second later, not receive acknowledgement signal, the inverter will display transmission fault and act according to the setting of Y5-04.													
P1-01	Motor protection selection	1	<table border="1"> <thead> <tr> <th>Set value</th> <th>Description</th> </tr> </thead> <tbody> <tr> <td>0</td> <td>Electric thermal relay is unavailable</td> </tr> <tr> <td>1</td> <td>Electric thermal relay is available</td> </tr> </tbody> </table> <p>1Please install one electric thermal relay at every motor if one inverter drives more than one motor for overload protection. 2Because when the power source of the inverter is turned off, the detected value of the motor temperature will cleared as 0, this function may be unavailable when be used in the occasion that the power source of the inverter is turned off in run.</p>	Set value	Description	0	Electric thermal relay is unavailable	1	Electric thermal relay is available					
Set value	Description													
0	Electric thermal relay is unavailable													
1	Electric thermal relay is available													
P1-02	Motor protection time	1.0	<p>Setting protection time of the electric thermal relay when the motor is continuously running above the rated current and with 150% overload.</p> <p>Please set the value according to the overload ability of Time characteristic of the electric thermal relay, for example, P1-02=1.0, 60Hz, run.</p>											
P2-01	Act selection in transient power failure.	0	<p>When transient power failure occurs, the inverter detects the failure and stop. The selection is that whether the inverter perform “restart run” after the power supply is recovered.</p> <table border="1"> <thead> <tr> <th>Set value</th> <th>Description</th> </tr> </thead> <tbody> <tr> <td>0</td> <td>Restart run is available after power supply is recovered.</td> </tr> <tr> <td>1</td> <td>Restart run is available after power supply is recovered.</td> </tr> <tr> <td>2</td> <td>Restart run is available after power supply is recovered. The inverter will perform the restart run method after the power supply is recovered once the control power source is in the act arrange, regardless the time setting of P2-02. The fault connection point will not act.</td> </tr> </tbody> </table>	Set value	Description	0	Restart run is available after power supply is recovered.	1	Restart run is available after power supply is recovered.	2	Restart run is available after power supply is recovered. The inverter will perform the restart run method after the power supply is recovered once the control power source is in the act arrange, regardless the time setting of P2-02. The fault connection point will not act.			
Set value	Description													
0	Restart run is available after power supply is recovered.													
1	Restart run is available after power supply is recovered.													
2	Restart run is available after power supply is recovered. The inverter will perform the restart run method after the power supply is recovered once the control power source is in the act arrange, regardless the time setting of P2-02. The fault connection point will not act.													

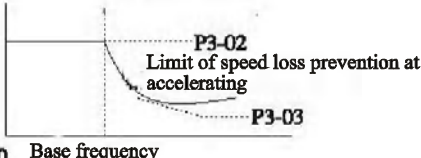
Parameter No.	Name	Set Value before leaving Factory	Description	Remark
P2-02	The guarantee time of transient power failure	0.7	Setting the permitted power failure time, when the transient power failure occurs and the selection of the (P2-01=1) is performing the restart run method. If the power supply can be recovered in the guarantee time, the inverter will perform restart run method; otherwise, the fault connection point will act after guarantee.	
P2-03	Min base block time	0.5	When the inverter performs the restart run method after power failure is detected, the motor remains residual voltage. Excessive large current may pass through the motor and lead to inverter fault detection. The min base block time is the standby time from the power supply is recovered at the power source to motor residual voltage thoroughly disappears. This function is available if P2-02 is set as 1 or 2. The min base block time power supply recovery time. The restart run method will be performed after the min base block time in case of power failure. The min base block time < power supply recovery time. The restart run method will be performed after the power supply recovery time.	
P2-04	Voltage reset time	0.3	The inverter performs the speed search reference to detect the motor speed at the restart run after transient power failure. The voltage reset time refers to the time from the complete of speed search to the voltage recovers the normal value of V/F curve value. 220 V grade: 0V 220V. 440V grade: 0-440V.	
P2-05	Undervoltage detection level	190	Set the voltage value of the DC bus bar of the main loop of the inverter as the undervoltage detection level. The set value should be smaller than the verified value when the input side has AC reactor. 220V grade: 190 VDC 440V grade: 380 VDC	220V grade: 150-210VDC 440V grade: 300-420 VDC.
P3-01	Function selection of Speed loss prevention in accelerating	1	The motor speed loss prevention is unavailable in accelerating.	
			Set value	Description
			0	The motor speed loss prevention is unavailable in accelerating. Inverter will put out frequency with the set acceleration, regardless the motor status. The motor may have speed loss if the load is heavy.
			1	The motor speed loss prevention is available at accelerating. Decrease acceleration according automatically to the motor DC current to avoid motor speed loss
2	The optimal accelerating method Monitor the motor current, regardless the accel/ decel time setting, accelerate the motor with the optimal acceleration at the optimal moment.			
P3-02	Level of speed loss prevent in accelerating	150	When the motor speed loss function (P3-01=1) or optical accelerating method (P3-01=2) is selected, the inverter automatically adjust the acceleration to prevent the motor from exceeding this set value when continuing to accelerate.	
P3-03	Limit of speed loss prevention level	100	The speed loss prevention level descends with the accelerating when the motor is run with fixed output. The range of fixed torque The range of fixed output Base frequency Limit of speed loss prevention at accelerating The range of fixed torque The range of fixed output 	

Parameter No.	Name	Set Value before leaving Factory	Description	Remark								
P3-04	Function selection of speed loss prevention at decelerating	1	<table border="1"> <thead> <tr> <th>Set value</th> <th>Description</th> </tr> </thead> <tbody> <tr> <td>0</td> <td>The speed loss is unavailable at decelerating. The inverter will decelerate according to the set decelerating time. If the decelerating is too short, the inverter will stop output when the voltage is detected at decelerating.</td> </tr> <tr> <td>1</td> <td>The speed loss prevention function is available at decelerating. The deceleration will be descended automatically according to the voltage of the main loop to prevent from overvoltage.</td> </tr> <tr> <td>2</td> <td>The optical decelerating method The inverter will decelerate with the optical deceleration in the shortest time, regardless the setting of the decelerating time.</td> </tr> </tbody> </table>	Set value	Description	0	The speed loss is unavailable at decelerating. The inverter will decelerate according to the set decelerating time. If the decelerating is too short, the inverter will stop output when the voltage is detected at decelerating.	1	The speed loss prevention function is available at decelerating. The deceleration will be descended automatically according to the voltage of the main loop to prevent from overvoltage.	2	The optical decelerating method The inverter will decelerate with the optical deceleration in the shortest time, regardless the setting of the decelerating time.	
Set value	Description											
0	The speed loss is unavailable at decelerating. The inverter will decelerate according to the set decelerating time. If the decelerating is too short, the inverter will stop output when the voltage is detected at decelerating.											
1	The speed loss prevention function is available at decelerating. The deceleration will be descended automatically according to the voltage of the main loop to prevent from overvoltage.											
2	The optical decelerating method The inverter will decelerate with the optical deceleration in the shortest time, regardless the setting of the decelerating time.											
P3-05	Function selection of speed loss in run.	1	<table border="1"> <thead> <tr> <th>Set value</th> <th>Description</th> </tr> </thead> <tbody> <tr> <td>0</td> <td>The speed loss prevention function is unavailable in run</td> </tr> <tr> <td>1</td> <td>The speed loss prevention function is available in run.</td> </tr> <tr> <td>2</td> <td>The speed loss prevention function is available.</td> </tr> </tbody> </table>	Set value	Description	0	The speed loss prevention function is unavailable in run	1	The speed loss prevention function is available in run.	2	The speed loss prevention function is available.	
Set value	Description											
0	The speed loss prevention function is unavailable in run											
1	The speed loss prevention function is available in run.											
2	The speed loss prevention function is available.											
P3-06	The level of speed loss prevention in run	160	<p>Set the inverter output current level to start up the speed loss prevention function in run.</p> <p>Detection time 100ms The act of speed loss prevention in run</p>									
P4-01	Frequency detection level	0.0	The setting value of speed consistency frequency detection (the output direction is not included when detection).									
P4-02	The width of frequency detection	2.0	The width setting of the P4-01 frequency detection									
P4-03	Frequency detection level (+/-)	0.0	The set value of frequency consistency detection. (The output direction is included when detection).									
P4-04	The width of frequency detection	2.0	Set the width of P4-03 frequency detection level									

7.81 Detection Act Description of Frequency Detection Relationship

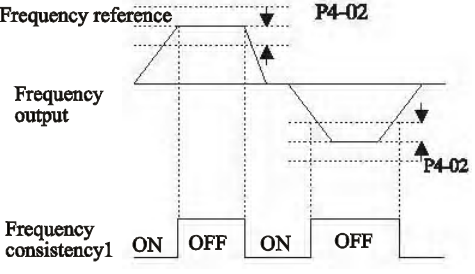
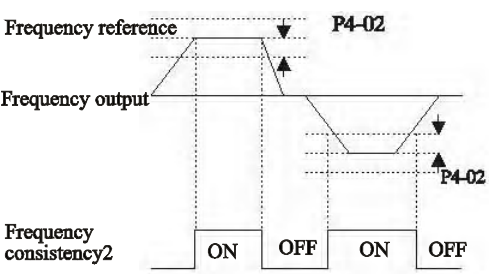
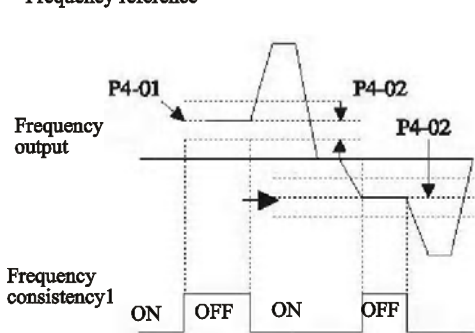
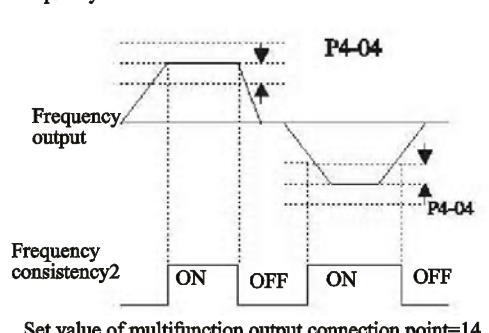
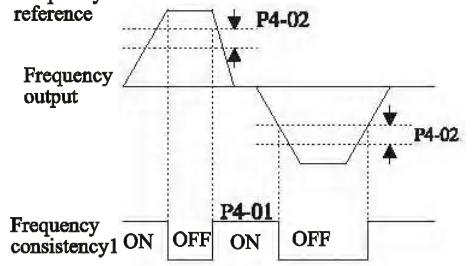
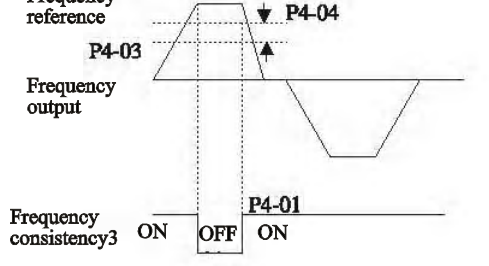
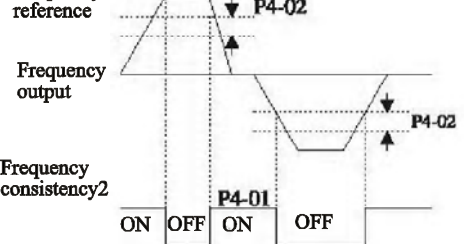
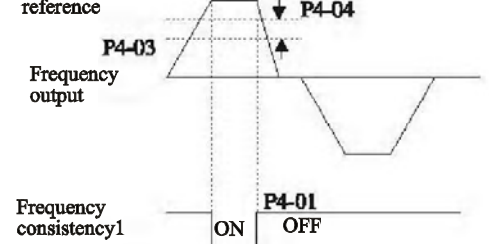
Relevant Parameter	P4-01 (Frequency detection level)P4-02 (Frequency detection width)	P4-03 (Frequency detection level)P4-04 (Frequency detection width)
	Frequency arrival 1	Frequency arrival 2
Frequency arrival	 <p>Set value of multifunction output connection point=02</p>	 <p>Set value of multifunction output connection point=13</p>
	Any frequency arrival 1	Any frequency arrival 2
Any frequency arrival	 <p>Set value of multifunction output connection point=04</p>	 <p>Set value of multifunction output connection point=14</p>
	Frequency consistency detection 1	Frequency consistency detection 3
Frequency detection	 <p>Set value of multifunction output connection point=04</p>	 <p>Set value of multifunction output connection point=15</p>
	Frequency consistency detection 1	Frequency consistency detection 1
Frequency detection	 <p>Set value of multifunction output connection point=05</p>	 <p>Set value of multifunction output connection point=16</p>

Parameter No.	Name	Set value before leaving factory	Description	Remark														
P4-05	The act section at the loss of frequency	0	<p>It is the treating method selection when the frequency references from control terminals change sharply.</p> <table border="1"> <thead> <tr> <th>Set value</th> <th>Description</th> </tr> </thead> <tbody> <tr> <td>0</td> <td>Common run (follow the change of frequency references).</td> </tr> <tr> <td>2</td> <td>The inverter will go on run with the first 80% of the changed frequency reference if the frequency references from the control terminals change 90% sharply within 400 ms.</td> </tr> </tbody> </table>	Set value	Description	0	Common run (follow the change of frequency references).	2	The inverter will go on run with the first 80% of the changed frequency reference if the frequency references from the control terminals change 90% sharply within 400 ms.									
Set value	Description																	
0	Common run (follow the change of frequency references).																	
2	The inverter will go on run with the first 80% of the changed frequency reference if the frequency references from the control terminals change 90% sharply within 400 ms.																	
P5-01	The number of abnormal restart	0	<p>The abnormal restart refers to function that when the fault occurs, the inverter reset the restart in inner to continue run. The act of abnormal restart.</p> <p>The inverter blocks the output within the min base block time (P2-03) and the digital operator displays the fault when the fault has been detected.</p> <p>The inverter will automatically reset the fault in the min base block time, and perform the speed search, starting from the output frequency when the fault occurs.</p> <p>3.If the number of faults exceeds that of the restart, the inverter will not perform abnormal restart and block the output; the fault connection point will act.</p> <p>The number of the abnormal restarts will be cleared as 0 in the following conditions: The fault doesn't occur again within ten minute. The fault reset signal of the control input terminals or digital operator is input. The power source of the inverter is turned OFF and then turned ON. The abnormal restart will not be performed in the following faults:</p> <table> <tr> <td>UV2: Voltage of the control loop</td> <td>DEV: Speed deviation is excessive large</td> </tr> <tr> <td>UV3: The contactor of the main loop fault.</td> <td>PGO: PG disconnection</td> </tr> <tr> <td>SC: Load short circuit</td> <td>OPR: Parameter fault</td> </tr> <tr> <td>OH: Overheat</td> <td>CE: Transmission error</td> </tr> <tr> <td>EF: Run reference fault</td> <td>EF3-8: External fault</td> </tr> <tr> <td>OS: Overspeed</td> <td>ERR: EEPROM writing fault</td> </tr> <tr> <td>SVE: Zero servo error</td> <td>CF: Control fault</td> </tr> </table>	UV2: Voltage of the control loop	DEV: Speed deviation is excessive large	UV3: The contactor of the main loop fault.	PGO: PG disconnection	SC: Load short circuit	OPR: Parameter fault	OH: Overheat	CE: Transmission error	EF: Run reference fault	EF3-8: External fault	OS: Overspeed	ERR: EEPROM writing fault	SVE: Zero servo error	CF: Control fault	
UV2: Voltage of the control loop	DEV: Speed deviation is excessive large																	
UV3: The contactor of the main loop fault.	PGO: PG disconnection																	
SC: Load short circuit	OPR: Parameter fault																	
OH: Overheat	CE: Transmission error																	
EF: Run reference fault	EF3-8: External fault																	
OS: Overspeed	ERR: EEPROM writing fault																	
SVE: Zero servo error	CF: Control fault																	
P5-02	connection point act selection at fault restart	0	<p>The act selection of fault output connection point at fault restart.</p> <table border="1"> <thead> <tr> <th>Set value</th> <th>Description</th> </tr> </thead> <tbody> <tr> <td>0</td> <td>The fault connection point will not act at restart</td> </tr> <tr> <td>1</td> <td>The fault connection point will act at restart.</td> </tr> </tbody> </table>	Set value	Description	0	The fault connection point will not act at restart	1	The fault connection point will act at restart.									
Set value	Description																	
0	The fault connection point will not act at restart																	
1	The fault connection point will act at restart.																	

Parameter No.	Name	Set value before leaving factory	Description	Remark												
P6-01	Act selection of overtorque detection	0	Set the overtorque detection function It is judge by output current in V/F control method. It is detected by the overtorque level of the inner torque reference of the inverter in Vector control method.													
			<table border="1"> <thead> <tr> <th>Set value</th> <th>Description</th> </tr> </thead> <tbody> <tr> <td>0</td> <td>Overtorque detection is unavailable</td> </tr> <tr> <td>1</td> <td>Overtorque detection is available. The overtorque detection will be performed in speed arrival. OL3 will flash and the inverter go on run if the overtorque is detected.</td> </tr> <tr> <td>2</td> <td>Overtorque detection is available. The overtorque detection will be performed in run. OL3 will flash and the inverter will go on run if the overtorque is detected.</td> </tr> <tr> <td>3</td> <td>Overtorque detection is available. The overtorque detection will be performed at the speed arrival. OL3 will display the fault connection point act, the inverter block output if the overtorque is detected.</td> </tr> <tr> <td>4</td> <td>Overtorque detection is available The overtorque detection will be performed in run. OL3 will display act of the fault connection point, the inverter will block output if the overtorque is detected.</td> </tr> </tbody> </table>		Set value	Description	0	Overtorque detection is unavailable	1	Overtorque detection is available. The overtorque detection will be performed in speed arrival. OL3 will flash and the inverter go on run if the overtorque is detected.	2	Overtorque detection is available. The overtorque detection will be performed in run. OL3 will flash and the inverter will go on run if the overtorque is detected.	3	Overtorque detection is available. The overtorque detection will be performed at the speed arrival. OL3 will display the fault connection point act, the inverter block output if the overtorque is detected.	4	Overtorque detection is available The overtorque detection will be performed in run. OL3 will display act of the fault connection point, the inverter will block output if the overtorque is detected.
			Set value		Description											
			0		Overtorque detection is unavailable											
			1		Overtorque detection is available. The overtorque detection will be performed in speed arrival. OL3 will flash and the inverter go on run if the overtorque is detected.											
			2		Overtorque detection is available. The overtorque detection will be performed in run. OL3 will flash and the inverter will go on run if the overtorque is detected.											
3	Overtorque detection is available. The overtorque detection will be performed at the speed arrival. OL3 will display the fault connection point act, the inverter block output if the overtorque is detected.															
4	Overtorque detection is available The overtorque detection will be performed in run. OL3 will display act of the fault connection point, the inverter will block output if the overtorque is detected.															
P6-02	Overtorque diction level 1	150	Set overtorque detection level V/F control method: take the rated current of the inverter as 100%. Vector control method: take the rated torque of the motor as 100%.													
P6-03	Overtorque detection time 1	0.1	The overtorque will be detected if the motor current or torque exceeds the set value P6-02 and the time exceeds the set value P6-03; the operator will display OL3.													
P6-04	Act selection of overtorque detection 2	0	P6-04-P6-06 have the same act function with P6-01-P6-03. This function is joint used with multifunction output terminal that is set as " In overtorque detection 2"; the operator will display "OL4" if the overtorque is detected.													
P6-05	Overtorque detection level 2	150														
P6-06	Overtorque detection time 2	0.1														
P7-01	Torque limit of forward run electromotion side	200	Set torque limit value of the forward run electromotion side.													
P7-02	Torque limit of reverse run electromotion side	200	Set torque limit value of the reverse run electromotion side.													
P7-03	Torque limit of forward run regeneration side	200	Set the torque limit value of forward run regeneration side.													
P7-04	Torque limit of reverse run regeneration side	200	Set torque limit value of reverse run regeneration side.													

7.9 O Parameter Group

Parameter No.	Name	Set value before leaving factory	Description	Remark										
P8-01	Protection of the inner brake resistor	0	Select the protection function for the built-in brake resistor of the inverter. <table border="1"> <thead> <tr> <th>Set value</th> <th>Description</th> </tr> </thead> <tbody> <tr> <td>0</td> <td>The overheat protection to brake resistor is unavailable.</td> </tr> <tr> <td>1</td> <td>The overheat protection to brake resistor is available.</td> </tr> </tbody> </table>	Set value	Description	0	The overheat protection to brake resistor is unavailable.	1	The overheat protection to brake resistor is available.					
Set value	Description													
0	The overheat protection to brake resistor is unavailable.													
1	The overheat protection to brake resistor is available.													
P8-02	OH Pre-warning level	95	Set the cooling fin overheat pre-warning temperature											
P8-03	Act selection after OH pre-warning	3	Select the operation method after the overheat pre-warning of cooling fin of the inverter is detected. <table border="1"> <thead> <tr> <th>Set value</th> <th>Description</th> </tr> </thead> <tbody> <tr> <td>0</td> <td>Decelerated stop with set value 31-02</td> </tr> <tr> <td>1</td> <td>Free run</td> </tr> <tr> <td>2</td> <td>Decelerated stop with set value 31-09 (urgent stop).</td> </tr> <tr> <td>3</td> <td>Continue to run</td> </tr> </tbody> </table>	Set value	Description	0	Decelerated stop with set value 31-02	1	Free run	2	Decelerated stop with set value 31-09 (urgent stop).	3	Continue to run	
Set value	Description													
0	Decelerated stop with set value 31-02													
1	Free run													
2	Decelerated stop with set value 31-09 (urgent stop).													
3	Continue to run													
P8-05	Protection selection of phase-absence at the input side	0	If the power source absent phase, or the voltage of the power source is not balance or the electrolytic condenser on the main loop has gone bad, the excessive large ripple voltage on DC bus-bar of the inverter will be detected and the inverter will stop. <table border="1"> <thead> <tr> <th>Set value</th> <th>Description</th> </tr> </thead> <tbody> <tr> <td>0</td> <td>Excessive large ripple voltage detection is unavailable</td> </tr> <tr> <td>1</td> <td>Excessive large ripple voltage detection is available.</td> </tr> </tbody> </table>	Set value	Description	0	Excessive large ripple voltage detection is unavailable	1	Excessive large ripple voltage detection is available.					
Set value	Description													
0	Excessive large ripple voltage detection is unavailable													
1	Excessive large ripple voltage detection is available.													
P8-07	Protection selection of the phase-absence at output side	0	Detection of the output phase-absence if the inverter. <table border="1"> <thead> <tr> <th>Set value</th> <th>Description</th> </tr> </thead> <tbody> <tr> <td>0</td> <td>Output phase-absence detection of the inverter is unavailable.</td> </tr> <tr> <td>1</td> <td>Output phase-absence detection of the inverter is available</td> </tr> </tbody> </table>	Set value	Description	0	Output phase-absence detection of the inverter is unavailable.	1	Output phase-absence detection of the inverter is available					
Set value	Description													
0	Output phase-absence detection of the inverter is unavailable.													
1	Output phase-absence detection of the inverter is available													
O1-01	Monitor selection	0	Replace the M1-04 monitor item; four items in the run can be monitored. It can replace output voltage display. The setting method: set O1-01 replace <input type="checkbox"/> in M1- <input type="checkbox"/> <input type="checkbox"/> .											
O1-02	Selection of monitor items at the power source is brought into use	1	Select the display items after the power source is brought into use. <table border="1"> <thead> <tr> <th>Set value</th> <th>Description</th> </tr> </thead> <tbody> <tr> <td>1</td> <td>Display frequency reference</td> </tr> <tr> <td>2</td> <td>Display output frequency</td> </tr> <tr> <td>3</td> <td>Display output current</td> </tr> <tr> <td>4</td> <td>display the items set by O1-01.</td> </tr> </tbody> </table>	Set value	Description	1	Display frequency reference	2	Display output frequency	3	Display output current	4	display the items set by O1-01.	
Set value	Description													
1	Display frequency reference													
2	Display output frequency													
3	Display output current													
4	display the items set by O1-01.													

Parameter No.	Name	Set value before leaving factory	Description	Remark										
O1-03	The unit of frequency reference/monitor setting	0	<table border="1"> <thead> <tr> <th>Set value</th> <th>Description</th> </tr> </thead> <tbody> <tr> <td>0</td> <td>The unit is 0.01Hz</td> </tr> <tr> <td>1</td> <td>0.01%</td> </tr> <tr> <td>2~39</td> <td>r/min r/min=120×frequency reference (Hz)/01-03 unavailable in OPEN LOOP VECTOR control</td> </tr> <tr> <td>40~39999</td> <td>The position of the radix point is decided by the fifth digit of 01-03. The value of the fifth digit=0:Expressed as ■■■■ The value of the fifth digit=1:Expressed as ■■■、■ The value of the fifth digit=2:Expressed as ■■、■■ The value of the fifth digit=3:Expressed as ■、■■■ The percentage is decided by the fourth-first digit of O1-03. (Example 1) O1-03=12000, 100% speed is expressed as 200.0 60% speed is expressed as 120.0 (Example 2) O1-03=26500, 60% speed is expressed as 39.00.</td> </tr> </tbody> </table>	Set value	Description	0	The unit is 0.01Hz	1	0.01%	2~39	r/min r/min=120×frequency reference (Hz)/01-03 unavailable in OPEN LOOP VECTOR control	40~39999	The position of the radix point is decided by the fifth digit of 01-03. The value of the fifth digit=0:Expressed as ■■■■ The value of the fifth digit=1:Expressed as ■■■、■ The value of the fifth digit=2:Expressed as ■■、■■ The value of the fifth digit=3:Expressed as ■、■■■ The percentage is decided by the fourth-first digit of O1-03. (Example 1) O1-03=12000, 100% speed is expressed as 200.0 60% speed is expressed as 120.0 (Example 2) O1-03=26500, 60% speed is expressed as 39.00.	
			Set value	Description										
			0	The unit is 0.01Hz										
			1	0.01%										
2~39	r/min r/min=120×frequency reference (Hz)/01-03 unavailable in OPEN LOOP VECTOR control													
40~39999	The position of the radix point is decided by the fifth digit of 01-03. The value of the fifth digit=0:Expressed as ■■■■ The value of the fifth digit=1:Expressed as ■■■、■ The value of the fifth digit=2:Expressed as ■■、■■ The value of the fifth digit=3:Expressed as ■、■■■ The percentage is decided by the fourth-first digit of O1-03. (Example 1) O1-03=12000, 100% speed is expressed as 200.0 60% speed is expressed as 120.0 (Example 2) O1-03=26500, 60% speed is expressed as 39.00.													
O1-04	The set unit of parameters	0	The set unit of relative parameters of V/F, 51-04, 06, 07, 09 can be set with the unit of rpm.											
O1-05	Selection of Parameter No. express	0	The express methods selection of the parameter No. on the operator 0: Qma MENU 1: MODBUS ADDRESS											
O2-01	PANEL/FWD key function selection	1	<p>The PANEL/FWD key on the operator is available /unavailable</p> <table border="1"> <thead> <tr> <th>Set value</th> <th>Description</th> </tr> </thead> <tbody> <tr> <td>0</td> <td>The PANEL/FWD key on the operator is unavailable.</td> </tr> <tr> <td>1</td> <td>The PANEL/FWD key on the operator is available.</td> </tr> </tbody> </table>	Set value	Description	0	The PANEL/FWD key on the operator is unavailable.	1	The PANEL/FWD key on the operator is available.					
Set value	Description													
0	The PANEL/FWD key on the operator is unavailable.													
1	The PANEL/FWD key on the operator is available.													
O2-02	STOP key function selection	1	<p>The STOP key is available /unavailable</p> <table border="1"> <thead> <tr> <th>Set value</th> <th>Description</th> </tr> </thead> <tbody> <tr> <td>0</td> <td>STOP key on the operator is unavailable The STOP key on the operator is unavailable to the run references beyond operator.</td> </tr> <tr> <td>1</td> <td>STOP key on the operator is available The STOP key on the operator is available even to the run references beyond operator.</td> </tr> </tbody> </table>	Set value	Description	0	STOP key on the operator is unavailable The STOP key on the operator is unavailable to the run references beyond operator.	1	STOP key on the operator is available The STOP key on the operator is available even to the run references beyond operator.					
Set value	Description													
0	STOP key on the operator is unavailable The STOP key on the operator is unavailable to the run references beyond operator.													
1	STOP key on the operator is available The STOP key on the operator is available even to the run references beyond operator.													

Parameter No.	Name	Set value before leaving factory	Description	Remark						
O2-03	User parameter initial value reset	1	<table border="1"> <thead> <tr> <th>Set value</th> <th>Description</th> </tr> </thead> <tbody> <tr> <td>1</td> <td>Set the user's initial value O2-03=1, hold the user's initial value If the initial changed, 11-03=1110, all parameters return to the use's initial values.</td> </tr> <tr> <td>2</td> <td>Clear away the user's parameters' initial value.</td> </tr> </tbody> </table>	Set value	Description	1	Set the user's initial value O2-03=1, hold the user's initial value If the initial changed, 11-03=1110, all parameters return to the use's initial values.	2	Clear away the user's parameters' initial value.	
			Set value	Description						
			1	Set the user's initial value O2-03=1, hold the user's initial value If the initial changed, 11-03=1110, all parameters return to the use's initial values.						
2	Clear away the user's parameters' initial value.									
<p>The selection that if the ENTER key must be input when setting frequency references with the operator.</p> <table border="1"> <thead> <tr> <th>Set value</th> <th>Description</th> </tr> </thead> <tbody> <tr> <td>0</td> <td><input type="checkbox"/> ENTER key—necessary</td> </tr> <tr> <td>1</td> <td><input type="checkbox"/> ENTER key—unnecessary</td> </tr> </tbody> </table>		Set value	Description	0	<input type="checkbox"/> ENTER key—necessary	1	<input type="checkbox"/> ENTER key—unnecessary			
Set value	Description									
0	<input type="checkbox"/> ENTER key—necessary									
1	<input type="checkbox"/> ENTER key—unnecessary									
<p>The act selection of the inverter when the communication fault between operator and the inverter occurs (The connection wire disconnects or operator is pull out).</p> <table border="1"> <thead> <tr> <th>Set value</th> <th>Description</th> </tr> </thead> <tbody> <tr> <td>0</td> <td>The inverter go on to run</td> </tr> <tr> <td>1</td> <td>The inverter decelerate to stop and display "OPR"</td> </tr> </tbody> </table>		Set value	Description	0	The inverter go on to run	1	The inverter decelerate to stop and display "OPR"			
Set value	Description									
0	The inverter go on to run									
1	The inverter decelerate to stop and display "OPR"									
O2-05	The method selection to set frequency reference	0								
O2-06	Act selection when the operator disconnects.	0								
O2-07	Setting of elapsed time	-	Elapsed time, the initial set elapsed time is from this set value.							
O2-08	Selection of elapsed time	0	<table border="1"> <thead> <tr> <th>Set value</th> <th>Description</th> </tr> </thead> <tbody> <tr> <td>0</td> <td>Accumulate working time when the power source is connected.</td> </tr> <tr> <td>1</td> <td>Accumulate working time when the inverter start to run.</td> </tr> </tbody> </table>	Set value	Description	0	Accumulate working time when the power source is connected.	1	Accumulate working time when the inverter start to run.	
			Set value	Description						
			0	Accumulate working time when the power source is connected.						
1	Accumulate working time when the inverter start to run.									

7.91 Set Value List of Multifunction Input/Output Terminals

☆☆ Available when the T3-09=1F.

Set value	Function of multifunction input terminal (T1-01, 02, 03, 04, 05, 06)	Function of multifunction input terminal (T2-01, 02, 03)	Function of the multifunction analog input terminal (T3-05)
00	3-wire control method	In run	Auxiliary frequency reference
01	PANEL/FWD Selection	Zero speed	PGAIN
02	OPTION card/Inverter switch	Frequency arrival	FBIS
03	Multi-section speed reference 1	Any frequency arrival	Not be used
04	Multi-section speed reference 2	Frequency detection 1	VBIAS
05	Multi-section speed reference 3	Frequency detection 2	Accel/decel time compression coefficient
06	Inching reference	Inverter preparation is completed.	DC brake current
07	Accel/decel time selection	In undervoltage detection	Overtorque detection level
08	External B.B (Connection A)	In B.B (Connection A)	Level of speed loss in run
09	External B.B (Connection A)	Frequency reference method	Level of frequency reference lower limit
0A	Accel/decel stop	Run reference method	Number of the forbidden frequencies
0B	Alarm on overheat of the inverter(OH2)	In over torque detection	PID feedback
0C	Multifunction analog is available/unavailable	In frequency reference loss	Not be used
0D	Speed control canceling	Brake resistor fault	
0E	Reset of speed control integral	Fault	
0F	Not be used	Not be used	
10	Speed up connection point (UP)	Alarm	Forward run torque limit
11	Speed down connection point (Down)	In Fault reset	Reverse run torque limit
12	Forward inching reference	Timer	Regeneration torque limit
13	Reverse inching reference	Frequency arrival 2	Torque reference, control, torque limit, speed control.
14	Fault reset	Any frequency arrival 2	Torque compensation
15	Urgent stop	Frequency detection 3	In forward/reverse run torque limit
16	Not be used	Frequency detection 4	Nor be used
17	Not be used	In overtorque detection 1 (Connection point b)	
18	Timer	In overtorque detection 2 (Connection point a)	
19	PID control cancel	In overtorque detection 2 (connection point b)	
1A	Accel/decel time selection 2	In reverse run	
1B	Parameter writing forbidding	In B.B (Connection b)	Not be used
1C	+SPEED reference	Not be used	
1D	-SPEED	Electrical motor /generator method	
1E	Analog input	Fault restart	
1F	Analog input terminal selection	OH1 pre-warning	
20	External fault	OH pre-warning	

Set value	Function of multifunction input terminal (T1-01, 02, 03, 04, 05, 06)	Function of multifunction input terminal (T2-01, 02, 03)	Function of the multifunction analog input terminal (T3-05)	
21-2F		Not be used	Not be used	
30	Not be used	In torque limit		
31	Not be used	Speed limit		
32		Not be used		
33		Zero servo completed		
37		In run 2		
34-5F				
60		DC brake reference		
61	External speed search reference 1			
62	External speed search reference			
63	Energy save run			
64	External speed search reference			
65	Decelerating run reference at transient pause (Connection point A)			
66	Decelerating run reference at transient pause (Connection point B)			
67-70	Not be used			
71	Speed control/torque control switch			
72	Zero servo reference			
73-76	Not be used			
77	Speed control proportional gain			
78-FF	Not be used			

7.92 Set Values before Leaving Factory
440V grade

Parameter	Name	Unit	Set value before leaving factory															
			3	5	5 ^{1/2}	7 ^{1/2}	10	15	20	25	30	40	50	60	75	100	150	200
-	Power capacity of the inverter	HP	3	5	5 ^{1/2}	7 ^{1/2}	10	15	20	25	30	40	50	60	75	100	150	200
	Inverter capacity	KW	22	3.7	4	5.5	7.5	11	15	18.5	22	30	37	45	55	75	110	160
02-04	Selection of Inverter capacity AC440V	1	23	24	25	26	27	28	29	2A	2B	2C	2D	2E	2F	30	32	34
		HP	3	5	5 ^{1/2}	7 ^{1/2}	10	15	20	25	30	40	50	60	75	100	150	200
36-01	Upper limit of carrier frequency	KHz	15.0	150	15.0	150	15.0	15.0	15.0	15.0	15.0	15.0	10.0	10.0	10.0	10.0	100	2.0
36-02	Lower limit of carrier frequency	KHz	15.0	150	15.0	150	15.0	15.0	15.0	15.0	15.0	15.0	10.0	10.0	10.0	10.0	100	2.0
36-03	Proportional gain of carrier frequency	1	0	0	0	0	0	0	0	0	0	0	0	0	0	0	0	0
52-01	Rated current of the motor	A	4.20	7.00	7.00	9.80	13.3	19.9	26.5	32.9	38.6	52.3	65.6	79.7	95.0	130	190	270
52-02	Rated slip of the motor	Hz	3.00	2.70	2.70	150	1.30	1.70	1.60	1.67	1.70	1.80	1.33	1.60	1.46	1.39	1.40	1.35
52-03	No-load current of the motor	A	1.50	230	2.30	260	4.00	5.6	7.6	7.8	9.2	10.9	19.1	22.0	24.0	36.0	490	70.0
52-05	TLT impedance		6.495	3333	3333	1.595	1.152	0.922	0.550	0.403	0.316	0.269	0.155	0.122	0.088	0.092	0.046	0.029
52-06	Leak inductance of the motor	%	18.7	193	19.3	182	15.5	19.6	17.2	20.1	23.5	20.7	18.8	19.9	20.0	20.0	200	20.0
P2-02	Transient compensation time	Sec	1.0	20	2.0	20	20	2.0	2.0	2.0	2.0	2.0	2.0	2.0	2.0	2.0	20	2.0
P2-03	Min B.B time	Sec	0.5	05	0.7	07	07	0.7	0.7	1.0	1.0	1.0	1.0	1.0	1.0	1.0	20	2.0
P2-04	Voltage reset time	Sec	0.3	03	0.3	03	03	0.3	0.3	0.6	0.6	0.6	0.6	0.6	0.6	0.6	06	0.6

7.93 The List of Specification Parameter

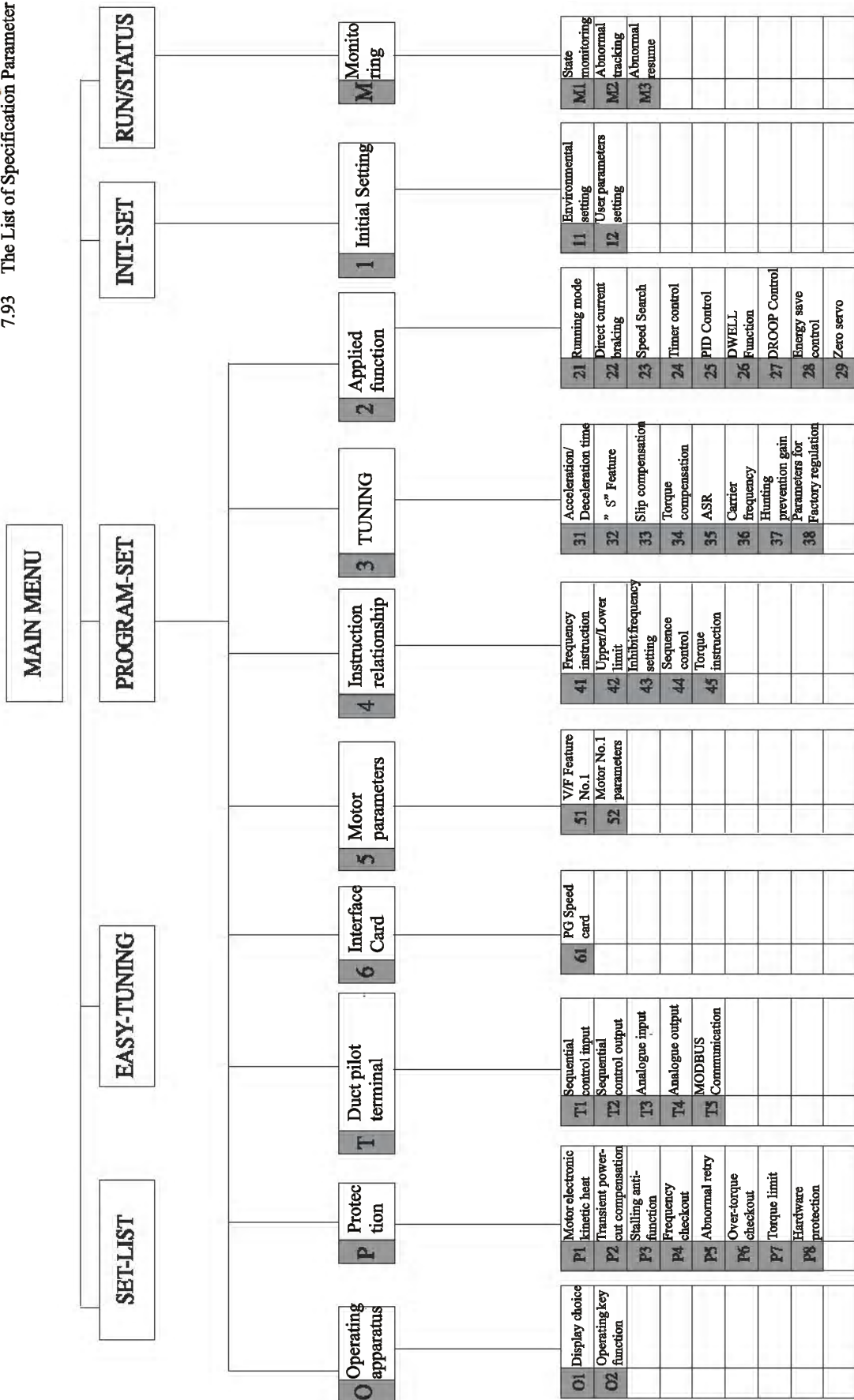

7.94 The List of Simple Parameters

Function	Parameters	Name	Setting Range	Min Setting Unit	Factory Setting Value	Reference Column	Changeable or not in Running		
Environmental Setting	11-00	FACTORYID	Factory ID.			Factory ID.			
	11-01	ACCESSLEVEL	Parameter Access	0-4	1	4	0: Special use for monitoring 1: User Selection 2: quick start 3: Basic level 4: Advanced level	Yes	
	11-02	CONTROLMETHOD	Control Method Selection	0-3	1	2	0: V/F control: V/F control including PG 2: Vector control not including PG 3: Vector control including PG	No	
	11-03	DATAINITIAL (INITPARAMETERS)	Initial Data Reset	0000-9999	1	0000	1110:user parameter reset 2220: two-wire reset 3330:three-wire reset	No	
	11-04	USER PASSWORD	Password 1	0000-9999	1	0000	Write password	No	
	11-05	PROTECT PASSWORD	Password 2	0000-9999	1	0000	Set password will appear after pushing the two keys (> & PRG) at the same time under the state of 11-04	No	
	12-01~12-32	USER PAPAM ITO32	User Selection	-	-	-		No	
Applied Parameters	Operating mode selection	21-01	REFERENCE SOURCE	Frequency instruction selection	0-3	1	1	0: digit operating apparatus 1: Duct pilot terminal 2: Transmission 3: OPTION PCB	No
		21-02	RUN SOURCE	Running instruction selection	0-3	1	1	0: digit operating apparatus 1: Duct pilot terminal 2: Transmission 3: OPTION PCB	No
		21-03	STOPPING METHOD	Stopping method selection	0-3	1	0	0: deceleration stop 1: free stop 2: stop after direct current braking 3:free stop with timing function	No
		21-04	REVERSE OPER	Reverse inhibit selection	0,1		0	0: Reversible 1: Irreversible	No
		21-05	ZERO-SPEED OPER	Running selection under minimum frequency	0-3	1	0	0: usual running 1: output break (B.B) 2: running under minimum frequency 3: Running with zero-speed	No
		21-06	CNTL INPUT SCANS	Time selection for control terminal scanning twice	0,1	1	1	0: 2msec. 1: 5msec.	No
		21-07	PANEL/FWD RUN CYCLE EXTRN RUN	Running selection after running cycle	0,1	1	0		No
	Direct current braking	22-01	DCLNJ START FREQ	Zero-speed benchmark	0.0~10.0	0.1HZ	0.5		No
		22-02	DCLNJ CURRENT	Direct current braking current	0~100	1%	50		No
		22-03	DCLNJ TIME@START	Direct current braking time at start	0.00~10.0	0.01sec	0.00		No
		22-04	DCLNJ TIME@STOP	Direct current braking time at stop	0.00~10.0	0.01sec	0.50		No

Function	Parameters	Name	Setting Range	Min Setting Unit	Factory Setting Value	Reference Column	Changeable or not in Running		
Applied Parameter	Speed search	23-01	SPDSRCH AT START	Speed search selection at start	0,1	1	0	0: Excluded speed search at start 1: Included speed search at start	No
		23-02	SPDSRCH CURRENT	Speed search current	0~200	1%	100		No
		23-03	SPDSRCH DEC TIME	Speed search deceleration time	0.110.0	0.01sec	2.0		No
	Timer function	24-01	DELAY-ON TIMER	On delay time	0.0~300.0	0.01sec	0.0		No
		24-02	DELAY-OFF TIMER	Off delay time	0.0~300.0	0.01sec	0.0		No
	PID Control	25-01	PID MODE	PID Control mode selection	0,1,2,3,4	0	0	0: PID ineffective3: Effective deviation D 1: PID effective4: Effective feedback D 2: PID effective	No
		25-02	PID GAIN	PID Proportional gain(P)	0.00~10.00	0.01	1.00		Yes
		25-03	PID I TIME	Integration time(I)	0.00~360.0	0.01sec	1.0		Yes
		25-04	PID I LIMIT	Integration(I) upper limit	0.00~100.0	0.1%	0.00		Yes
		25-05	PID D TIME	Differentiating time(D)	0.00~10.00	0.01sec	0.00		Yes
		25-06	PID LIMIT	PID Upper limit	0.00~100.0	0.1%	100.0		Yes
		25-07	PID OFFSET	PID Slippage offset	-100.0~100.0	0.1%	0.00		Yes
		25-08	PID DELAY TIME	PID Primary delay time	0.00~100.0	0.01sec	0.00		Yes
	Dwell Function	26-01	DWELL REF@START	Dwell frequency at start	0.0~400.0	0.1HZ	0.0		No
		26-02	DWELL TIME@START	Dwell time at start	0.0~10.0	0.1sec	0.0		No
		26-03	DWELLREF@STOP	Dwell frequency at stop	0.0~400.0	0.1HZ	0.0		No
		26-04	DWELLTIME@STOP	Dwell time at stop	0.0~400.0	0.1sec	0.0		No
	Droop Control	27-01	DROOPQUANTITY	Droop control proportional gain(P)	0.00~1.00	0.01	0.0		Yes
		27-02	DROOPDELAYTIME	Droop control delay time	0.03~2.00	0.01sec	0.05		Yes
	Energy Save control	28-01	ENERGYSAVEGAIN	Energy save gain	0~100	1%	0		No
28-02		ENERGYSAVEFREQ	Energy save frequency	0.0~400.0	0.1HZ	0.0		No	

Function	Parameters	Name	Setting Range	Min Setting Unit	Factory Setting Value	Reference Column	Chang cable or not in Running		
Applied Parameter	Zero servo	29-01	ZEROSERVOGAIN	Zero servo gain	0-100	1	5		No
		29-02	ZEROSERVOCOCUT	Zero servo count	0-16383	1	10		No
TUNING	Acceleration/Deceleration time	31-01	ACCEL TIME1	Acceleration time 1	0.00~6000.0	0.1sec	10		Yes
		31-02	ACCEL TIME1	Deceleration time 1	0.00~6000.0	0.1sec	10		Yes
		31-03	ACCEL TIME2	Acceleration time 2	0.00~6000.0	0.1sec	10		Yes
		31-04	ACCEL TIME2	Deceleration time 2	0.00~6000.0	0.1sec	10		Yes
		31-05	ACCEL TIME3	Acceleration time3	0.00~6000.0	0.1sec	10		No
		31-06	ACCEL TIME3	Deceleration time 3	0.00~6000.0	0.1sec	10		No
		31-07	ACCEL TIME4	Acceleration time 4	0.00~6000.0	0.1sec	10		No
		31-08	ACCEL TIME4	Deceleration time 4	0.00~6000.0	0.1sec	10		No
		31-09	FASTSTOPTIME	Emergent stop time	0.00~6000.0	0.1sec	10		No
		31-10	ACC/DEC UNIST	Acceleration/Deceleration time unit	0.1	1	1	0: 0.1 second as unit of acceleration/ deceleration time 1: 0.01 second as unit of acceleration/ deceleration time	No
		31-11	ACC/DEC SWFREQ	Acceleration/Deceleration time switching frequency	0.0~400.0	0.1HZ	0.0		No
TUNING	Operating mode selection	32-01	SCRV ACC@START	"S" characteristic time at the beginning of acceleration	0.00~2.5	0.00sec	0.20		No
		32-02	SCRV ACC@END	"S" characteristic time at the end of acceleration	0.00~2.5	0.00sec	0.20		No
		32-03	SCRV ACC@START	"S" characteristic time at the beginning of deceleration time	0.00~2.5	0.00sec	0.20		No
		32-04	SCRV ACC @END	"S" characteristic time at the end of deceleration	0.00~2.5	0.00sec	0.20		No
TUNING		33-01	SLIP COMP GAIN	Slip compensation gain	0.00~2.5	0.01	1.0		Yes
		33-02	SLIP COMP TIME	Slip compensation primary delay time	0~1000	1ms	200		No
		33-03	SLIP COMP LIMIT	Slip compensation limit	0~250	1%	200		No
		33-04	SLIP COMP REGEN	Slip compensation in regeneration	0.1	1	0	0: Excluded slip compensation in regeneration 1: Included slip compensation in regeneration	No
TUNING	Speed search	34-01	TORQ COMP GAIN	Torque compensation gain	0.00-2.5	0.01	1.00		Yes
		34-02	TORQ COMP TIME	Torque compensation time	0~100	0msec	20		No

Function	Parameters	Name	Setting Range	Min Setting Unit	Factory Setting Value	Reference Column	Changeable or not in Running			
TUNING	ASR	35-01	ASR PGAIN1	ASF Proportional gain 1	0.0~300.0	0.01	20.00		Yes	
		35-02	ASR ITIME1	ASF Integration time 1	0.000~10.000	0.001sec	0.500		Yes	
		35-03	ASRP GAIN2	ASF Proportional gain 2	0.00~300.0	0.01	20.00		Yes	
		35-04	ASR ITIME2	ASF Integration time 2	0.000~10.000	0.001sec	0.500		Yes	
		35-05	ASR LIMIT	ASF limit	0.0~20.0	0.1%	5.0		No	
		35-06	ASR DELAY TIME	ASF output delay time	0.000~0.500	0.001sec	0.004		No	
		35-07	ASRGAIN SWFREQ	ASF switch frequency	0.0~400.0	001HZ	0.0		No	
	Carrier Frequency	36-01	CARRIER FREQ MAX	Carrier frequency max.	0.4~15.0	0.1KHZ	15.0	Setting range of 36-01~02 is 2.0~15.0 with vector including PG	No	
		36-02	CARRIER FREQ MIN	Carrier frequency min.	0.4~15.0	0.1KHZ	15.0		No	
		36-03	CARRIER FREQ GAIN	Carrier frequencyproportional gain	00~99	1	00		No	
	Hunting Prevention	37-01	HNUTPREV SELECT	Hunting prevention function selection	0.1	0	1	0: Hunting prevention function is effective 1: Hunting prevention function is ineffective	No	
		37-02	HNUTPREV GAIN	Hunting prevention gain	0.00~2.5	0.01	1.00		No	
	AFR	38-08	AFR GAIN	AFR gain	0.00~10.00	0.01	1.00		No	
		38-09	AFR TIME	AFR time constant	0~1000	1msec	50		Yes	
		38-30	CURRIER IN TUNE	Carrier frequency in tuning	0,1,2	0	2	0: Carrier 2KHZ 1: Carrier set value as 36-01 2: Carrier 5KHZ	Yes	
	Instruction Relationship	Frequency Instruction Value	41-01	REFERENCE1	Frequency Instruction 1	0.0~400.00	0.1HZ	0.00		Yes
			41-02	REFERENCE2	Frequency Instruction 2	0.0~400.00	0.1HZ	0.00		Yes
			41-03	REFERENCE3	Frequency Instruction 3	0.0~400.00	0.1HZ	0.00		Yes
			41-04	REFERENCE4	Frequency Instruction 4	0.0~400.00	0.1HZ	0.00		Yes
			41-05	REFERENCE5	Frequency Instruction 5	0.0~400.00	0.1HZ	0.00		Yes
			41-06	REFERENCE6	Frequency Instruction 6	0.0~400.00	0.1HZ	0.00		Yes
41-07			REFERENCE7	Frequency Instruction 7	0.0~400.00	0.1HZ	0.00		Yes	
41-08			REFERENCE8	Frequency Instruction 8	0.0~400.00	0.1HZ	0.00		Yes	
41-09			JOG REFERENCE	Jogging frequency	0.0~400.00	0.1HZ	6.00		Yes	
Frequency Limit		42-01	REF UPPER LIMIT	Frequency Instructionupper limit	0.00~110.0	100.0%	100%		No	
		42-02	REE LOWER LIMIT	Frequency Instructionlower limit	0.0~100.0	0.0%	0.0%		No	
Inhibiting Limit		43-01	JUMPFREQ1	Jump frequency 1	0.0~400.00	0.1HZ	0.0		No	
		43-02	JUMPFREQ2	Jump frequency 2	0.0~400.00	0.1HZ	0.0		No	
Frequency Setting		43-03	JUMPFREQ3	Jump frequency 3	0.0~400.00	0.1HZ	0.0		No	
		43-04	JUMP BANDWIDTH	Jump frequencybandwidth	0.0~400.00	0.1HZ	0.0		No	
Sequence control		44-01	MOP REF MEMORY	Frequency Instruction remain function selection	0,1	0	0	0:Frequency Instruction without memory 1:Frequency Instruction with memory	No	
		44-02	TRIM CONTROLVL	+/speed control	1~100	1%	20		No	

Function	Parameters		Name	Setting Range	Min Setting Unit	Factory Setting Value	Reference Column	Changeable or not in Running	
MotorParameters	Torque Instruction	45-01	TORQ CONTROL SEL	Torque control selection	0.1	0	0	0: Speed control 1: Torque control	No
		45-02	TORQUE REF FILTER	Torque instruction delay time	0~1000	0ms	0	1: Analogic signal 2: Modality setting	No
		45-03	SPEED LIMIT SEL	Speed limit selection	1,2	1	1		No
		45-04	SPEED LMT VALUE	Speed limit	-120~+120	1%	0		No
		45-05	SPEED LMT BIAS	Speed limit bias voltage	0~120	1%	10		No
		45-06	REF HOLD TIME	Speed/torque control switching time	0~1000	0ms	0		No
	V/F Feature	51-01	INPUT VOLTAGE	Input voltage	155~255	IV	200		No
		51-02	MOTOR SELECTION	Motor selection	0,1,2	0	0	0: Standard motor1: Vector motor2: Special motor	No
		51-03	V/F SELECTION	V/F curve selection	0-F	0	F	0-E: 15 kinds of stable curves F: Arbitrary curve	No
		51-04	MAX FREQUENCY	Max. output frequency	50.0~400.0	0.1HZ	60.0		No
		51-05	MAX VOLTAGE	Max. voltage	0.0~255.0	0.1V	200.0		No
		51-06	BASE FREQUENCY	Max. voltage frequency	0.0~400.0	0.1HZ	60.0		No
		51-07	MID FREQUENCYA	Middle output frequency	0.0~400.0	0.1HZ	3.0	Variation with different 11-02 setting	No
51-08		MID VOLTAGEA	Middle output frequency voltage	0.0~255.0	0.1V	11.0	Variation with different 11-02 setting	No	
51-09		MIN FREQUENCY	Min. output frequency	0.0~400.0	0.1HZ	0.5	Variation with different 11-02 setting	No	
51-10		MIN VOLTAGE	Min. output frequency Voltage	0.0~255.0	0.1V	2.0	Variation with different 11-02 setting	No	
51-11		MIN FREQUENCYB	Middle output frequency B	0.0~400.0	0.1HZ	0.0		No	
51-12		MID VOLTAGEB	Middle output frequency voltage B	0.0~255.0	0.1V	0.0		No	
51-13	BASE VOLIAGE	Base voltage	0.01~255.0	0.1V	0.0		No		
MotorParameters	52-01	MOTOR RATED FLA	Motor rated current	0.01~1500.0	0.1A	1.90	With different volume, factory setting value is different	No	
	52-02	MOTOR RATED SLIP	Motor rated slip	0.00~20.00	0.01HZ	2.9	With different volume, factory setting value is different	No	
	52-03	NO-LOAD CURRENT	Motor no-load current	0.00~1500.00	0.01A	1.20	With different volume, factory setting value is different	No	
	52-04	NUMBER OF POLES	Motor number of poles	2~48	1pole	4	With different volume, factory setting value is different	No	
	52-05	TERMRESISTANCE	Motor winding resistance	0.00~65.00	0.001	9.842	With different volume, factory setting value is different	No	
	52-06	LEAK INDUCTANCE	Motor leak inductance	0.0~30.0	0.1%	18.2	With different volume, factory setting value is different	No	
	52-07	SATURATION COMP1	Motor iron-core saturation coefficient 1	0.00~0.50	0.01	0.5	With different volume, factory setting value is different	No	
	52-08	SATURATION COMP2	Motor iron-core saturation coefficient 2	0.00~0.75	0.01	0.75	With different volume, factory setting value is different	No	
	52-09	MECHANICALLOSS	Motor mechanical loss	0.0~10.0	0.1%	0.0	With different volume, factory setting value is different	No	
Motor No.2Parameters	53-01	COLTROL METHOD	Motor 2 control mode selection	0~3	1	2	0: V/F control1: V/F control with PG2: Vector control without PG3: Vector control with PG	No	

Function	Parameters	Name	Setting Range	Min Setting Unit	Factory Setting Value	Reference Column	Changeable or not in Running		
MotorParameters	V/F Feature 2	54-01	MAX FREQUENCY	Motor No.2 max. output frequency	50.0~400.0	0.1HZ	60.0		
		54-02	MAX VOLTAGE	Motor No.2 max. voltage	0.0~255.0	0.1V	200.0		
		54-03	BASE FREQUENCY	Motor No.2 max. voltage frequency	0.0~400.0	0.1HZ	60.0		
		54-04	MID FREQUFNCY	Motor No.2 mid. output frequency	0.0~400.0	0.1HZ	3.0	Variation with different 11-03 setting	
		54-05	MID VOLTAGE	Motor No.2 mid. output voltage	0.0~255.0	0.1V	10.0	Variation with different 11-03 setting	
		54-06	MIN FREQUENCY	Motor No.2 Min. output frequency	0.0~400.0	0.1HZ	0.5	Variation with different 11-03 setting	
		54-07	MIN VOLTAGE	Motor No.2 Min. output voltage	0.0~255.0	0.1V	1.7	Variation with different 11-03 setting	
	Motor No.2Parameters	55-01	MOTOR RETED FLA	Motor No.2 rated current	0.00~1500.0	0.1A	1.90		
		55-02	MOTOR RATED SLTP	Motor No.2 rated slip	0.00~20.00	0.01HZ	2.90		
		55-03	NO-LOAD-CURRENT	Motor No.2 no-load current	0.00~1500.0	0.01A	1.20		
		55-04	MOTOR2#POLES	Motor No.2 number of poles	2~48	1pole	4		
		55-05	TERM RESISTANCE	Motor No.2 winding resistance	0.000~65.000	0.001	9.842		
		55-06	LEAK INOUCTANCE	Motor No.2 leak inductance	0.0~30.0	0.1%	18.2		
	Interface Card	PG Card	61-01	PG PULSES/REV	PG pulse number	0~6000	1	600	
			61-02	PG FDBK LOSS SEL	PG feedback loss selection	0~3	1	1	0: Deceleration stop 1: free stop 2: emergent stop 3: continuous running
			61-03	PG OVERSPEED SEL	PG over speed selection	0~3	1	1	0: Deceleration stop 1: free stop 2: emergent stop 3: continuous running
61-04			PG DEVIATION SEL	PG over deviation selection	0~3	1	3	0: Deceleration stop 1: free stop 2: emergent stop 3: continuous running	
61-05			PG ROTATION SEL	PG rotation selection	0.1	1	0	0: Motor forward rotation C.C.W 1: Motor reverse rotation C.W	
61-06			PG OUTPUT RAITO	PG output ratio	1~32	1	1	PG-B2 Card is effective	
61-07			PG RAMP PL/1 SEL	Integral control selection in acceleration/ deceleration	0.1	1	0	0: Integral control is ineffective 1: Integral control is effective	
61-08			PG OVERSPD LEVEL	Over speed checkout level	1~120	1%	115		
61-09			PG OVERSPD TIME	Over speed checkout delay time	0.0~2.0	0.1sec	0.0		
61-10			PG DEVIATE LEVEL	Over speed deviation checkout level	0~50	1%	10		
61-11			PG DEVIATE TIME	Over speed deviation checkout delay time	0.0~10.0	0.1sec	0.5		
61-12			PG#GEAR TEETH1	PG gear teeth 1	0~1000	1	0		
61-13			PG#GEAR TEETH2	PG gear teeth 2	0~1000	1	0		
61-14			PGO DETECTION	PGO checkout time	0.0~10.0	0.1sec	2.0		

Function	Parameters	Name	Setting Range	Min Setting Unit	Factory Setting Value	Reference Column	Chang cable or not in Running		
Function New Additional Function	PID Control	21-08	RUN CMD AI PRG	Run interlocking at program schema	0.1	0	0	0: Non-performable1: performable	No
		21-08	FIELD COMP	Magnetic flux compensation	0~500%	1%	0	No-loaded current as 100% unit	No
		25-09	OUTPUT LEVEL SEL	PID Output positive/negative feature	0,1	0	0	0: Positive feature 1:Negative feature	No
		25-10	OUTPUT GAINL SEL	PID Output gain	0.0~25.0	0.0	1.0		No
		25-11	OUTPUT REV SEL	PID Output reverse	0,1	0	0	0: As zero limit1: Reverse rotation	No
		25-12	FB LOS DET SEL	PID Feedback loss detection	0,1,2	0	0	0: ineffective1: effective	No
		25-13	FB LOS DET LVL	PID Feedback loss level	0~150	0	0	Output frequency as 100% unit	No
		25-14	FB LOS DET TIME	PID Feedback loss time	0.0~25.0	0.0sec	1.0	Second as unit of feedback loss detection	No
	Slip	33-05	FLUX SELECT	Magnetic flux calculation selection	0,1	0	0	0: After compensation1: Before compensation	
		33-06	OUTPUT LIMIT	Output Voltage saturated Magnetic flux	0,1	0	0	0: ineffective1: effective	
		Torque Compensation	34-03	F TORQCOMP@START	100% setting for positive torque	0.00~200.0	0	0	
	34-04		F TORQCOMP@START	100% setting for negative torque	0.00~200.0	0	0		
	34-05		TORQCOMP DELAYT	Pull-in torque rise time	0~200	0ms	10	millisecond unit	
	ASR	35-08	ASR I LIMIT	ASR Integral upper limit	0~400	0	400	Normal load 100% unit	
	Parameters	52-10	TCDMP LRON LOSE	"W" as unit of Electric engine, iron loss	0~6553.5	0	14		
Duct Pilot Terminal Function	Sequence Input	T1-01	TERM EF SELECT	Terminal EF function selection	00~FF	1	24		No
		T1-02	TERM RST SELECT	Terminal RST function selection	00~FF	1	14		No
		T1-03	TERM MS1 SELECT	Terminal MS1 function selection	00~FF	1	3		No
		T1-04	TERM MS2 SELECT	Terminal MS2 function selection	00~FF	1	4		No
		T1-05	TERM JOG SELECT	Terminal JOG function selection	00~FF	1	6		No
		T1-06	TERM BX SELECT	Terminal BX function selection	00~FF	1	8		No
	Sequence Output	T2-01	TERM RA SELECT	Terminal RA-RC function selection	00~FF	1	0		No
		T2-02	TERM Y1 SELECT	Terminal Y1 function selection	00~FF	1	1		No
		T2-03	TERM Y2SELECT	Terminal Y2 function selection	00~FF	1	2		No
	Analog Input	T3-01	TERM FIV SIGNAL	Terminal FIV signal level	0,1	0	0	0: 0~+10V input 1: -10V~+10V input	No
		T3-02	TERM FIV GAIN	Terminal FIV input gain	0.0~1000.0	0.1%	100.0		Yes
		T3-03	TERM FIV BIAS	Terminal FIV input bias voltage	-100.0~+100.0	0.1%	0.0		Yes
		T3-04	TERM MFI SIGNAL	Terminal MFI signal level	0,1	1	0	0: 0~+10V input 1: -10V~+10V input	No
		T3-05	TERM MFISELECT	Terminal MFI function selection	0~1F	1	0		No

Function	Parameters		Name	Setting Range	Min Setting Unit	Factory Setting Value	Reference Column	Changeable or not in Running	
Duct Pilot Terminal Function	Analog Input	T3-06	TERM MFI GIN	Terminal MFI input gain	0.0~100.0	0.1%	100.0		Yes
		T3-07	TERM MFI BIAS	Terminal MFI input bias voltage	-100.0~+100.0	0.1%	0.0		Yes
		T3-08	TERM FIC SIGNAL	Terminal FIC signal level	0,1,2	1	2	0: 0~+10V 1: -10V~+10V 2: 4~20mA	No
		T3-09	TERM FIC SLECT	Terminal FIC function selection	0~1F	1	1F		No
		T3-10	TERM FIC GAIN	Terminal FIC input gain	0.0~1000.0	0.1%	100.0		Yes
		T3-11	TERM FIC BIAS	Terminal FIC input bias voltage	-100.0~+100.0	0.1%	0.0		Yes
	T3-12	FILTER AVG TIME	Filtering constant of analog input	0.00~2.00	0.01sec	0.00		No	
	Analog Output	T4-01	TERM MV+SEL	Terminal MV+ monitor selection	1~31	1	2		No
		T4-02	TERM MV+ GAIN	Terminal MV+ output gain	0.0~2.50	0.01	1.00		Yes
		T4-03	TERM MV+BIAS	Terminal MV+ output bias voltage	-10.0~10.0	0.0%	0.0		Yes
		T4-04	TERM MV+SEL	Terminal MA+ monitor selection	1~31	1	3		No
		T4-05	TERM MV+GAIN	Terminal MA+ output gain	0.0~2.50	0.01	0.50		Yes
T4-06		TERM MV + BIAS	Terminal MA+ output bias voltage	-10.0~10.0	0.1%	0.0		Yes	
T4-07		AO LEVEL SELECT	Analog output signal level selection	0,1	1	0	0: 0~+10V 1: -10V~+10V	No	
MODBUS Communication	T5-01	SERIAL COMM.ADR	Address setting as MODBUS communication	0~1F	1	1F		No	
	T5-02	SERIAL BAUD RATE	Transmitting rate selection	0~3	1	3	0: 1200BPS 1: 2400BPS2: 4800BPS 3: 9600BPS	No	
	T5-03	SERIAL COM SEL	Transmitting parity selection	0,1,2	1	0	0: No parity 1: Even parity 2: Odd parity	No	
	T5-04	SERIAL FAULT SEL	Transferring abnormal checkout selection	0~3	1	3	0: Deceleration stop 1: free stop 2: emergent stop 3: continuous running	No	
Protection Function	Motor Protection	P1-01	MOL FAULT SELECT	Motor protection selection	0,1	1	1	0: Motor protection ineffective 1: Motor protection effective	No
		P1-02	MOL TIME CONST	Motor protection time	0.1~5.0	0.1min	1.0		No
Transient Power-cut Compensation	Transient Power-cut Compensation	P2-01	PWRL SELECTION	Response selection as transient power-cut	0,1,2	1	0	0: Transient power-cut, i.e. error 1: Continuous work within transient power-cut time 2: CPU-RUN=Enabled	No
		P2-02	PWRL RIDEHRUT	Transient compensation time	0.0~2.0	0.1sec	0.7*2	*2 With different volume, factory setting value is different	No
		P2-03	PWRL BASEBLOCK T	Minimum time	0.0~5.0	0.1sec	0.5*2	*2 With different volume, factory setting value is different	No
		P2-04	PWRL V/F KAMPT	Voltage reset time	0.0~2.0	0.1sec	0.3*2	*2 With different volume, factory setting value is different	No

Function	Parameters		Name	Setting Range	Min Setting Unit	Factory Setting Value	Reference Column	Changeable or not in Running	
Protection Function	Transient Power-cut Compensation	P2-05	PUV DET LEVEL	Low voltage detection level	150~210	1V	160*3	*3: The setting value of 440V grade is twice of that of 220V grade	No
		P2-06	KEB FREQUENCY	KEB deceleration rate	0.0~100.0	0.1	0.0		No
	Stalling anti-function	P3-01	STALLP ACCEL SEL	Stalling anti-function selection in acceleration	0,1,2	0.1	1	0: Stalling anti-function is ineffective 1: Stalling anti-function is effective	No
		P3-02	STALLP ACCEL LVL	Stalling anti-function level in acceleration	0~200	1%	150		No
		P3-03	STALLP CHP LVL	Stalling anti-function level limit in acceleration	0~100	1%	100*4	*4: Factory setting value varies with different 11-02 setting	No
		P3-04	STALLP DECEL SEL	Stalling anti-function selection in deceleration	0,1,2	1	1	0: Stalling anti-function is ineffective 1: Stalling anti-function is effective	No
		P3-05	STALLPRUN SEL	Stalling anti-function selection in running	0,1,2	1	1	0: Stalling anti-function is ineffective 1: Stalling anti-function is effective(31-02) 2: Stalling anti-function is effective(31-04)	No
		P3-06	STALLP RUN LEVEL	Stalling anti-function level in running	30~200	1%	160		No
	Frequency checkout	P4-01	SPD AGREE LEVEL	Frequency checkout level	0.0~400.0	0.1HZ	0.0		No
		P4-02	SPD AGREE WIDTH	Frequency checkout bandwidth	0.0~20.0	0.1HZ	2.0		No
		P4-03	SPD AGREELVL +-	Frequency checkout level (+)	0.0~±400.0	0.1HZ	0.0		No
		P4-04	SPD AGREE WIDTH +-	Frequency checkout bandwidth(+)	0.0~20.0	0.1HZ	2.0		No
		P4-05	REF LOSS SEL	Action selection in frequency instruction loss	0,1	1	0	0: Stop 1: 80% of running speed is lost	No
	Over-torque checkout	P5-01	NUM OF RESTARTS	Number of restart for abnormal reset	0~10	1	0		No
		P5-02	RESTART SEL	Contact selection in restart for abnormal reset	0,1	1	0	0: Abnormal contact point does not work 1: Abnormal contact point works	No
		P6-01	TOPQ DET 1 SEL	Over-torque checkout action selection 1	0~4	1	0	0: Over-torque checkout is ineffective 1: Continuous running after checkout with speed arrival 2: Continuous running after checkout in running 3: Stop running after checkout with speed arrival 4: Stop running after checkout in running	No
		P6-02	TOPQ DET 1 LVL	Over-torque checkout level 1	0~300	1%	150		No
		P6-03	TORQ DET 1 TIME	Over-torque checkout time 1	0.0~10.0	0.1sec	0.1		No
		P6-04	TOPQ DET 2SEL	Over-torque checkout action selection 2	0~4	1	0	0: Over-torque checkout is ineffective 1: Continuous running after checkout with speed arrival 2: Continuous running after checkout in running 3: Stop running after checkout with speed arrival 4: Stop running after checkout in running	No
		P6-05	TORQ DET 2 LVL	Over-torque checkout level 2	0~300	1%	150		No
P6-06		TOPQ DET 2 TIME	Over-torque checkout time 2	0.0~10.0	0.1sec	0.1		No	
P7-01	TORQ LIMIT FWD	Torque limit in forward rotation	0~300	1%	200		No		

Function	Parameters		Name	Setting Range	Min Setting Unit	Factory Setting Value	Reference Column	Changeable or not in Running	
Protection Function	Torque Limit	P7-02	TORQ LIMIT REV	Torque limit in reverse running	0-300	1%	200		No
		P7-03	TORQ LMT FWD RGN	Torque limit in forward running regeneration	0-300	1%	200		No
		P7-04	TOPQ LMT REV RGN	Torque limit in reverse running resuscitation	0-300	1%	200		No
	Hardware protection	P8-01	DB RESISTOR PROT	Concealed brake resistor protection	0,1	1	0	0: Concealed brake resistor protection is ineffective 1: Concealed brake resistor protection is effective	No
		P8-02	OH PRE-AL ARM LVL	"OH" Pre-alarm level	50-110	1deg	95		No
		P8-03	OH PRE-ALARM SEL	Action selection after OH pre-alarm level	0-3	1	3	0: Deceleration stop 1: Free stop 2: Emergent stop 3: Continuous running	No
		P8-05	PHLOSS IN SEL	Phase loss protection inside input	0,1	1	0	0: Phase loss protection inside input is ineffective 1: Phase loss protection inside input is effective	No
		P8-07	PH LOSS OUT SEL	Phase loss protection inside output	0,1	1	0	0: Phase loss protection inside output is ineffective 1: Phase loss protection inside output is effective	No
		P8-10	GROUND FAULT SEL	Ground protection	0,1	1	1	0: Ground protection is ineffective 1: Ground protection is effective	No
		P8-17	PRTCT @L-SPD	Reducing carrier frequency at low-speed(Carrier sound below 6HZ)	0,1	1	1,(0)	0: Not reduce carrier wave 1: reduce carrier wave V/F or not, PG sets P8-17=0, P8-19=1	No
P8-19	OL2 CHARA@L-SPD	"OL2" Characteristic selection at low-speed	0,1	0	0,(1)	0: OL2 is ineffective at low-speed: OL 2 is effective at low-speed	No		
Operating Apparatus	Display Selection	O1-01	USER MONITOR SEL	User monitor selection	4-29	1	6		Yes
		O1-02	POWER-ON MONITOR	Monitor project selection as power-on	1-4	1	1	1:frequency instruction 2:output frequency 3:output current 4: control mode	Yes
		O1-03	DISPL AY SCALING	Frequency display scaling	0-339999	1	0		No
		O1-04	DISPLAY UNITS	Unit setting for frequency instruction	0,1	1	0	0:HZ 1: r/min	No
		O1-05	MENU SELECT	Main menu MODBUS address	0,1	0	0	0:Om MENU 1:MODBUS address	No
	Keyfunction	O2-01	PANEL/FWD	"PANEL/FWD" Key function selection	0,1	1	1	0: "PANEL/FWD" Key is ineffective 1: "PANEL/FWD" Key is effective	No
		O2-02	OPERS STOP KEY	"STOP" Key function selection	0,1	1	1	0: "STOP" Key is ineffective 1: "STOP" Key is effective	No
		O2-03	USER DEFAULTS	Initial reset of user parameters	0,1,2	1	1	0: Initial data restore 1: Initial data reset	No
		O2-05	OPER ATOR M.O.P	Setting method selection of frequency instruction	0,1	1	0	0: "ENTER" key necessary 1: "ENTER" key unnecessary	No
		O2-06	OPER DETECTION	Action selection as operating apparatus power off	0,1	1	0	0: continue to run as operating apparatus power off 1: abnormal display as operating apparatus power off	No
		O2-07	EL APSED TIME SEL	Elapsed running time setting	0-65535	1hour	-		No
		O2-08	EL APSED TIME RUN	Elapsed running time setting	0,1	1	0	0: Elapsed power-on time 1: Elapsed running time	No

Parameters	Parameters	Name	Min. setting unit	Reference Column	Analog Monitoring	
Monitoring Status	M1-01	FREQ REFERENCE	Frequency instruction	0.01HZ		10V/max. output frequency
	M1-02	OUTPUT FRQ	Output frequency	0.01HZ		10V/ max. output frequency
	M1-03	OUTPUT CURRENT	Output current	0.1A		10V/converter rated current
	M1-04	CONTROL METHOD	Control method	-	0: V/F control 1: V/F control with PG 2: Vector control without PG 3: Vector control with PG	
	M1-05	MOTOR SPEED	Motor speed	001HZ		10V/ max. output frequency
	M1-06	OUTPUT VOLTAGE	Output voltage	0.1V		10V/200V or 10V/400V
	M1-07	DC BUS VOLTAGE	Direct voltage	1V		10V/400V or 10V/800V
	M1-08	OUTPUTKWATIS	Output power	0.1kw		10V/ converter volume(KW)
	M1-09	TORQUE REFERENCE	Torque instruction(internal)	0.1%		10V/Motor rated torque
	M1-10	INPUTTERM STS	Input terminal status		<div style="border: 1px solid black; padding: 2px; display: flex; justify-content: space-around;"> 00000000 </div> <ul style="list-style-type: none"> 1: Duct pilot terminal FWD "closed" 1: Duct pilot terminal REV "closed" 1: Duct pilot terminal EF "closed" 1: Duct pilot terminal RST "closed" 1: Duct pilot terminal MS1 "closed" 1: Duct pilot terminal MS2 "closed" 1: Duct pilot terminal JOG "closed" 1: Duct pilot terminal BX "closed" 	
	M1-11	OUTPUT TERM STS	Output terminal status		<div style="border: 1px solid black; padding: 2px; display: flex; justify-content: space-around;"> 00000000 </div> <ul style="list-style-type: none"> 1: Duct pilot terminal RA-RC "closed" 1: Duct pilot terminal Y1 "closed" 1: Duct pilot terminal Y2 "closed" 0: Not used 0: Not used 0: Not used 1: Abnormal output contact point 	
	M1-12	INT CT1 STS1	Running status		<div style="border: 1px solid black; padding: 2px; display: flex; justify-content: space-around;"> 00000000 </div> <ul style="list-style-type: none"> 1: In running 1: At zero speed 1: In reverse rotation 1: With homing signal input 1: With speed arrival 1: Converter gets ready to finish 1: Light fault 1: Heavy fault 	
	M1-13	ELAPSED TIME	Elapsed running time	1hour		-
	M1-14	SOFTVERSION:	Soft numbering	-		-

Parameters	Parameters		Name	Min. setting unit	Reference Column	Analog Monitoring
Monitoring Status	M1-15	TERM FIV LEVEL	Terminal FIV input voltage	0.1%		10V/100%
	M1-16	TERM FIC LEVEL	Terminal FIC input voltage	0.1%		10V/100%
	M1-17	TERM MFLEVEL	Terminal MFI input voltage	0.1%		10V/100%
	M1-18	MOT SEC CURRENT	Motor secondary current	0.1%		10V/Motor rated current
	M1-19	MOT EXC CURRENT	Motor exciter current	0.1%		10V/Motor rated current
	M1-20	SFS OUTPUT	SPS output	0.01HZ		10V/Motor Max. output frequency
	M1-21	ASR INPUT	ASR input	0.01%		10V/Motor Max. output frequency
	M1-22	ASR OUTPUT	ASR output	0.01%		10V/Motor Max. output frequency
	M1-23	SPEED DEVIATION	Speed deviation	0.01%		10V/Motor Max. output frequency
	M1-24	PID FEEDBACK	PID feedback	0.01%		
	M1-25	DI-16 REFERENCE	D1-16H input status	-		
	M1-26	VOLTAGE REE(VQ)	Output voltage Vq	0.1V		10V/200V or 10/400V
	M1-27	VOLTAGE REE(VD)	Output voltage Vd	0.1V		10V/200V or 10/400V
	M1-28	RISC VERSION:	Soft numbering	-		-
	M1-32	ACR(Q) OUTPUT		-		-
	M1-33	ACR (Q) OUTPUT		-		-
	M1-34	OPB DETECTED		-		-
	M1-35	ZERO SERVO PULSE		0		-
M1-36	PID INPUT		0.00%		-	
M1-37	PID OUTPUT		0.00%		-	
M1-38	PID SETPOINT		0.00%		-	
Abnormal Status	M2-01	CURRENT FAULT	Present fault	-		-
	M2-02	LAST FAULT	Past fault	-		-
	M2-03	FREQUENCY REF	Frequency instruction at abnormal status	0.01HZ		-
	M2-04	OUTPUT FREQ	Output frequency at abnormal status	0.01HZ		-
	M2-05	OUTPUT CURRENT	Output current at abnormal status	0.1A		-
	M2-06	MOTOR SPEED	Motor speed at abnormal status	0.01HZ		-
	M2-07	OUTPUT VOLTAGE	Voltage instruction at abnormal status	0.1V		-

Parameters	Parameters	Name	Min. setting unit	Reference Column	Analog Monitoring
Abnormal Status	M2-08	DC BUS VOLTAGE	Direct current voltage at abnormal status	1V	
	M2-09	OUTPUT KWATTS	Output power at abnormal status	0.1KW	
	M2-10	TORQUE REFERENCE	Torque instruction at abnormal status	0.1%	
	M2-11	INPUT TERM STS	Input Terminal status	-	As M1-10
	M2-12	OUTPUT TERM STS	Output Terminal status	-	As M1-11
	M2-13	INVERTER STATUS	Running status	-	As M1-12
	M2-14	ELAP SED TIME	Elapsed running time	1hour	
Abnormal Resume	M3-01	LAS T FAULT	Last faults	-	
	M3-02	FAULT MESSAQE 2	Faults of first two times	-	
	M3-03	FAULT MESSAQE 3	Faults of first three times	-	
	M3-04	FAULT MESSAQE 4	Faults of first four times	-	
	M3-05	ELAP SED TIME 1	Elapsed running time before the last fault	1hour	
	M3-06	ELAP SED TIME 2	Elapsed running time before the first two times	1hour	
	M3-07	ELAP SED TIME 3	Elapsed running time before the first three times	1hour	
	M3-08	ELAP SED TIME 4	Elapsed running time before the first four times	1hour	

8. The description of malfunction and countermeasures of the frequency converter

Fault Display	Fault Contents	Instruction	Processing Method	Grade
UV DC BUS UNDERVOLT	Transient power-cut checkout	4. Direct current voltage of the primary circuit is lower than undervoltage detection level 5. Contactor of primary circuit is open 6. Voltage of the controlling circuit is lower than undervoltage detection level	-	2
UV1 DC BUS UNDERVOLT	Primary circuit undervoltage(PUV)	Direct current voltage of the primary circuit in running is lower than "undervoltage detection level" 15ms (transient protection 2s) Undervoltage detection level: 220V Grade: about under 190V 440V Grade: about under 380V	1. Check power voltage and subsidiary wires 2. Check if power volume and power system is normal or not	1
UV2 UNDERVOLT FAULT	Controlling circuit undervoltage(CUV)	Voltage of the controlling circuit is lower than undervoltage detection level	1. Check power voltage and subsidiary wires 2. Check if power volume and power system is normal or not	1
UV3 UNDERVOLT FAULT	Inherent electromagnetism contactor fault	Contactor of primary circuit is open	-	1
OC OVERCURRENT	Over-current(OC)	Converter output current exceed OC level	1. Check if motor's resistance and insulation is normal or not 2. Postpone the time of acceleration and deceleration	1
OV OVERVOLTAGE	Over-voltage(OV)	Direct current voltage of the primary circuit is higher than undervoltage detection level 220V Grade: about under 400V 440V Grade: about under 800V	Postpone deceleration time, load braking controller and electric resistance	1
GF GROUNDING	Ground fault(GF)	Converter output ground current exceed more than 50% of converter rated current	1. Check if motor's insulation is deteriorated or not 2. Check if subsidiary wires between the converter and motor is broken or not	1
SC	Load short circuit(SC)	Converter output side is short circuit	Check if motor's resistance and insulation is normal or not	1
PUF	Fuse broken(FU)	1. Transistor pattern assembly of primary circuit happen faults 2. Fuse of direct current circuit is broken	1. Check if the fuse of transistor pattern assembly is broken or not 2. Check if the over-load side has the situations such as short circuit, ground faults, and so on or not.	1
OH1 HEATSNKMAX TEMP	Heat-sinking base overheated(OH1)	Temperature of cooling radiating plate of transistor pattern assembly is more than permissible value	Check if the radiating plate's function is normal or not, and the temperature around it is not more than rated temperature or not.	1
OL1 MOTOR OVERLOAD	Motor overloaded(OL1)	Output current exceeds motor overloaded volume	Reduce load	1
OL2 INVERTER OVERLOAD	Converter overloaded(OL2)	Output current exceeds converter rated current 150%/minute	Reduce load and postpone acceleration time	1
OL3 OVERTORQUEDE T1	Over-torque detection1(OL3)	Response will happen according to setting mode of "P6-01" after setting time of "P6-03", when torque or current value exceed setting value of "P6-02".	Reduce load	1/2

Fault Display	Fault Contents	Instruction	Processing Method	Grade
OL4 OVERTORQUEDE T2	Over-torque detection 2(OL4)	Response will happen according to setting mode of "P6-01" after setting time of "P6-03", when torque or current value exceed setting value of "P6-05".	Reduce load	1/2
RR BRAKING TRANSISTOR FAULT	Braking transistor fault	Braking transistor works worse	Repair converter	1
RH BRAKINGRESIST OR UNIT OVERHEAT	Braking resistor overheat	Temperature of braking resistor is higher than permissible value	Check braking time and used frequency of braking resistor	1
OS OVERSPEED	Over-speed(OS)	Motor speed exceed speed level(61-08)	-	1
PGO PG DISCONNECTION	PG disconnection(PG O)	PG disconnection	1. Check PG connection 2. Check if motor axis is blocked or not	1
DEV EXCESSIVE SPEED DEVIATION	Excessive speed deviation(DEV)	Value difference between the speed instruction and speed feedback exceeds deviation level(61-10)	Check over-load or not	2
EF OPERATION REFERENCE FAULT	Operation instruction is bad	Instruction of forward rotation and reverse rotation coexist for more than 0.5 seconds	Check control sequence, instruction of forward rotation and reverse rotation can't coexist	2
EF3- EF8EXTERNAL TERMINAL EF EXTERNAL FAULT	External fault in terminal EF Input EF4- EF8terminal RST, MS1, MS2,JOG,BX	Abnormal signal is input to external terminal 3-8	M1-10 affirms that abnormal signal is input to terminal Check out according to abnormal situation of terminal	1
OPE 01 KVA SELECTION FAULT	Setting of converter volume fault	Converter parameters' (02-04)setting is bad	Adjust setting value	3
OPE 02 CONSTANT SETTING RANGE FAULT	Parameters setting is bad	Parameters' setting exceed setting value	Adjust setting value	3
OPE 03 MULTIFUNCTION INPUT SELECTION	Multifunction input setting is bad	Setting value of T1-01-06 doesn't comply with the order from small to large, or it reset the same value	Adjust setting value	3
OPE 06 PG OPT MISSING	Control mode selection is bad	Feedback card isn't fixed when 11-02 is set into 1.3	Adjust setting value or fix feedback card	3
OPE 08	Multifunction input selection is bad	1. Choose parameters that 64-01, 02 can not use 2. Choose parameters that T1-01-06, T2-01- 03, T3-05, T3-09, T4-01, T4-04 control mode can not use 3. Choose parameters that O1-01 control mode can not use	Reset parameters	4

Fault Display	Fault Contents	Instruction	Processing Method	Grade
OPE 10 V/F PATTERNSETTING	V/F parameters setting is bad	51-04-10 must comply with the following: F max FA>FB F(min) (51-04) (51-06) (51-07) (51-09)	Adjust setting value	4
OPE 11 CARRFRQ/ON-DELAY	Parameters setting is bad	Parameters setting value: 1.36-01>5KHZ, but 36-02<02 5KHZ 2.36-03>6 but 36-02>36-01	Adjust setting value	4
COMMUNICATIO NLINK ERROR	Control circuit communication link error 1	The links between operator and panel fault within 5 seconds after power-on	1. Restart to fix digit operator 2. Check subsidiary wires of controlling circuit	1
VPC MAINBOARD LINK ERROR	Control circuit communication link error 2	MPU marginal parts error, or over-interference	Check grounding, remove interference source, or replace controlling panel	1
CPF 02 CONTROL CIRCUIT FAULT	Base blocking(BB) circuit fault	Converter control panel fault	replace controlling panel	1
CPF 03 EEPROM ERROR	EEPROM ERROR S_RAM FAULT	Converter control panel fault	replace controlling panel	1
CPF 04 CONSTANT DESTRUCTION	A/D converter in CPU error	Converter control panel fault	replace controlling panel	1
CPF 05 A/D CONVERTER FAULT IN CPU	A/D converter in CPU error	Converter control panel fault	replace controlling panel	1
CPF 06 OPTION CONNECTION FAULT	Marginal interface card connection fault	Marginal interface card connection fault	Restart to fix marginal interface card	1
CF	Control fault	Without PG vector control mode running, torque limit continues for over 3 seconds in deceleration stopping	Check if motor parameters are right or not	1
PF	Input phase loss	1. Converter input power phase loss 2. Three phases of input voltage is unbalanced	1. Check if power voltage is normal or not 2. Check if input terminal point is locked or not	1
LF OPEN-PHASE LOAD	Output phase loss(LF)	Power phase loss in converter output side	Check if screws and subsidiary wires of output terminal point are normal or not Check motor three-phase resistance	1
OPR OPER DISCONNECT	Operator disconnect	Operator disconnection in running	Check operator's connection	1
SVE	Zero servo error	PG value of motor feedback exceeds over ten thousand times in zero servo running	1. Setting size of torque limit 2. Loaded torque is overlage 3. Check if PG signal is interfered or not by noise	1
ERR EEPROM WRITING ERROR	EEPROM writing error	Right materials can't be input to EEPROM in parameters initialization	Exchange controlling panel	2

Fault Display	Fault Contents	Instruction	Processing Method	Grade
CALL SI-B TRANSMISSION ERROR	SI-B Transmission error	Controlling signal abnormal after power-on	Restart to check controlling signal of transmitter	3
CE MEMOBUS COM ERR	Transmission error	Normal signal can't be received within 2 seconds after controlling signal is sent	Restart to check controlling signal of transmitter	1
BUS	Transmission error	Setting mode of received running and frequency instruction, transmission fails	Check transmission and signal	1
INVMODEL ERROR	Converter volume error	Horsepower as stored parameter is inconsistent with that of running converter in executing parameter reproduction	Parameters reproduce only under same specification, same horsepower, same controlling mode(11-02)	
*SOFT VER ERROR	Soft version of converter error	Soft version(M1-14) as stored parameter is inconsistent with that of running converter in executing reproduction parameters	Parameters reproduce only under same specification, same horsepower, same controlling mode(11-02)	
CRC-CHECK ERR	Communication contract-check error	Marginal signal has feedback, but wrong	Check connection and use isolation line to prevent interference	
TIME OUT	Communication time out	Marginal signal has no feedback	Check connection and circumference	
NO DATA	Parameter storage fail	NO parameters in storage digital operator		
VERIFY ERROR	Content contrast between converter parameter and storage parameter error			

The definition and instruction of error grade:
 1: Heavy error, motor stops naturally, abnormal presentation of error display on digital operator, abnormal contact point output EA,EC is on.
 2: Light error, motor stops naturally, abnormal presentation of error display on digital operator, abnormal contact point is off, multifunction output is on.
 3: Warning,, converter doesn't work, abnormal presentation of error display on digital operator, abnormal contact point and multifunction output point don't work.
 4: Light error, converter doesn't work, abnormal presentation of error display on digital operator, abnormal contact point and multifunction output point don't work.

8.1 External braking resistor selection

- (1) "Qma Science & Technology" Q-7000-EL converter isn't fixed braking resistor inside. This converter must be fix braking resistor under the condition that the inertia of load is large, or start and stop is frequent. The following form is operation specification of "Qma Science & Technology" Q-7000-EL converter. The use of resistor can not be lower than the braking resistor's number of the following form. The wattage of the braking resistor must be higher than that of the following form.
- (2) (Stalling anti-function in deceleration) must be set 0 when the braking resistor is used, P3-04=0
- (3) The machines above 220V Grade 15 HP (11KW) and above 440V Grade 20 HP (15KW) need be fixed the braking controller.

Qma-EL Converter			Additional braking resistor		
Voltage Grade	Max. Applied Motor Volume HP(KW)Modes		Resistor, Ωspecification:, Watt		Used number
	220V TO 230V	3HP(2.2KW)	EL- 0222	40Ω	
5HP(3.7KW)		EL- 0322	30Ω	500W	1
7.5HP(5.5KW)		EL- 0522	20Ω	1000W	1
10HP(7.5KW)		EL- 0722	20Ω	1000W	1
15HP(11KW)		EL- 1122	27.2Ω	1200W	2
20HP(15KW)		EL- 1522	20Ω	1500W	2
25HP(18.5KW)		EL- 1822	27.2Ω	1200W	4
30HP(22KW)		EL- 2222	27.2Ω	1200W	4
40HP(30KW)		EL- 3022	27.2Ω	1200W	6
Voltage Grade	Max. Applied Motor Volume HP(KW)Modes		Resistor specification: ΩWatt		Used number
	380V TO 460V	3HP(2.2KW)	EL- 0244	200Ω	
5HP(3.7KW)		EL- 0344	150Ω	500W	1
7.5HP(5.5KW)		EL- 0544	75 Ω	1000W	1
10HP(7.5KW)		EL- 0744	75 Ω	1000W	1
15HP(11KW)		EL- 1144	75 Ω	1000W	2
20HP(15KW)		EL- 1544	75 Ω	1000W	2
25HP(18.5KW)		EL- 1844	100Ω	1200W	4
30HP(22KW)		EL- 2244	100Ω	1200W	4
40HP(30KW)		EL- 3044	100Ω	1200W	6
50HP(37KW)		EL- 3744	100Ω	1200W	8
60HP(45KW)		EL- 4544	100Ω	1200W	10
75HP(55KW)		EL- 5544	100Ω	1200W	12
100HP(75KW)		EL- 7544	100Ω	1200W	15
150HP(110KW)		EL- 1104	80 Ω	1800W	16

8.2 External physical dimension of converter

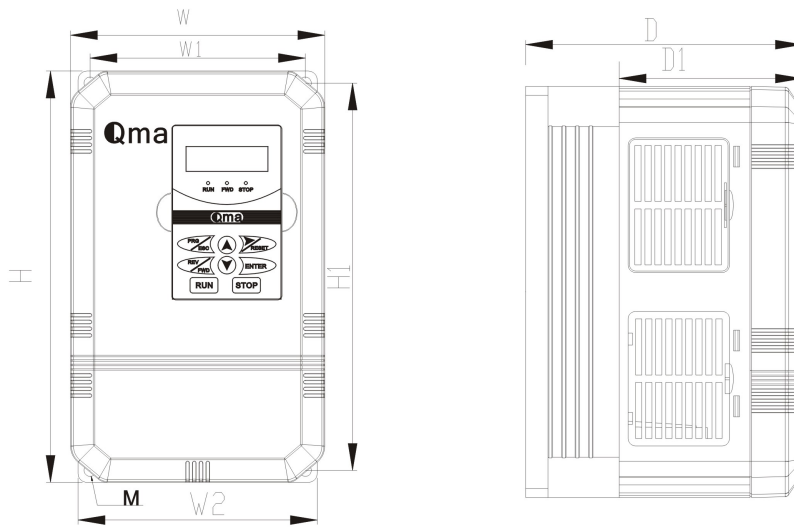

Descriptions		H	H1	W	W1	W2	D	D1	M
AC220V	Q-7000-EL-0222(L3HP) Q-7000-EL-0322(L5HP)	275	259	170	144	160	185	122	M4
AC440V	Q-7000-EL-0244(H3HP) Q-7000-EL-0344(H5HP)								
AC220V	Q-7000-EL-0522(L7.5HP) Q-7000-EL-0722(L10HP)								
AC220V	Q-7000-EL-1122(L15HP)	330	314	230	206	222	226	141	M8
AC440V	Q-7000-EL-0544(H7.5HP) Q-7000-EL-0744(H10HP)								
AC440V	Q-7000-EL-1144(H15HP) Q-7000-EL-1544(H20HP)								
AC220V	Q-7000-EL-1522(L20HP) Q-7000-EL-1822(L25HP)								
AC220V	Q-7000-EL-2222(L30HP) Q-7000-EL-3022(L40HP)	465	450	275	249	265	272	247	M8
AC440V	Q-7000-EL-1844(H25HP) Q-7000-EL-2244(H30HP)								
AC440V	Q-7000-EL-3044(H40HP)								

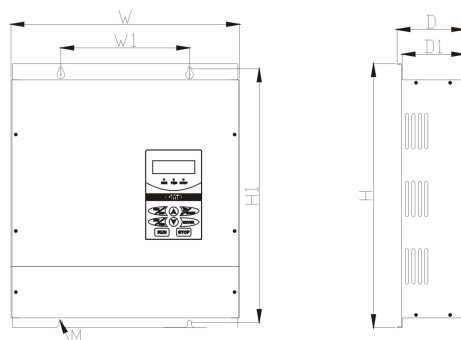

Descriptions		H	H1	W	W1	D	D1	M
AC220V	Q-7000-EL-0222(L3HP) Q-7000-EL-0322(L5HP)	389	374	310	160	105	97	M5
AC440V	Q-7000-EL-0244(H3HP) Q-7000-EL-0344(H5HP)							
AC220V	Q-7000-EL-0522(L7.5HP) Q-7000-EL-0722(L10HP)							
AC220V	Q-7000-EL-1122(L15HP)	410	394	350	200	105	97	M5
AC440V	Q-7000-EL-0544(H7.5HP) Q-7000-EL-0744(H10HP)							
AC440V	Q-7000-EL-1144(H15HP) Q-7000-EL-1544(H20HP)							
AC220V	Q-7000-EL-1522(L20HP) Q-7000-EL-1822(L25HP)							
AC220V	Q-7000-EL-2222(L30HP) Q-7000-EL-3022(L40HP)	585	565	360	200	134	126	M8
AC440V	Q-7000-EL-1844(H25HP) Q-7000-EL-2244(H30HP)							

9. Form of standard specification

Form EL-700		0244	0344	0544	0744	1144	1544	1844	2244	3044	3744	4544	5544	7544	1104	1604
Output	Horsepower volume (HP)	3	5	7	10	15	20	25	30	40	50	60	75	100	150	200
	Rated power (KW)	2.2	3.7	5.5	7.5	11	15	18.5	22	30	37	45	55	75	110	160
	Rated current (A)	6.2	8	14	18	27	34	41	48	65	80	96	128	165	224	302
Power Supply	Rated voltage and frequency	Three phases 380/400/415/440/446V 50/60HZ														
	Permissible voltage fluctuation	10%, - 15%														
	Permissible Frequency fluctuation	±5%														
Control Feature	Control mode	Sinusoidal wave PWM magnetically beam, current torque vector control, V/F control, PG etc. 4 kinds of control modes														
	Speed controlling precision	±0.2% [±0.02% PG attached]														
	Speed controlling range	1:100 [1:1000 PG ATTACHED]														
	Speed response	10HZ [30HZ, 33ms PG attached]														
	Start torque	150%/0.3HZ~200%/0.5HZ [200%/0HZ PG attached]														
	Torque response	20HZ,50ms [40HZ, 25ms PG attached]														
	Torque limit	Parameter setting of 4 kinds of control modes														
	Torque precision	±5%														
	Frequency controlling range	0.1400HZ														
	Frequency precision	Digital signal instruction: ±0.01% (-10℃~+40℃), analogue instruction: ±0.01% (25℃ ±10℃)														
	Frequency setting analysis	Digital signal instruction: ±0.01HZ(below 100HZ), analogue instruction: ±0.03HZ/60HZ(12bit)														
	Frequency output analysis	0.01HZ														
	Overload	Rated torque current 150%/minute														
	Frequency setting signal	Analogue instruction DC 10 ~ +10V, 0 ~ +10V(20KΩ), 4 ~ 20mA(250Ω)														
	Acceleration/ deceleration time	0.01-6000.0s(Acceleration/deceleration time is set respectively, 4 kinds of control time modes selection)														
	Braking torque	20% (plus braking controller reach 150%)														
	Running/stopping setting	Operator, RS-485, Duct Pilot Terminal(frequency setting parameter access control by computer directly)														
Affiliated control function	Parameter copy, PID control, torque control, place control, speed control, multiple speed control, couple control, etc.															
Protection Function	Motor over-load protection	Electronic thermodynamic electric protection														
	Transient over-current	Motor free running stop when rated output current is about 200%/minute														
	Fuse broken	Motor free running stop as fuse breaking protection														
	Overload	Motor free running stop when rated output current is about 150%/minute														
	Over-voltage	Motor free running stop as above DC820V														
	Under-voltage	Motor free running stop as below DC 380V														
	Radiating fin over-heat	Protection by the switch of electro thermal coupling temperature														
	Transient power-cut compensation	Running mode selection changes to zero after power-off within about 2sec, continues to run														
	Stalling anti-function	Stalling anti-function in running and acceleration/deceleration														
	Ground fault	Protection by electronic circuit														
Charge protection	Display as direct current voltage of the primary circuit is above 50V															
Environment	Ambient temperature	-10℃~ +50℃ (internal type)														
	Ambient humidity	Below 90%RH (no condensation phenomenon)														
	Vibration	1G below 20HZ (0.2G above 20HZ)														
	Used place	Indoor (places that there is no corrosive gas, inflammability)														
	Keep temperature	-20℃~ +65℃														
Used environment	Below sea level 1000 meters															