

ARS 60: Absolute Encoders Singleturn. Modular Design for tailor-made solutions.



- Excellent price/performance ratio
- Long LED lifetime as a result of automatic light regulation
- Maximum reliability as a result of opto-ASICs with Chip-on-Board technology
- Interchangeable collets for hollow shaft diameters from 6 to 15 mm and 1/4, 3/8, 1/2 inch.

Whether with face mount flange, servo flange, blind or through hollow shaft with connector or cable outlet, SSI or Parallel interface – ARS 60 absolute singleturn encoders will meet virtually any application profile.

	Number of steps 2 to 32,768
Absolute Encoder Singleturn	

CoreTech[®]
by **SICK** | **STEGMANN**

CoreTech technology permits tailor-made solutions for every application, due to its modular design. ARS 60 absolute encoders singleturn are available with any desired number of steps between 2 und 32,768. Further highlights of this generation of encoders:

- Simple zero adjustment by pressing a button located under a cap on the rear of the encoder or remotely via a signal line.

Thanks to this wide variety of products, there are numerous possible uses, for example in:

- machine tools
- textile machines
- woodworking machines
- packaging machines

Number of steps
2 to 32,768

Absolute Encoder Singleturn

- Connector or cable outlet
- Protection class up to IP 66
- Electrical Interfaces
SSI or Parallel
- Zero adjustment directly on
the encoder or via a remote line

Dimensional drawing face mount flange radial exit

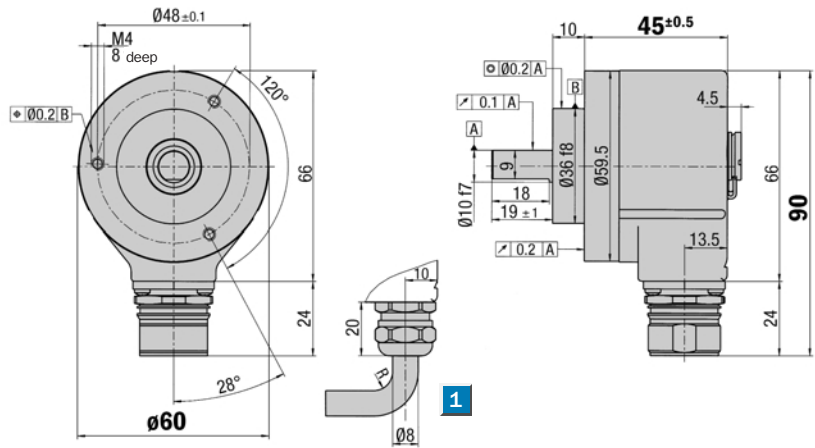

1 R = bending radius min. 40 mm General tolerances according to DIN ISO 2768-mk

Dimensional drawing face mount flange axial exit

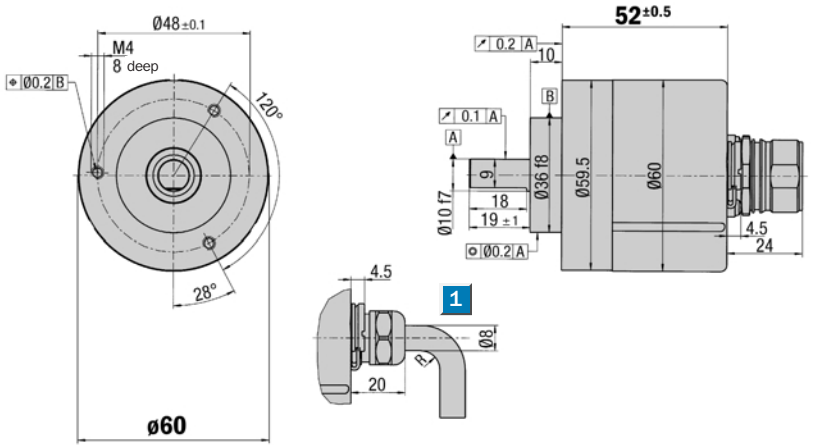

1 R = bending radius min. 40 mm General tolerances according to DIN ISO 2768-mk



PIN and wire allocation see page 18

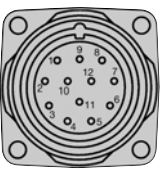

View of the connector M23 fitted to the encoder body SSI

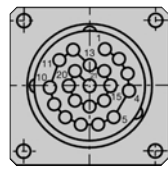

View of the connector M23 fitted to the encoder body Single, Parallel

Accessories
Connection systems
Mounting systems
Adaptor modules

Connection type

Radial cable	Axial cable	Radial connector	Axial connector
--------------	-------------	------------------	-----------------

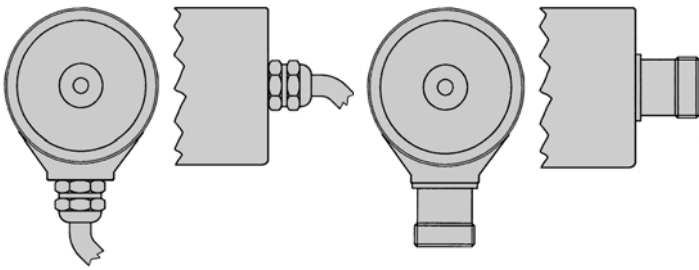

Technical Data acc. to DIN 32878		ARS 60 face mount flange	Flange type											
			face m.											
Solid shaft	10 mm													
Number of steps per revolution	00002 ... 32,768, see ordering information													
Electrical interfaces	SSI or Parallel													
Mass ¹⁾	Approx. 0.3 kg													
Moment of inertia of the rotor	54 gcm ²													
Code direction ²⁾	CW													
Measurement range	1 revolution													
Measuring step	360°/number of steps													
Repeatability	0.005°													
Error limits														
binary number of steps	0.035°													
non-binary number of steps	0.046°													
Measuring step deviation														
binary number of steps	0.005°													
non-binary number of steps	0.016°													
Measured value backlash	0.005°													
Response threshold	0.003°													
Max. angular acceleration	5 x 10 ⁵ rad/s ²													
Max. operating speed														
with shaft seal	6,000 min ⁻¹													
without shaft seal ³⁾	10,000 min ⁻¹													
Operating torque	Typ. 0.3 Ncm													
Start up torque	Typ. 0.4 Ncm													
Permissible shaft loading														
radial	20 N													
axial	10 N													
Bearing lifetime	3.6 x 10 ⁹ revolutions													
Working temperature range	- 20 ... + 85 °C													
Storage temperature range	- 40 ... + 100 °C													
Permissible relative humidity ⁴⁾	90 %													
EMC ⁵⁾														
Resistance														
to shocks ⁶⁾	50/11 g/ms													
to vibration ⁷⁾	20/10 ... 2000 g/Hz													
Protection class acc. IEC 60529														
connector outlet ⁸⁾	IP 65													
cable outlet	IP 66													
Operating voltage range (U_s)	10 ... 32 V													
Operating current														
SSI	Typ. 60 mA													
Parallel	Typ. 90 mA													
Switching level of the control inputs														
	Logic H = 0.7 x U _s													
	Logic L = 0 V ... 0.3 x U _s													
Operation of zero-set ⁹⁾	≥ 100 ms													
Initialisation time after power on	40 ms													

¹⁾ For an encoder with connector outlet

²⁾ Increasing when viewing the clockwise rotating shaft

³⁾ If the shaft seal has been removed by the customer

⁴⁾ Condensation not permitted

⁵⁾ To DIN EN 61000-6-2 and DIN EN 61000-6-3

⁶⁾ To DIN EN 60068-2-27

⁷⁾ To DIN EN 60068-2-6

⁸⁾ With mating connector fitted

⁹⁾ Only with shaft stationary (note initialisation time)

Order information SSI interface

Absolute Encoder Singleturn ARS 60 SSI, face mount flange, solid shaft 10 mm

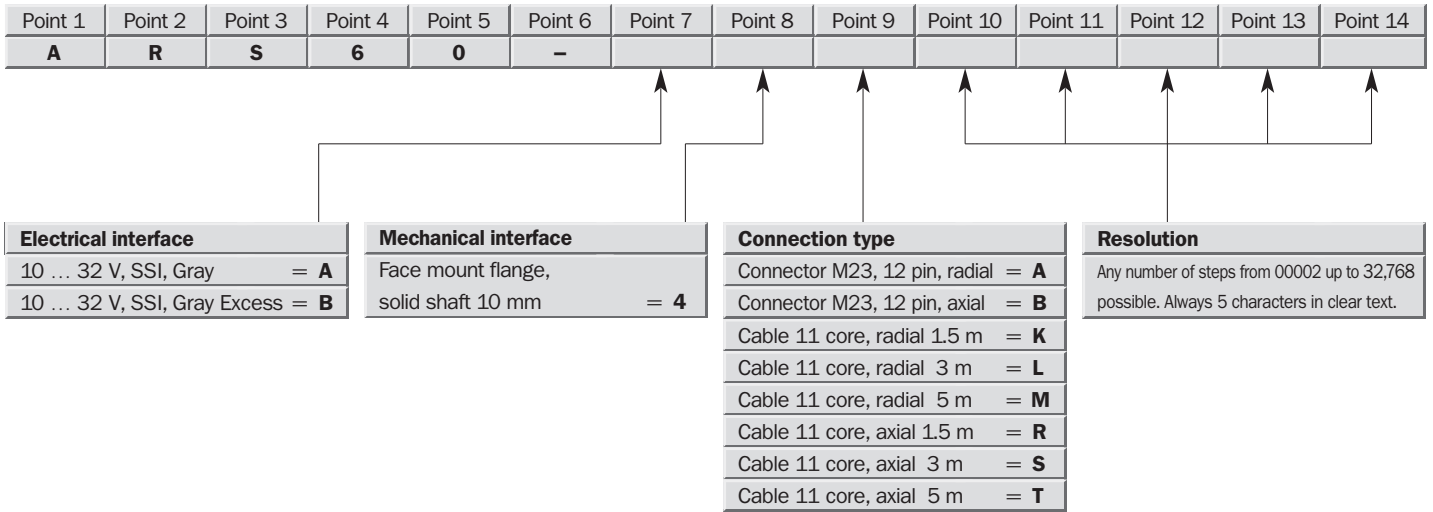

Order example: Absolute Encoder Singleturn ARS 60 SSI

10 ... 32 V, SSI, Gray; face mount flange; connector M23, 12 pin, radial; number of steps: 8,192

Point 1	Point 2	Point 3	Point 4	Point 5	Point 6	Point 7	Point 8	Point 9	Point 10	Point 11	Point 12	Point 13	Point 14
A	R	S	6	0	-	A	4	A	0	8	1	9	2

Please enter your individual encoder here

Point 1	Point 2	Point 3	Point 4	Point 5	Point 6	Point 7	Point 8	Point 9	Point 10	Point 11	Point 12	Point 13	Point 14
A	R	S	6	0	-								

Point 1	Point 2	Point 3	Point 4	Point 5	Point 6	Point 7	Point 8	Point 9	Point 10	Point 11	Point 12	Point 13	Point 14
A	R	S	6	0	-								

Point 1	Point 2	Point 3	Point 4	Point 5	Point 6	Point 7	Point 8	Point 9	Point 10	Point 11	Point 12	Point 13	Point 14
A	R	S	6	0	-								

Order information Parallel interface

Absolute Encoder Singleturn ARS 60 Parallel, face mount flange, solid shaft 10 mm

Point 1	Point 2	Point 3	Point 4	Point 5	Point 6	Point 7	Point 8	Point 9	Point 10	Point 11	Point 12	Point 13	Point 14
A	R	S	6	0	-								

Electrical interface	
10 ... 32 V, parallel, Gray	= F
10 ... 32 V, parallel, Gray Exc.	= G
10 ... 32 V, parallel, BIN	= H
10 ... 32 V, parallel, BCD	= J

Mechanical interface	
Face mount flange, solid shaft 10 mm	= 4

Connection type	
Connector M23, 21 pin, radial	= A
Connector M23, 21 pin, axial	= B
Cable 22 core, radial 1.5 m	= K
Cable 22 core, radial 3 m	= L
Cable 22 core, radial 5 m	= M
Cable 22 core, axial 1.5 m	= R
Cable 22 core, axial 3 m	= S
Cable 22 core, axial 5 m	= T

Resolution	
Any number of steps from 00002 up to 32,768 possible, with the following electrical interfaces:	
10 ... 32 V, parallel, Gray	
10 ... 32 V, parallel, Gray Excess	
10 ... 32 V, parallel, BIN	
Number of steps from 00002 up to 07999 possible, with the electrical interface:	
10 ... 32 V, parallel, BCD	
Always 5 characters in clear text.	

Order example: Absolute Encoder Singleturn ARS 60 Parallel

10 ... 32 V, Parallel, Gray; face mount flange; connector M23, 21 pin, radial; number of steps: 8,192

Point 1	Point 2	Point 3	Point 4	Point 5	Point 6	Point 7	Point 8	Point 9	Point 10	Point 11	Point 12	Point 13	Point 14
A	R	S	6	0	-	F	4	A	0	8	1	9	2

Please enter your individual encoder here

Point 1	Point 2	Point 3	Point 4	Point 5	Point 6	Point 7	Point 8	Point 9	Point 10	Point 11	Point 12	Point 13	Point 14
A	R	S	6	0	-								

Point 1	Point 2	Point 3	Point 4	Point 5	Point 6	Point 7	Point 8	Point 9	Point 10	Point 11	Point 12	Point 13	Point 14
A	R	S	6	0	-								

Point 1	Point 2	Point 3	Point 4	Point 5	Point 6	Point 7	Point 8	Point 9	Point 10	Point 11	Point 12	Point 13	Point 14
A	R	S	6	0	-								

 **Number of steps**
2 to 32,768
Absolute Encoder Singleturn

- Connector or cable outlet
- Protection class up to IP 66
- Electrical Interfaces
SSI or Parallel
- Zero adjustment directly on
the encoder or via a remote line

Dimensional drawing servo flange radial exit

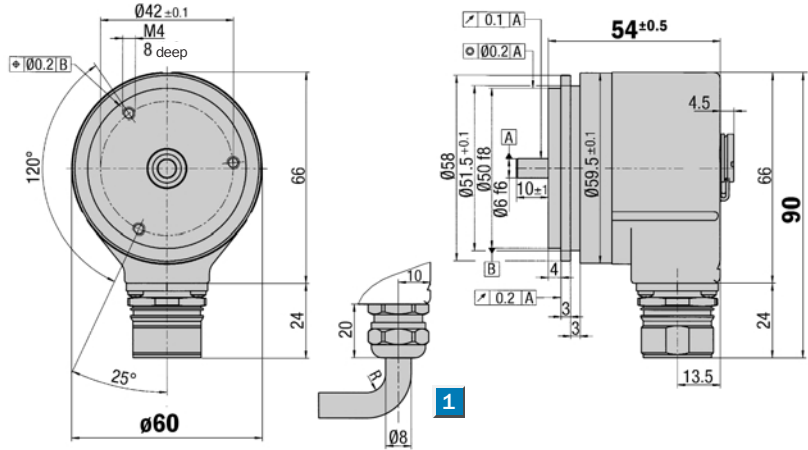

1 R = bending radius min. 40 mm

General tolerances according to DIN ISO 2768-mk

Dimensional drawing servo flange axial exit

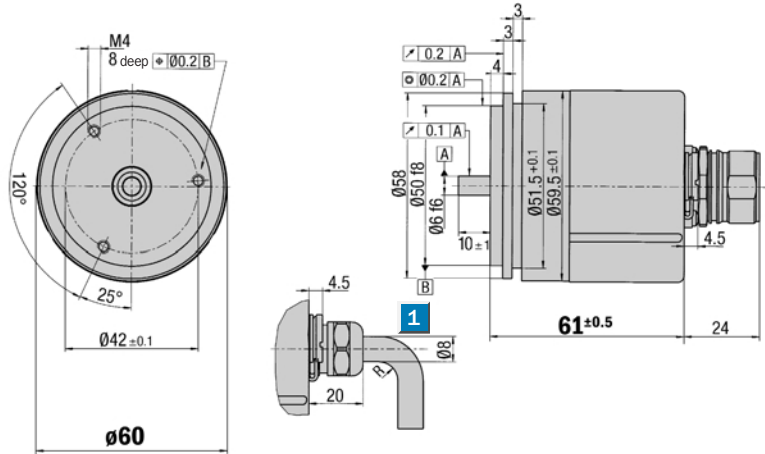

1 R = bending radius min. 40 mm

General tolerances according to DIN ISO 2768-mk

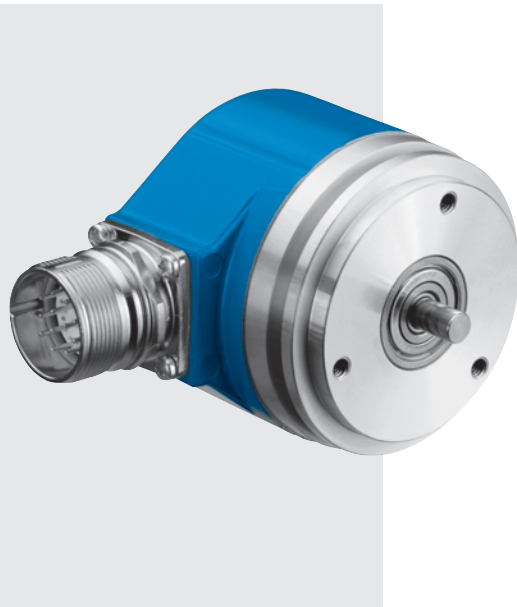

PIN and wire allocation see page 18

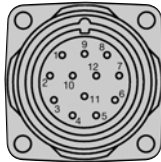

View of the connector M23 fitted to the encoder body SSI

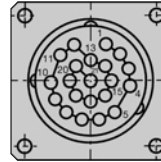

View of the connector M23 fitted to the encoder body Single, Parallel

Accessories

- Connection systems
- Mounting systems
- Adaptor modules

Connection type

- Radial cable
- Axial cable
- Radial connector
- Axial connector

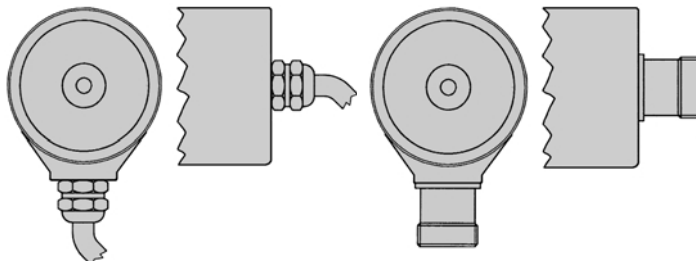

Technical Data acc. to DIN 32878		ARS 60 servo flange	Flange type											
			servo											
Solid shaft	6 mm													
Number of steps per revolution	00002 ... 32,768, see ordering information													
Electrical interfaces	SSI or Parallel													
Mass ¹⁾	Approx. 0.3 kg													
Moment of inertia of the rotor	48 gcm ²													
Code direction ²⁾	CW													
Measurement range	1 revolution													
Measuring step	360°/number of steps													
Repeatability	0.005°													
Error limits														
binary number of steps	0.035°													
non-binary number of steps	0.046°													
Measuring step deviation														
binary number of steps	0.005°													
non-binary number of steps	0.016°													
Measured value backlash	0.005°													
Response threshold	0.003°													
Max. angular acceleration	5 x 10 ⁵ rad/s ²													
Max. operating speed														
with shaft seal	6,000 min ⁻¹													
without shaft seal ³⁾	10,000 min ⁻¹													
Operating torque	Typ. 0.2 Ncm													
Start up torque	Typ. 0.25 Ncm													
Permissible shaft loading														
radial	20 N													
axial	10 N													
Bearing lifetime	3.6 x 10 ⁹ revolutions													
Working temperature range	- 20 ... + 85 °C													
Storage temperature range	- 40 ... + 100 °C													
Permissible relative humidity ⁴⁾	90 %													
EMC ⁵⁾														
Resistance														
to shocks ⁶⁾	50/11 g/ms													
to vibration ⁷⁾	20/10 ... 2000 g/Hz													
Protection class acc. IEC 60529														
connector outlet ⁸⁾	IP 65													
cable outlet	IP 66													
Operating voltage range (U_s)	10 ... 32 V													
Operating current														
SSI	Typ. 60 mA													
Parallel	Typ. 90 mA													
Switching level of the control inputs														
	Logic H = 0.7 x U _s													
	Logic L = 0 V ... 0.3 x U _s													
Operation of zero-set ⁹⁾	≥ 100 ms													
Initialisation time after power on	40 ms													

¹⁾ For an encoder with connector outlet

²⁾ Increasing when viewing the clockwise rotating shaft

³⁾ If the shaft seal has been removed by the customer

⁴⁾ Condensation not permitted

⁵⁾ To DIN EN 61000-6-2 and DIN EN 61000-6-3

⁶⁾ To DIN EN 60068-2-27

⁷⁾ To DIN EN 60068-2-6

⁸⁾ With mating connector fitted

⁹⁾ Only with shaft stationary (note initialisation time)

Absolute Encoder Singleturn ARS 60 SSI and Parallel, servo flange

Order information SSI interface

Absolute Encoder Singleturn ARS 60 SSI, servo flange, solid shaft 6 mm

Point 1	Point 2	Point 3	Point 4	Point 5	Point 6	Point 7	Point 8	Point 9	Point 10	Point 11	Point 12	Point 13	Point 14
A	R	S	6	0	-								

Electrical interface	Mechanical interface	Connection type	Resolution
10 ... 32 V, SSI, Gray = A	Servo flange, solid shaft 6 mm = 1	Connector M23, 12 pin, radial = A	Any number of steps from 00002 up to 32,768 possible. Always 5 characters in clear text.
10 ... 32 V, SSI, Gray Excess = B		Connector M23, 12 pin, axial = B	
		Cable 11 core, radial 1.5 m = K	
		Cable 11 core, radial 3 m = L	
		Cable 11 core, radial 5 m = M	
		Cable 11 core, axial 1.5 m = R	
		Cable 11 core, axial 3 m = S	
		Cable 11 core, axial 5 m = T	

Order example: Absolute Encoder Singleturn ARS 60 SSI

10 ... 32 V, SSI, Gray; servo flange; connector M23, 12 pin, radial; number of steps: 8,192

Point 1	Point 2	Point 3	Point 4	Point 5	Point 6	Point 7	Point 8	Point 9	Point 10	Point 11	Point 12	Point 13	Point 14
A	R	S	6	0	-	A	1	A	0	8	1	9	2

Please enter your individual encoder here

Point 1	Point 2	Point 3	Point 4	Point 5	Point 6	Point 7	Point 8	Point 9	Point 10	Point 11	Point 12	Point 13	Point 14
A	R	S	6	0	-								

Point 1	Point 2	Point 3	Point 4	Point 5	Point 6	Point 7	Point 8	Point 9	Point 10	Point 11	Point 12	Point 13	Point 14
A	R	S	6	0	-								

Point 1	Point 2	Point 3	Point 4	Point 5	Point 6	Point 7	Point 8	Point 9	Point 10	Point 11	Point 12	Point 13	Point 14
A	R	S	6	0	-								

Order information Parallel Interface

Absolute Encoder Singleturn ARS 60 Parallel, servo flange, solid shaft 6 mm

Point 1	Point 2	Point 3	Point 4	Point 5	Point 6	Point 7	Point 8	Point 9	Point 10	Point 11	Point 12	Point 13	Point 14
A	R	S	6	0	-								

Electrical interface	Mechanical interface	Connection type	Resolution
10 ... 32 V, parallel, Gray = F	Servo flange, solid shaft 6 mm = 1	Connector M23, 21 pin, radial = A	Any number of steps from 00002 up to 32,768 possible, with the following electrical interfaces: 10 ... 32 V, parallel, Gray 10 ... 32 V, parallel, Gray Excess 10 ... 32 V, parallel, BIN
10 ... 32 V, parallel, Gray Exc. = G		Connector M23, 21 pin, axial = B	
10 ... 32 V, parallel, BIN = H		Cable 22 core, radial 1.5 m = K	
10 ... 32 V, parallel, BCD = J		Cable 22 core, radial 3 m = L	Number of steps from 00002 up to 07999 possible, with the electrical interface: 10 ... 32 V, parallel, BCD Always 5 characters, in clear text.
		Cable 22 core, radial 5 m = M	
		Cable 22 core, axial 1.5 m = R	
		Cable 22 core, axial 3 m = S	
		Cable 22 core, axial 5 m = T	

Order example: Absolute Encoder Singleturn ARS 60 Parallel

10 ... 32 V, Parallel, Gray; servo flange; connector M23, 21 pin, radial; number of steps: 8,192

Point 1	Point 2	Point 3	Point 4	Point 5	Point 6	Point 7	Point 8	Point 9	Point 10	Point 11	Point 12	Point 13	Point 14
A	R	S	6	0	-	F	1	A	0	8	1	9	2

Please enter your individual encoder here

Point 1	Point 2	Point 3	Point 4	Point 5	Point 6	Point 7	Point 8	Point 9	Point 10	Point 11	Point 12	Point 13	Point 14
A	R	S	6	0	-								

Point 1	Point 2	Point 3	Point 4	Point 5	Point 6	Point 7	Point 8	Point 9	Point 10	Point 11	Point 12	Point 13	Point 14
A	R	S	6	0	-								

Point 1	Point 2	Point 3	Point 4	Point 5	Point 6	Point 7	Point 8	Point 9	Point 10	Point 11	Point 12	Point 13	Point 14
A	R	S	6	0	-								

 **Number of steps**
2 to 32,768

Absolute Encoder Singleturn

- Connector or cable outlet
- Protection class up to IP 66
- Electrical Interfaces
SSI or Parallel
- Zero adjustment directly on
the encoder or via a remote line

Dimensional drawing blind hollow shaft radial exit

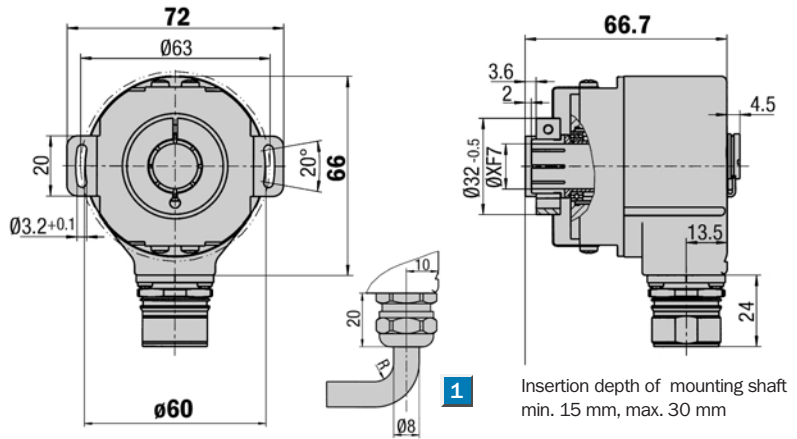

1 R = bending radius min. 40 mm

General tolerances according to DIN ISO 2768-mk

Dimensional drawing blind hollow shaft axial exit

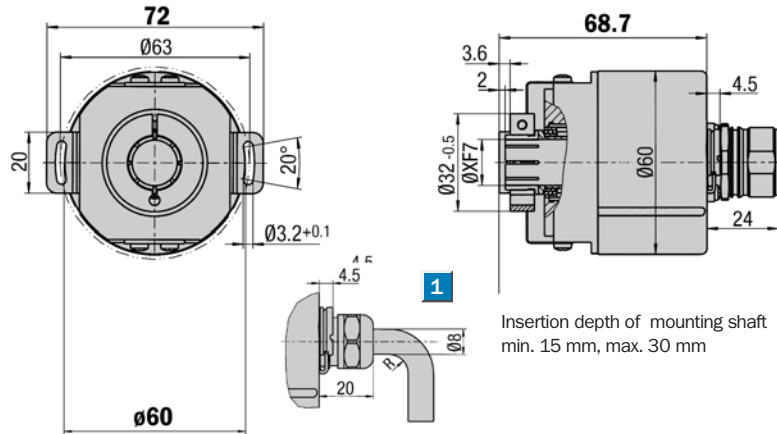

1 R = bending radius min. 40 mm

General tolerances according to DIN ISO 2768-mk

PIN and wire allocation see page 18

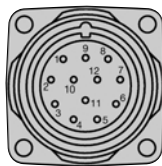

View of the connector M23 fitted to the encoder body SSI

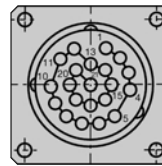

View of the connector M23 fitted to the encoder body Single, Parallel

Accessories
Connection systems
Mounting systems
Collets
Adaptor modules

Connection type

- | | | | |
|--------------|-------------|------------------|-----------------|
| Radial cable | Axial cable | Radial connector | Axial connector |
|--------------|-------------|------------------|-----------------|

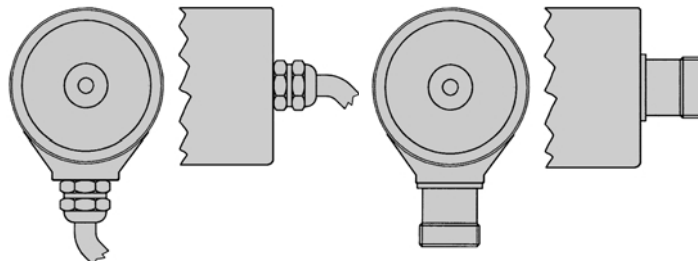

Technical Data acc. to DIN 32878		ARS 60 blind hollow shaft										Flange type									
		blind																			
Hollow shaft diameter	6, 8, 10, 12, 15 mm, 1/4", 3/8", 1/2"																				
Number of steps per revolution	00002 ... 32,768, see ordering information																				
Electrical interfaces	SSI or Parallel																				
Mass ⁴⁾	Approx. 0.3 kg																				
Moment of inertia of the rotor	See Fig. 1																				
Code direction ²⁾	CW																				
Measurement range	1 revolution																				
Measuring step	360°/number of steps																				
Repeatability	0.005°																				
Error limits																					
binary number of steps	0.035°																				
non-binary number of steps	0.046°																				
Measuring step deviation																					
binary number of steps	0.005°																				
non-binary number of steps	0.016°																				
Measured value backlash	0.005°																				
Response threshold	0.003°																				
Max. angular acceleration	5 x 10 ⁵ rad/s ²																				
Max. operating speed	3,000 min ⁻¹																				
Operating torque	Typ. 0.4 Ncm																				
Start up torque	Typ. 0.6 Ncm																				
Permissible movement of the drive element																					
radial movement static/dynamic	± 0.3/± 0.1 mm																				
axial movement static/dynamic	± 0.5/± 0.2 mm																				
Bearing lifetime	3.6 x 10 ⁹ revolutions																				
Working temperature range	- 20 ... + 85 °C																				
Storage temperature range	- 40 ... + 100 °C																				
Permissible relative humidity ³⁾	90 %																				
EMC ⁴⁾																					
Resistance																					
to shocks ⁵⁾	50/11 g/ms																				
to vibration ⁶⁾	20/10 ... 2000 g/Hz																				
Protection class acc. IEC 60529																					
connector outlet ⁷⁾	IP 65																				
cable outlet	IP 66																				
Operating voltage range (Us)	10 ... 32 V																				
Operating current																					
SSI	Typ. 60 mA																				
Parallel	Typ. 90 mA																				
Switching level of the control inputs																					
	Logic H = 0.7 x Us																				
	Logic L = 0 V ... 0.3 x Us																				
Operation of zero-set ⁸⁾	≥ 100 ms																				
Initialisation time after power on	40 ms																				

¹⁾ For an encoder with connector outlet
²⁾ Increasing when viewing the clockwise rotating shaft
³⁾ Condensation not permitted

⁴⁾ To DIN EN 61000-6-2 and DIN EN 61000-6-3
⁵⁾ To DIN EN 60068-2-27
⁶⁾ To DIN EN 60068-2-6
⁷⁾ With mating connector fitted
⁸⁾ Only with shaft stationary (note initialisation time)

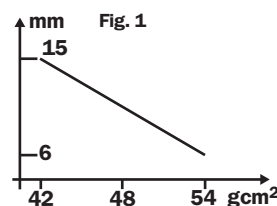

Order information see pages 12/13

Order information SSI Interface

Absolute Encoder Singleturn ARS 60 SSI, blind hollow shaft

Point 1	Point 2	Point 3	Point 4	Point 5	Point 6	Point 7	Point 8	Point 9	Point 10	Point 11	Point 12	Point 13	Point 14
A	R	S	6	0	-								

Electrical interface	Mechanical interface	Connection type	Resolution
10 ... 32 V, SSI, Gray = A	Blind hollow shaft ¹⁾ = A	Connector M23, 12 pin, radial = A	Any number of steps from 00002 up to 32,768 possible. Always 5 characters in clear text.
10 ... 32 V, SSI, Gray Excess = B	¹⁾ Collets for 6, 8, 10, 12 mm and 1/4", 3/8" and 1/2" as accessories, separate order item (see below). For 15 mm shaft diameter collet is not needed.	Connector M23, 12 pin, axial = B	
		Cable 11 core, radial 1.5 m = K	
		Cable 11 core, radial 3 m = L	
		Cable 11 core, radial 5 m = M	
		Cable 11 core, axial 1.5 m = R	
		Cable 11 core, axial 3 m = S	
		Cable 11 core, axial 5 m = T	

Order example: Absolute Encoder Singleturn ARS 60 SSI

10 ... 32 V, SSI, Gray; blind hollow shaft; connector M23, 12 pin, radial; number of steps 8,192

Point 1	Point 2	Point 3	Point 4	Point 5	Point 6	Point 7	Point 8	Point 9	Point 10	Point 11	Point 12	Point 13	Point 14
A	R	S	6	0	-	A	A	A	0	8	1	9	2

Please enter your individual encoder here

Point 1	Point 2	Point 3	Point 4	Point 5	Point 6	Point 7	Point 8	Point 9	Point 10	Point 11	Point 12	Point 13	Point 14
A	R	S	6	0	-								

Point 1	Point 2	Point 3	Point 4	Point 5	Point 6	Point 7	Point 8	Point 9	Point 10	Point 11	Point 12	Point 13	Point 14
A	R	S	6	0	-								

Point 1	Point 2	Point 3	Point 4	Point 5	Point 6	Point 7	Point 8	Point 9	Point 10	Point 11	Point 12	Point 13	Point 14
A	R	S	6	0	-								

Collets for blind hollow shaft encoder

Type	Part no.	Shaft diameter
SPZ-006-AD-A	2 029 174	6 mm
SPZ-1E4-AD-A	2 029 175	1/4"
SPZ-008-AD-A	2 029 176	8 mm
SPZ-3E8-AD-A	2 029 177	3/8"
SPZ-010-AD-A	2 029 178	10 mm
SPZ-012-AD-A	2 029 179	12 mm
SPZ-1E2-AD-A	2 029 180	1/2"

Order information Parallel Interface

Absolute Encoder Singleturn ARS 60 Parallel, blind hollow shaft

Point 1	Point 2	Point 3	Point 4	Point 5	Point 6	Point 7	Point 8	Point 9	Point 10	Point 11	Point 12	Point 13	Point 14
A	R	S	6	0	-								

Electrical interface 10 ... 32 V, parallel, Gray = F 10 ... 32 V, parallel, Gray Exc. = G 10 ... 32 V, parallel, BIN = H 10 ... 32 V, parallel, BCD = J	Mechanical interface Blind hollow shaft ¹⁾ = A <small>¹⁾ Collets for 6, 8, 10, 12 mm and 1/4", 3/8" and 1/2" as accessories, separate order item (see below). For 15 mm shaft diameter collet is not needed.</small>	Connection type Connector M23, 21 pin, radial = A Connector M23, 21 pin, axial = B Cable 22 core, radial 1.5 m = K Cable 22 core, radial 3 m = L Cable 22 core, radial 5 m = M Cable 22 core, axial 1.5 m = R Cable 22 core, axial 3 m = S Cable 22 core, axial 5 m = T	Resolution Any number of steps from 00002 up to 32,768 possible, with the following electrical interfaces: 10 ... 32 V, parallel, Gray 10 ... 32 V, parallel, Gray Excess 10 ... 32 V, parallel, BIN Number of steps from 00002 up to 07999 possible, with the electrical interface: 10 ... 32 V, parallel, BCD Always 5 characters, in clear text.
--	--	--	---

Order example: Absolute Encoder Singleturn ARS 60 Parallel

10 ... 32 V, Parallel, Gray; blind hollow shaft; connector M23, 21 pin, radial; number of steps 8,192

Point 1	Point 2	Point 3	Point 4	Point 5	Point 6	Point 7	Point 8	Point 9	Point 10	Point 11	Point 12	Point 13	Point 14
A	R	S	6	0	-	F	A	A	0	8	1	9	2

Please enter your individual encoder here

Point 1	Point 2	Point 3	Point 4	Point 5	Point 6	Point 7	Point 8	Point 9	Point 10	Point 11	Point 12	Point 13	Point 14
A	R	S	6	0	-								

Point 1	Point 2	Point 3	Point 4	Point 5	Point 6	Point 7	Point 8	Point 9	Point 10	Point 11	Point 12	Point 13	Point 14
A	R	S	6	0	-								

Point 1	Point 2	Point 3	Point 4	Point 5	Point 6	Point 7	Point 8	Point 9	Point 10	Point 11	Point 12	Point 13	Point 14
A	R	S	6	0	-								

Collets for blind hollow shaft encoder

Type	Part no.	Shaft diameter
SPZ-006-AD-A	2 029 174	6 mm
SPZ-1E4-AD-A	2 029 175	1/4"
SPZ-008-AD-A	2 029 176	8 mm
SPZ-3E8-AD-A	2 029 177	3/8"
SPZ-010-AD-A	2 029 178	10 mm
SPZ-012-AD-A	2 029 179	12 mm
SPZ-1E2-AD-A	2 029 180	1/2"

 **Number of steps**
2 to 32,768
Absolute Encoder Singleturn

- Connector or cable outlet
- Protection class up to IP 64
- Electrical Interfaces
SSI or Parallel
- Zero adjustment directly on
the encoder or via a remote line

Dimensional drawing through hollow shaft, radial exit

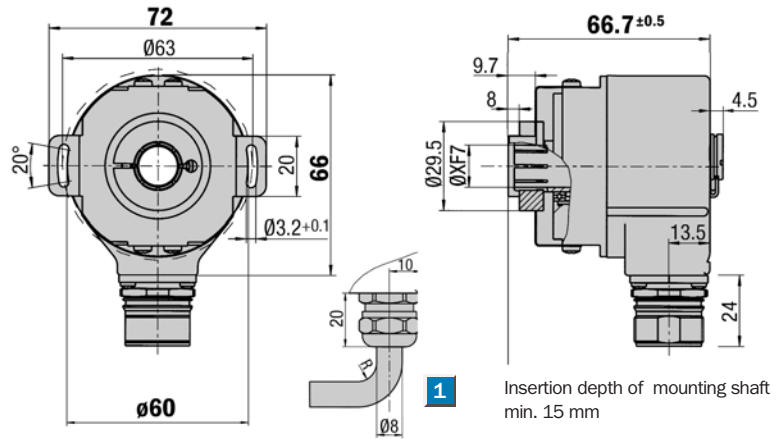

1 R = bending radius min. 40 mm

General tolerances according to DIN ISO 2768-mk

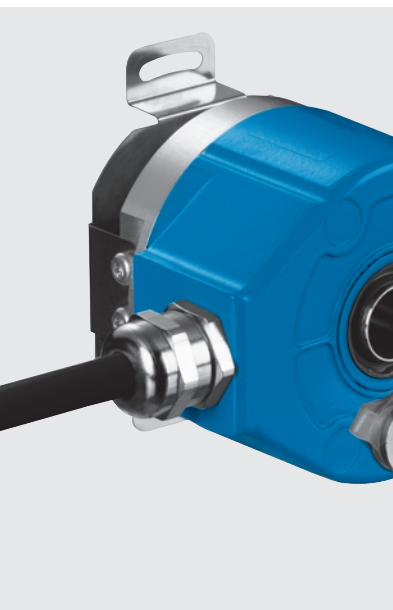

PIN and wire allocation see page 18

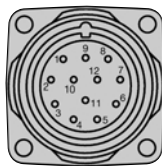

View of the connector M23 fitted to the encoder body SSI

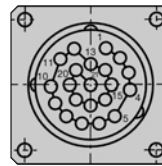

View of the connector M23 fitted to the encoder body Single, Parallel

Accessories

- Connection systems
- Mounting systems
- Collets
- Adaptor modules

Connection type

Radial cable

Radial connector

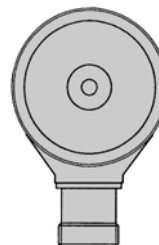
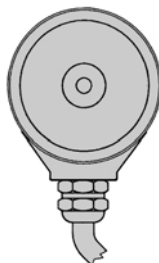

Technical Data acc. to DIN 32878		ARS 60 through hollow shaft		Flange type									
				through									
Hollow shaft diameter	6, 8, 10, 12 mm, 1/4", 3/8", 1/2"												
Number of steps per revolution	00002 ... 32,768, see ordering information												
Electrical interfaces	SSI or Parallel												
Mass ⁴⁾	Approx. 0.3 kg												
Moment of inertia of the rotor	See Fig. 1												
Code direction ²⁾	CW												
Measurement range	1 revolution												
Measuring step	360°/number of steps												
Repeatability	0.005°												
Error limits													
binary number of steps	0.035°												
non-binary number of steps	0.046°												
Measuring step deviation													
binary number of steps	0.005°												
non-binary number of steps	0.016°												
Measured value backlash	0.005°												
Response threshold	0.003°												
Max. angular acceleration	$5 \times 10^5 \text{ rad/s}^2$												
Max. operating speed	$3,000 \text{ min}^{-1}$												
Operating torque	Typ. 1.6 Ncm												
Start up torque	Typ. 2.2 Ncm												
Permissible movement of the drive element													
radial movement static/dynamic	$\pm 0.3/\pm 0.1 \text{ mm}$												
axial movement static/dynamic	$\pm 0.5/\pm 0.2 \text{ mm}$												
Bearing lifetime	$3.6 \times 10^9 \text{ revolutions}$												
Working temperature range	- 20 ... + 85 °C												
Storage temperature range	- 40 ... + 100 °C												
Permissible relative humidity ³⁾	90 %												
EMC ⁴⁾													
Resistance													
to shocks ⁵⁾	50/11 g/ms												
to vibration ⁶⁾	20/10 ... 2000 g/Hz												
Protection class acc. IEC 60529													
connector outlet ⁷⁾	IP 64												
cable outlet	IP 64												
Operating voltage range (U_s)	10 ... 32 V												
Operating current													
SSI	Typ. 60 mA												
Parallel	Typ. 90 mA												
Switching level of the control inputs													
	Logic H = $0.7 \times U_s$												
	Logic L = $0 \text{ V} \dots 0.3 \times U_s$												
Operation of zero-set ⁸⁾	$\geq 100 \text{ ms}$												
Initialisation time after power on	40 ms												

¹⁾ For an encoder with connector outlet

²⁾ Increasing when viewing the clockwise rotating shaft

³⁾ Condensation not permitted

⁴⁾ To DIN EN 61000-6-2 and DIN EN 61000-6-3

⁵⁾ To DIN EN 60068-2-27

⁶⁾ To DIN EN 60068-2-6

⁷⁾ With mating connector fitted

⁸⁾ Only with shaft stationary (note initialisation time)

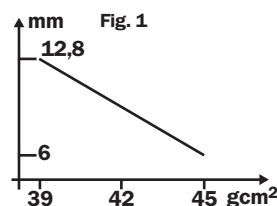

Order information SSI Interface

Absolute Encoder Singleturn ARS 60 SSI, through hollow shaft

Point 1	Point 2	Point 3	Point 4	Point 5	Point 6	Point 7	Point 8	Point 9	Point 10	Point 11	Point 12	Point 13	Point 14
A	R	S	6	0	-								

Electrical interface	Mechanical interface	Connection type	Resolution
10 ... 32 V, SSI, Gray = A	Through hollow shaft ¹⁾ = D	Connector M23, 12 pin, radial = A	Any number of steps from 00002 up to 32,768 possible. Always 5 characters in clear text.
10 ... 32 V, SSI, Gray Excess = B	¹⁾ Collets for 6, 8, 10, 12 mm and 1/4", 3/8" and 1/2" as accessories, separate order item (see below).	Cable 11 core, radial 1.5 m = K	
		Cable 11 core, radial 3 m = L	
		Cable 11 core, radial 5 m = M	

Order example: Absolute Encoder Singleturn ARS 60 SSI

10 ... 32 V, SSI, Gray; through hollow shaft; connector M23, 12 pin, radial; number of steps 8,192

Point 1	Point 2	Point 3	Point 4	Point 5	Point 6	Point 7	Point 8	Point 9	Point 10	Point 11	Point 12	Point 13	Point 14
A	R	S	6	0	-	A	D	A	0	8	1	9	2

Please enter your individual encoder here

Point 1	Point 2	Point 3	Point 4	Point 5	Point 6	Point 7	Point 8	Point 9	Point 10	Point 11	Point 12	Point 13	Point 14
A	R	S	6	0	-								

Point 1	Point 2	Point 3	Point 4	Point 5	Point 6	Point 7	Point 8	Point 9	Point 10	Point 11	Point 12	Point 13	Point 14
A	R	S	6	0	-								

Point 1	Point 2	Point 3	Point 4	Point 5	Point 6	Point 7	Point 8	Point 9	Point 10	Point 11	Point 12	Point 13	Point 14
A	R	S	6	0	-								

Collets for blind hollow shaft encoder

Type	Part no.	Shaft diameter
SPZ-006-AD-D	2 029 192	6 mm
SPZ-1E4-AD-D	2 029 193	1/4"
SPZ-008-AD-D	2 029 194	8 mm
SPZ-3E8-AD-D	2 029 195	3/8"
SPZ-010-AD-D	2 029 196	10 mm
SPZ-012-AD-D	2 029 197	12 mm
SPZ-1E2-AD-D	2 029 198	1/2"

Order information Parallel Interface

Absolute Encoder Singleturn ARS 60 Parallel, through hollow shaft

Point 1	Point 2	Point 3	Point 4	Point 5	Point 6	Point 7	Point 8	Point 9	Point 10	Point 11	Point 12	Point 13	Point 14
A	R	S	6	0	-								

Electrical interface 10 ... 32 V, parallel, Gray = F 10 ... 32 V, parallel, Gray Exc. = G 10 ... 32 V, parallel, BIN = H 10 ... 32 V, parallel, BCD = J	Mechanical interface Through hollow shaft ¹⁾ = D <small>¹⁾ Collets for 6, 8, 10, 12 mm and 1/4", 3/8" and 1/2" as accessories, separate order item (see below).</small>	Connection type Connector M23, 21 pin, radial = A Cable 22 core, radial 1.5 m = K Cable 22 core, radial 3 m = L Cable 22 core, radial 5 m = M	Resolution Any number of steps from 00002 up to 32,768 possible, with the following electrical interfaces: 10 ... 32 V, parallel, Gray 10 ... 32 V, parallel, Gray Excess 10 ... 32 V, parallel, BIN Number of steps from 00002 up to 07999 possible, with the electrical interface: 10 ... 32 V, parallel, BCD Always 5 characters, in clear text.
--	---	--	---

Order example: Absolute Encoder Singleturn ARS 60 Parallel

10 ... 32 V, Parallel, Gray; through hollow shaft; connector M23, 21 pin, radial; number of steps 8,192

Point 1	Point 2	Point 3	Point 4	Point 5	Point 6	Point 7	Point 8	Point 9	Point 10	Point 11	Point 12	Point 13	Point 14
A	R	S	6	0	-	F	D	A	0	8	1	9	2

Please enter your individual encoder here

Point 1	Point 2	Point 3	Point 4	Point 5	Point 6	Point 7	Point 8	Point 9	Point 10	Point 11	Point 12	Point 13	Point 14
A	R	S	6	0	-								

Point 1	Point 2	Point 3	Point 4	Point 5	Point 6	Point 7	Point 8	Point 9	Point 10	Point 11	Point 12	Point 13	Point 14
A	R	S	6	0	-								

Point 1	Point 2	Point 3	Point 4	Point 5	Point 6	Point 7	Point 8	Point 9	Point 10	Point 11	Point 12	Point 13	Point 14
A	R	S	6	0	-								

Collets for blind hollow shaft encoder

Type	Part no.	Shaft diameter
SPZ-006-AD-D	2 029 192	6 mm
SPZ-1E4-AD-D	2 029 193	1/4"
SPZ-008-AD-D	2 029 194	8 mm
SPZ-3E8-AD-D	2 029 195	3/8"
SPZ-010-AD-D	2 029 196	10 mm
SPZ-012-AD-D	2 029 197	12 mm
SPZ-1E2-AD-D	2 029 198	1/2"

PIN and wire allocation

Allocation for encoder with 12 pin connector; SSI Interface

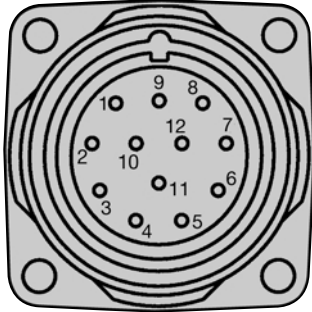

View of the connector M23 fitted to the encoder body SSI

Signal	12-pin connector	11-core cable outlet
GND	1	blue
Data (+)	2	white
Clock (+)	3	yellow
N. C.	4	–
CW/CCW	5	pink
N. C.	6	–
N. C.	7	–
U _s	8	red
SET	9	orange
Data (-)	10	brown
Clock (-)	11	violet
N. C.	12	–

Allocation for encoder with 21 pin connector Single; Parallel Interface

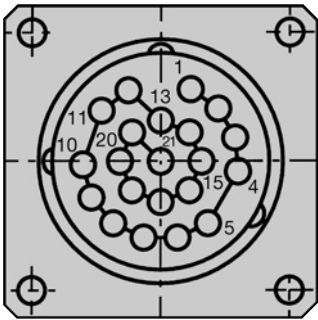

View of the connector M23 fitted to the encoder body Single, Parallel

PIN	Wire colour by cable outlet	Binary	Gray	BCD	Explanation
1	violet	2 ⁰	G ₀	2 ⁰ v.10 ⁰	Data lines, outputs
2	white/brown	2 ¹	G ₁	2 ¹ v.10 ⁰	
3	white/green	2 ²	G ₂	2 ² v.10 ⁰	
4	white/yellow	2 ³	G ₃	2 ³ v.10 ⁰	
5	white/grey	2 ⁴	G ₄	2 ⁰ v.10 ¹	
6	white/pink	2 ⁵	G ₅	2 ¹ v.10 ¹	
7	white/blue	2 ⁶	G ₆	2 ² v.10 ¹	
8	white/red	2 ⁷	G ₇	2 ³ v.10 ¹	
9	white/black	2 ⁸	G ₈	2 ⁰ v.10 ²	
10	brown/green	2 ⁹	G ₉	2 ¹ v.10 ²	
11	brown/yellow	2 ¹⁰	G ₁₀	2 ² v.10 ²	
12	brown/grey	2 ¹¹	G ₁₁	2 ³ v.10 ²	
13	brown/pink	2 ¹²	G ₁₂	2 ⁰ v.10 ³	
14	brown/blue	2 ¹³	G ₁₃	2 ¹ v.10 ³	
15	brown/red	2 ¹⁴	G ₁₄	2 ² v.10 ³	
16	green	Parity	Parity	Parity	
17	pink	Store ₋	Store ₋	Store ₋	
18	yellow	Enable ₋	Enable ₋	Enable ₋	
19	brown	CW/CCW ₋	CW/CCW ₋	CW/CCW ₋	
*)	grey	SET	SET	SET	
20	blue	GND	GND	GND	
21	red	U _s	U _s	U _s	
Housing		Screen	Screen	Screen	

* Set line only possible with a cable outlet

U _s	Supply voltage to the encoder (before commissioning, note must be taken of the type label of the encoder). Zero volt connection to the encoder: electrically isolated from the housing. The voltage referred to GND is U _s .	Enable ₋	This input activates the data output driver when a »LOW« level is applied. If not connected, this input is »LOW«. In the case of a »HIGH« level, the outputs are in the tristate mode.
GND			
CW/CCW ₋	Forward/reverse: this input programs the counting direction of the encoder. If not connected, this input is »HIGH«. If the encoder shaft, as viewed on the drive shaft, rotates in the clockwise direction, it counts in an increasing sequence. If it should count upwards when the shaft rotates in the anti-clockwise direction, this connection must be connected permanently to »LOW« level (zero volts).	Store ₋	This input stores the encoder data in Gray code when a »LOW« level is applied. This avoids a read error if the output data is requested in binary code. If this input is »LOW«, the data at the encoder output is stable, irrespective of whether the input shaft rotates. If not switched, this input is »HIGH«.
		Parity	This output supplies a »HIGH« level when the binary checksum of the data bits is even.
		SET	This input serves to set the zero electronically. If the SET line is connected to U _s for more than 100 ms, the mechanical position corresponds to the value 0.

Signal outputs

SSI Data format for resolutions ≤ 8,192 (1-13 bits)

In order to be compatible with the data formats on the market, a distinction is made in the ARS 60 between two data formats.

The first data format applies to the encoder designs with resolutions up to 13 bits.

This is the standard data format for the singleturn absolute encoder.

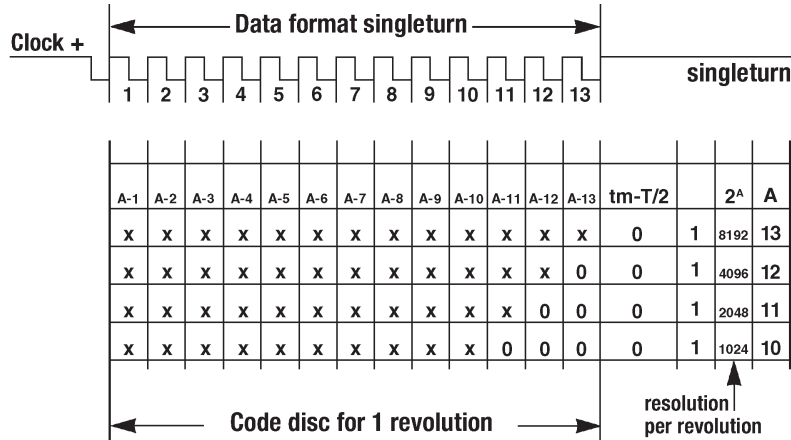

SSI Data format for resolutions > 8,192 (14 and 15 bits)

The data transmitted is left-justified. The 15 data bits are followed by two error bits.

Error 1 (E₁) = Position error

During the determination of the position, an error has occurred since the last SSI transmission.

This error bit will be deleted during the next SSI transmission.

Error 2 (E₂) = light source monitoring

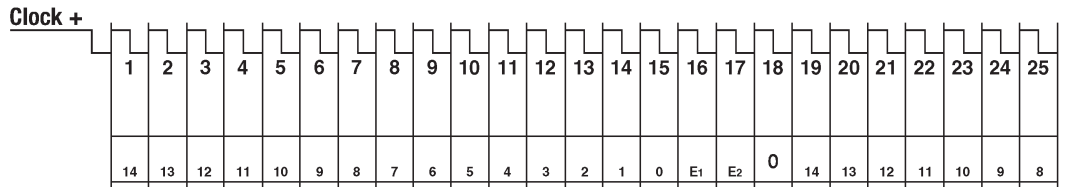

Parallel Interface (Output driver 7272 push-pull)

- Tristate capability
- Short-circuit protected
- Protected against reverse polarity
- Integrated transient protection diodes

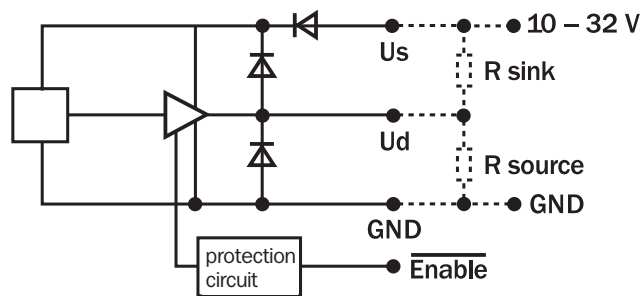

Technical Data: Parallel interface

Id_H max. at +85° C 8 nF 6000 min⁻¹			30 mA
Id_L max. at +85° C 8 nF 6000 min⁻¹			30 mA
Output saturation voltage (H-level)	to Id _H	10 mA	2.8 V
U _S -U _{dH}		30 mA	3.0 V
Output saturation voltage (L-level)	to Id _L	10 mA	0.4 V
U _{dL}		30 mA	2.0 V
Position refresh time (dependent upon the encoder resolution and output code)			
	Parallel Gray-Code		60 μs
	Parallel BIN-Code		60 μs
	Parallel BCD-Code		200 μs

Dimensional drawings and order information

Screw-in system M23, 12 pin

Female connector M23, 12 pin, straight, screened

Type	Part no.	Contacts
DOS-2312-G	6 027 538	12

Male connector M23, 12 pin, straight, screened

Type	Part no.	Contacts
STE-2312-G	6 027 537	12

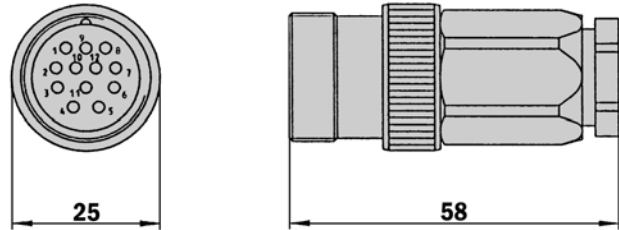
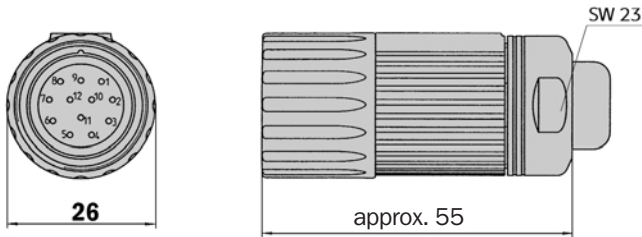

General tolerances according to DIN ISO 2768-mk

General tolerances according to DIN ISO 2768-mk

Female connector M23, 12 pin, straight, cable 12 pin, 4 x 2 x 0.25 + 2 x 0.5 + 2 x 0.14 mm² with screening, capable of being dragged, cable diameter 7.8 mm

Type	Part no.	Contacts	Cable length
DOL-2312-G1M5MA2	2 029 206	12	1.5 m
DOL-2312-G03MMA2	2 029 207	12	3.0 m
DOL-2312-G05MMA2	2 029 208	12	5.0 m
DOL-2312-G10MMA2	2 029 209	12	10.0 m
DOL-2312-G20MMA2	2 029 210	12	20.0 m
DOL-2312-G30MMA2	2 029 211	12	30.0 m

Cables

Cable 8 core, per meter, 4 x 2 x 0.15 mm² with screening, cable diameter 5.6 mm

Type	Part no.	Wires
LTG-2308-MWENC	6 027 529	8

Cable 11 core, per meter, 4 x 2 x 0.25 + 2 x 0.5 + 1 x 0.14 mm² with screening, cable diameter 7.5 mm

Type	Part no.	Wires
LTG-2411-MW	6 027 530	11

Cable 12 core, per meter, 4 x 2 x 0.25 + 2 x 0.5 + 2 x 0.14 mm²

with screening, capable of being dragged, cable diameter 7.8 mm

Type	Part no.	Wires	Explanation
LTG-2512-MW	6 027 531	12	
LTG-2612-MW	6 028 516	12	UV and salt water resistant

Dimensional drawings and order information

Screw-in system M23, 21 pin

Female connector M23, 21 pin, straight, screened, capable of being dragged

Type	Part no.	Contacts
DOS-2321-G	6 027 539	21

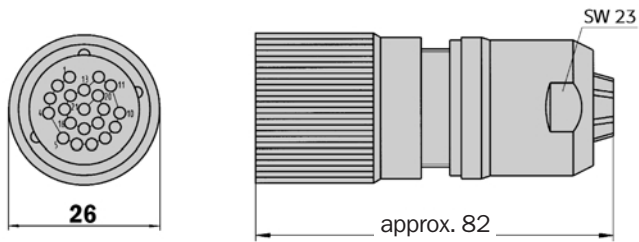

General tolerances according to DIN ISO 2768-mk

**Female connector M23, 21 pin, cable 22 core, 20 x 0.14 + 2 x 0.5 mm² with screening, capable of being dragged,
cable diameter 7.8 mm**

Type	Part no.	Contacts	Cable length
DOL-2321-G1M5PA4	2 029 218	21	1.5 m
DOL-2321-G03MPA4	2 029 219	21	3.0 m
DOL-2321-G05MPA4	2 029 220	21	5.0 m
DOL-2321-G10MPA4	2 029 221	21	10.0 m
DOL-2321-G20MPA4	2 029 222	21	20.0 m

Cables

**Cable 22 core, per meter, 20 x 0.14 + 2 x 0.5 mm² with screening,
cable diameter 7.8 mm**

Type	Part no.	Wires
LTG-2622-MW	6 027 532	22

Dimensional drawings and order information

Couplings

Bellows coupling, max. shaft offset radial ± 0.3 mm, axial 0.4 mm, angle ± 4 degrees, torsion spring stiffness 120 Nm/rad, bellows of stainless steel hubs of aluminium

Type	Part no.	Shaft diameter
KUP-0606-B	5 312 981	6 mm ... 6 mm
KUP-0610-B	5 312 982	6 mm ... 10 mm
KUP-1010-B	5 312 983	10 mm ... 10 mm
KUP-1012-B	5 312 984	10 mm ... 12 mm

Cheese-head screw
M2,5x8 DIN912 A2

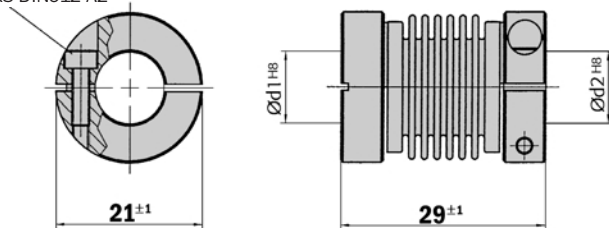

Spring-disc coupling, max. shaft offset radial ± 0.3 mm, axial 0.4 mm, angle ± 2.5 degrees, torsion spring stiffness 50 Nm/rad, flange of aluminium, spring-discs of glass-fibre-reinforced plastic

Type	Part no.	Shaft diameter
KUP-0610-F	5 312 985	6 mm ... 10 mm
KUP-1010-F	5 312 986	10 mm ... 10 mm

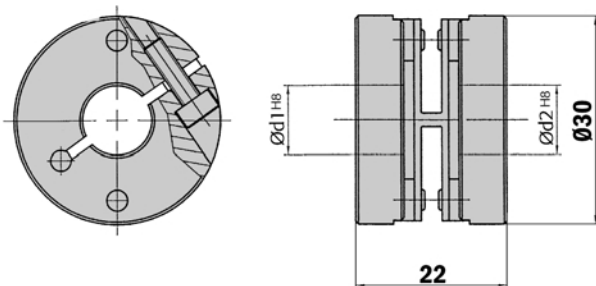

General tolerances according to DIN ISO 2768-mk

Dimensional drawings and order information

Servo clamps

Servo clamps half ring, Set (comprises 2 pieces) for servo flanges with spigot diameter 50 mm

Type	Part no.
BEF-WG-SF050	2 029 165

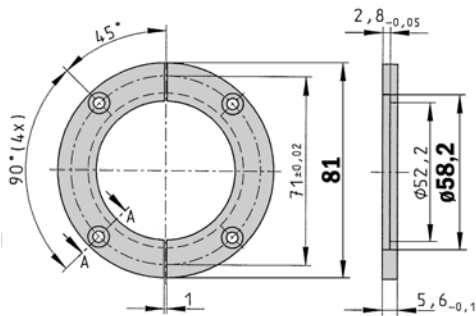

General tolerances according to DIN ISO 2768-mk

Servo clamps small, Set (comprises 3 pieces) for servo flanges

Type	Part no.
BEF-WK-SF	2 029 166

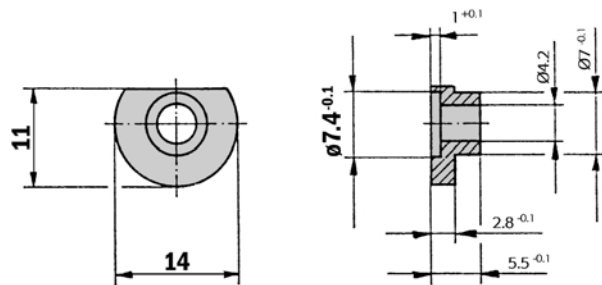

General tolerances according to DIN ISO 2768-mk

Mechanical Adaptors

Mounting bell incl. fixing set for encoder with servo flange

Type	Part no.	Flange spigot
BEF-MG-50	5 312 987	Diameter 50 mm

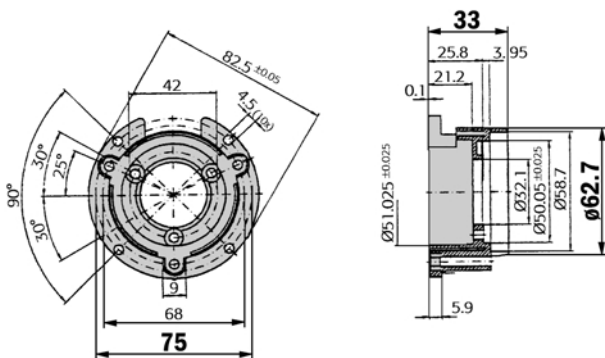

General tolerances according to DIN ISO 2768-mk

Mounting bell incl. fixing set for encoder with face mount flange

Type	Part no.	Flange spigot
BEF-WF-36	2 029 164	Diameter 36 mm

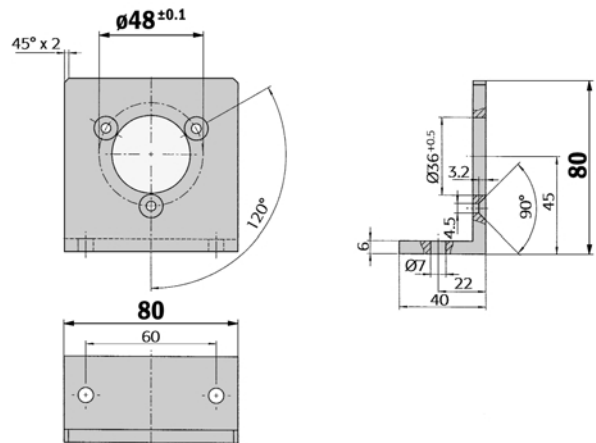

General tolerances according to DIN ISO 2768-mk

Dimensional drawings and order information

Mechanical Adaptors

Adaptor flange of aluminium for face mount flange, spigot 36 mm

Type	Part no.	Adaption
BEF-FA-036-050	2 029 160	To 50 mm Servo flange

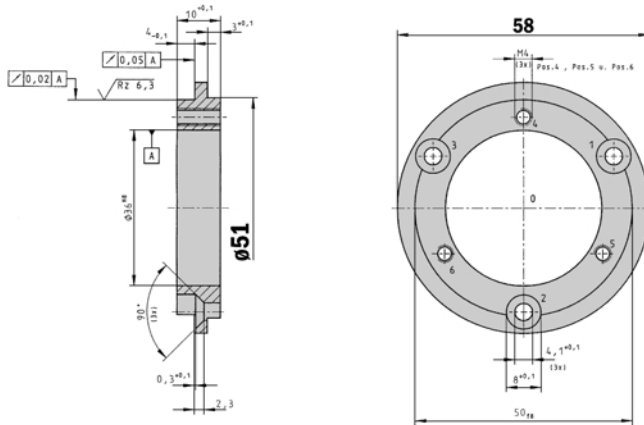

General tolerances according to DIN ISO 2768-mk

Adaptor flange of aluminium for face mount flange, spigot 36 mm

Type	Part no.	Adaption
BEF-FA-036-100	2 029 161	To 100 mm servo flange

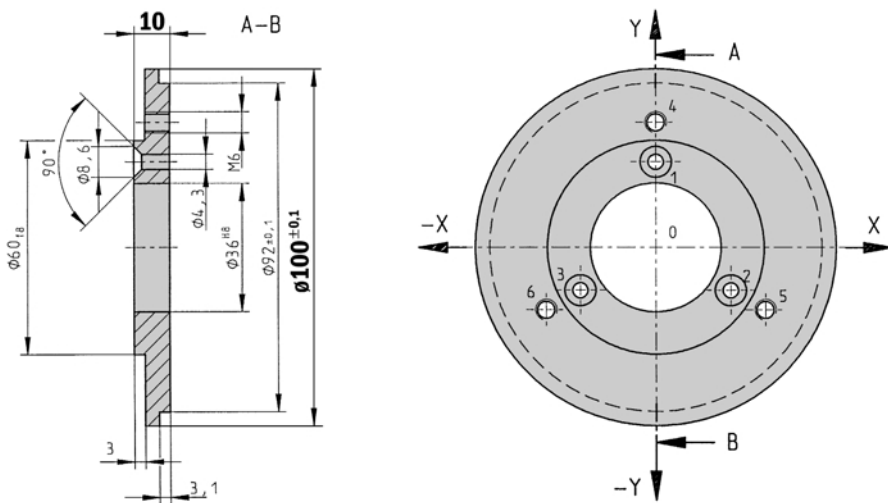

General tolerances according to DIN ISO 2768-mk

Dimensional drawings and order information

Mechanical Adaptors

Adaptor flange of aluminium for face mount flange spigot 36 mm

Type	Part no.	Adaption
BEF-FA-036-060REC	2 029 162	To 60 mm square mounting plate

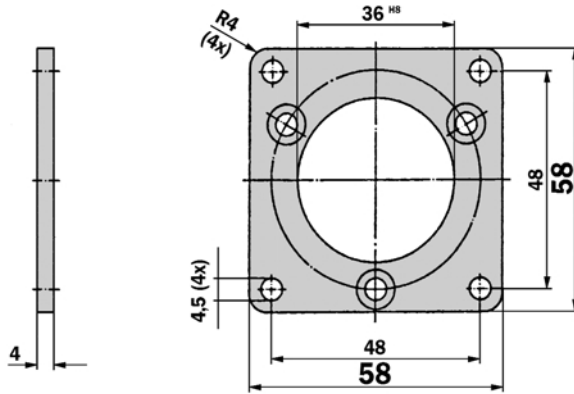

General tolerances according to DIN ISO 2768-mk

Adapter flange of aluminium for face mount flange, spigot 36 mm

Type	Part no.	Adaption
BEF-FA-036-060RSA	2 029 163	To 60 mm square mounting plate with shock absorbers

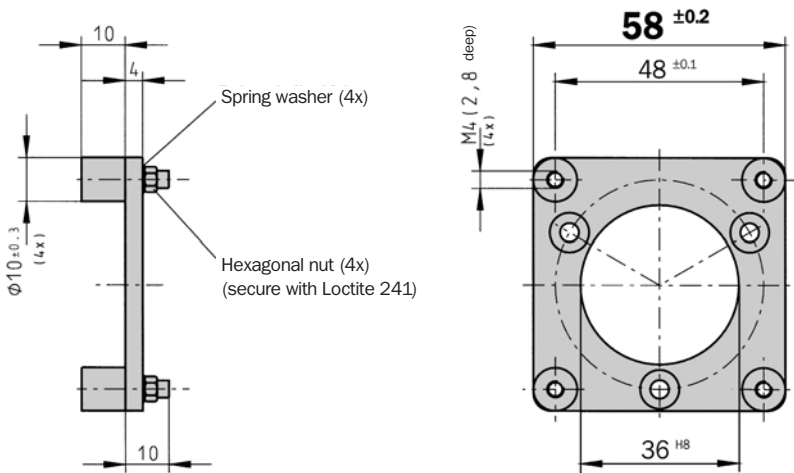

General tolerances according to DIN ISO 2768-mk

Dimensional drawings and order information

Collets

Collets for blind hollow shaft

Type	Part no.	Shaft diameter
SPZ-006-AD-A	2 029 174	6 mm
SPZ-1E4-AD-A	2 029 175	1/4"
SPZ-008-AD-A	2 029 176	8 mm
SPZ-3E8-AD-A	2 029 177	3/8"
SPZ-010-AD-A	2 029 178	10 mm
SPZ-012-AD-A	2 029 179	12 mm
SPZ-1E2-AD-A	2 029 180	1/2"

Collets for through hollow shaft

Type	Part no.	Shaft diameter
SPZ-006-AD-D	2 029 192	6 mm
SPZ-1E4-AD-D	2 029 193	1/4"
SPZ-008-AD-D	2 029 194	8 mm
SPZ-3E8-AD-D	2 029 195	3/8"
SPZ-010-AD-D	2 029 196	10 mm
SPZ-012-AD-D	2 029 197	12 mm
SPZ-1E2-AD-D	2 029 198	1/2"

Adaptor modules for SSI Interface

Serial-Parallel Adaptor modules

Type	Part no.	Description
AD-SSIG-PA	1 030 106	SSI-Parallel Adaptor module in plastic housing
AD-SSI-PA	1 030 107	SSI-Parallel Adaptor module without plastic housing
AD-SSIPG-PA	1 030 108	SSI-Parallel Adaptor module, programmable, in plastic housing
AD-SSIPF-PA	1 030 109	SSI-Parallel Adaptor module programmable, without plastic housing, with front plate
AD-SSIP-PA	1 030 110	SSI-Parallel Adaptor module programmable, without plastic housing, without front plate

Screw-in systems Sub-D for Adaptor modules

Male connector Sub-D, 15 pin, straight, screened

Type	Part no.	Contacts
STE-0D15-G	2 029 223	15

Female connector Sub-D, 37 pin, straight, screened

Type	Part no.	Contacts
DOS-0D37-G	2 029 224	37

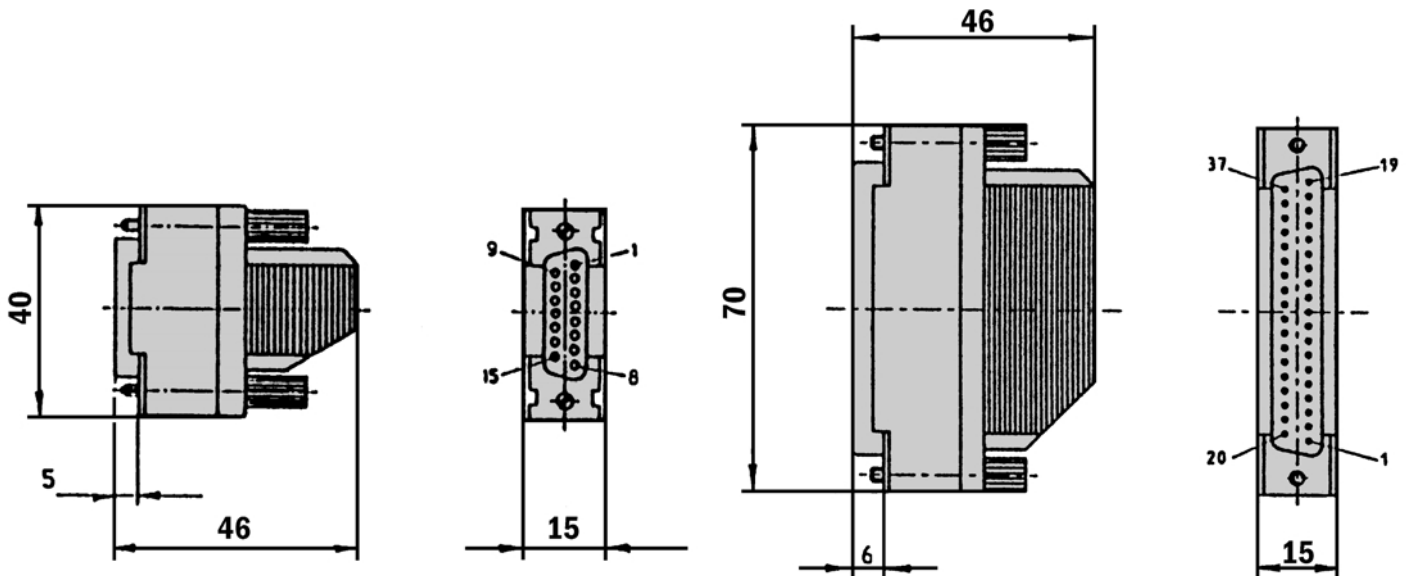

General tolerances according to DIN ISO 2768-mk

General tolerances according to DIN ISO 2768-mk

Contact:

Australia

Phone +61 3 9497 4100
1800 33 48 02 – tollfree
E-Mail sales@sick.com.au

Belgium / Luxembourg

Phone +32 (0)2 466 55 66
E-Mail info@sick.be

Brasil

Phone +55 11 5091-4900
E-Mail sac@sick.com.br

Ceská Republika

Phone +420 2 57 91 18 50
E-Mail sick@sick.cz

China

Phone +852-2763 6966
E-Mail ghk@sick.com.hk

Danmark

Phone +45 45 82 64 00
E-Mail sick@sick.dk

Deutschland

Phone +49 (0)2 11 53 01-250
E-Mail info@sick.de

España

Phone +34 93 480 31 00
E-Mail info@sick.es

France

Phone +33 1 64 62 35 00
E-Mail info@sick.fr

Great Britain

Phone +44 (0)1727 831121
E-Mail info@sick.co.uk

India

Phone +91 (11)2696 7651
E-Mail ayograj@tecnovaglobal.com

Italia

Phone +39 011 79 79 65
E-Mail info@sick.it

Japan

Phone +81 (0)3 3358 1341
E-Mail info@sick.jp

Korea

Phone +82-2 786 6321/4
E-Mail kang@sickkorea.net

Netherlands

Phone +31 (0)30 229 25 44
E-Mail info@sick.nl

Norge

Phone +47 67 81 50 00
E-Mail austefjord@sick.no

Österreich

Phone +43 (0)22 36 62 28 8-0
E-Mail office@sick.at

Polska

Phone +48 22 837 40 50
E-Mail info@sick.pl

Republika Slovenija

Phone +386 (0)1-47 69 990
E-Mail selanm@sick.com

Russia

Phone +7 95 775 05 30
E-Mail info@sick-automation.ru

Schweiz

Phone +41 41 619 29 39
E-Mail contact@sick.ch

Singapore

Phone +65 6744 3732
E-Mail admin@sicksgp.com.sg

Suomi

Phone +358-9-25 15 800
E-Mail sick@sick.fi

Sverige

Phone +46 8 680 64 50
E-Mail info@sick.se

Türkiye

Phone +90 216 388 95 90 pbx
E-Mail info@sick.com.tr

Taiwan

Phone +886 2 2365-6292
E-Mail sickgrc@ms6.hinet.net

USA

Phone +1 937-454-1956
E-Mail sales@stegmann.com

More representatives and agencies
in all major industrial nations at
www.sick.com

SICK | STEGMANN

SICK AG • Industrial Sensors • Waldkirch • Germany • www.sick.com
SICK STEGMANN GmbH • Donaueschingen • Germany • www.sick-stegmann.de