



# PowerFlex® 40P Adjustable Frequency AC Drive

Quick Start

## FRN 1.xx - 3.xx

This Quick Start guide summarizes the basic steps needed to install, start-up and program the PowerFlex 40P Adjustable Frequency AC Drive. **The information provided Does Not replace the User Manual and is intended for qualified drive service personnel only.** For detailed PowerFlex 40P information including EMC instructions, application considerations and related precautions, refer to the PowerFlex 40P *User Manual*, Publication 22D-UM001... at [www.rockwellautomation.com/literature](http://www.rockwellautomation.com/literature).

## General Precautions

---



**ATTENTION:** The drive contains high voltage capacitors which take time to discharge after removal of mains supply. Before working on drive, ensure isolation of mains supply from line inputs [R, S, T (L1, L2, L3)]. Wait three minutes for capacitors to discharge to safe voltage levels. Failure to do so may result in personal injury or death.

Darkened display LEDs is not an indication that capacitors have discharged to safe voltage levels.

**ATTENTION:** Equipment damage and/or personal injury may result if parameter A092 [Auto Rstrt Tries] or A094 [Start At PowerUp] is used in an inappropriate application. Do not use this function without considering applicable local, national and international codes, standards, regulations or industry guidelines.

**ATTENTION:** Only qualified personnel familiar with adjustable frequency AC drives and associated machinery should plan or implement the installation, start-up and subsequent maintenance of the system. Failure to comply may result in personal injury and/or equipment damage.

**ATTENTION:** This drive contains ESD (Electrostatic Discharge) sensitive parts and assemblies. Static control precautions are required when installing, testing, servicing or repairing this assembly. Component damage may result if ESD control procedures are not followed. If you are not familiar with static control procedures, reference A-B publication 8000-4.5.2, "Guarding Against Electrostatic Damage" or any other applicable ESD protection handbook.

**ATTENTION:** An incorrectly applied or installed drive can result in component damage or a reduction in product life. Wiring or application errors, such as, undersizing the motor, incorrect or inadequate AC supply, or excessive ambient temperatures may result in malfunction of the system.

**ATTENTION:** Risk of injury or equipment damage exists. Drive does not contain user-serviceable components. Do not disassemble drive chassis.

---

## Mounting Considerations

- Mount the drive upright on a flat, vertical and level surface.

Frame	Screw Size	Screw Torque	DIN Rail
B	M4 (#8-32)	1.56-1.96 N-m (14-17 lb.-in.)	35 mm
C	M5 (#10-24)	2.45-2.94 N-m (22-26 lb.-in.)	–

- Protect the cooling fan by avoiding dust or metallic particles.
- Do not expose to a corrosive atmosphere.
- Protect from moisture and direct sunlight.

### Minimum Mounting Clearances

See page 21 for mounting dimensions.

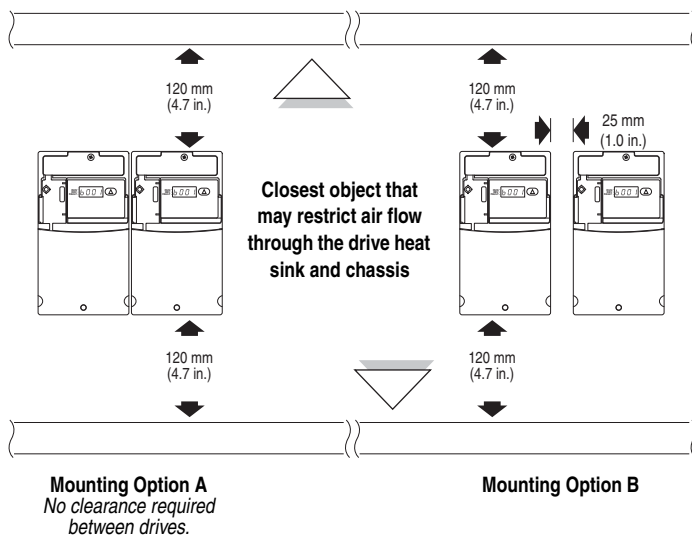

### Ambient Operating Temperatures

Ambient Temperature		Enclosure Rating	Minimum Mounting Clearances
Minimum	Maximum		
-10°C (14°F)	40°C (104°F)	IP 20/Open Type	Use Mounting Option A
		IP 30/NEMA 1/UL Type 1 <sup>(1)</sup>	Use Mounting Option B
	50°C (122°F)	IP 20/Open Type	Use Mounting Option B

<sup>(1)</sup> Rating requires installation of the PowerFlex 40P IP 30/NEMA 1/UL Type 1 option kit.

## Typical Grounding

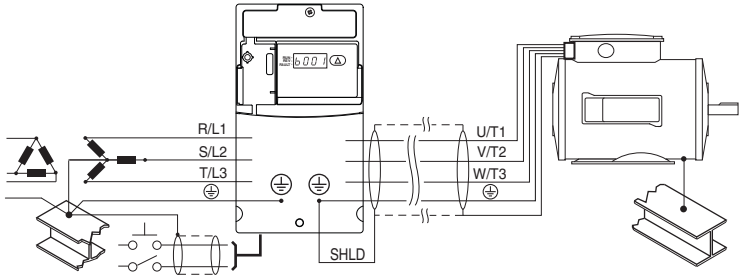

## Disconnecting MOVs

To prevent drive damage, the MOVs connected to ground shall be disconnected if the drive is installed on an ungrounded distribution system where the line-to-ground voltages on any phase could exceed 125% of the nominal line-to-line voltage. To disconnect these devices, remove the jumper shown in the figures below.

1. Turn the screw counterclockwise to loosen.
2. Pull the jumper completely out of the drive chassis.
3. Tighten the screw to keep it in place.

### Jumper Location

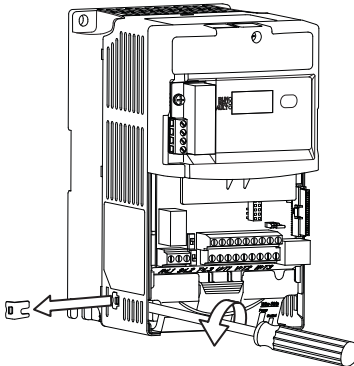

### Phase to Ground MOV Removal

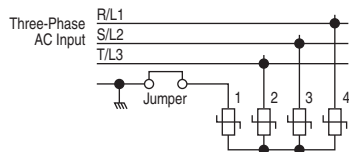

**Important:** Tighten screw after jumper removal.

## CE Conformity

Refer to the PowerFlex 40P *User Manual* for details on how to comply with the Low Voltage (LV) and Electromagnetic Compatibility (EMC) Directives.

## Specifications, Fuses and Circuit Breakers

### Drive Ratings





Catalog Number <sup>(1)</sup>	Output Ratings		Input Ratings			Branch Circuit Protection			
	kW (HP)	Amps	Voltage Range	kVA	Amps	Fuses	140M Motor Protectors <sup>(2)</sup> (3)	Contactors	Min. Enclosure Volume <sup>(4)</sup> (in. <sup>3</sup> )
<b>200 - 240V AC (±10%) – 3-Phase Input, 0 - 230V 3-Phase Output</b>									
22D-B2P3	0.4 (0.5)	2.3	180-264	1.15	2.5	6	140M-C2E-B40	100-C07	1655
22D-B5P0	0.75 (1.0)	5.0	180-264	2.45	5.7	10	140M-C2E-C10	100-C09	1655
22D-B8P0	1.5 (2.0)	8.0	180-264	4.0	9.5	15	140M-C2E-C16	100-C12	1655
22D-B012	2.2 (3.0)	12.0	180-264	5.5	15.5	25	140M-C2E-C16	100-C23	1655
22D-B017	3.7 (5.0)	17.5	180-264	8.6	21.0	30	140M-F8E-C25	100-C23	1655
22D-B024	5.5 (7.5)	24.0	180-264	11.8	26.1	40	140M-F8E-C32	100-C37	2069
22D-B033	7.5 (10.0)	33.0	180-264	16.3	34.6	60	140M-G8E-C45	100-C60	2069
<b>380 - 480V AC (±10%) – 3-Phase Input, 0 - 460V 3-Phase Output</b>									
22D-D1P4	0.4 (0.5)	1.4	342-528	1.4	1.8	3	140M-C2E-B25	100-C07	1655
22D-D2P3	0.75 (1.0)	2.3	342-528	2.3	3.2	6	140M-C2E-B40	100-C07	1655
22D-D4P0	1.5 (2.0)	4.0	342-528	4.0	5.7	10	140M-C2E-B63	100-C09	1655
22D-D6P0	2.2 (3.0)	6.0	342-528	5.9	7.5	15	140M-C2E-C10	100-C09	1655
22D-D010	4.0 (5.0)	10.5	342-528	10.3	13.0	20	140M-C2E-C16	100-C23	1655
22D-D012	5.5 (7.5)	12.0	342-528	11.8	14.2	25	140M-D8E-C20	100-C23	2069
22D-D017	7.5 (10.0)	17.0	342-528	16.8	18.4	30	140M-D8E-C20	100-C23	2069
22D-D024	11.0 (15.0)	24.0	342-528	23.4	26.0	50	140M-F8E-C32	100-C43	2069
<b>460 - 600V AC (±10%) – 3-Phase Input, 0 - 575V 3-Phase Output</b>									
22D-E1P7	0.75 (1.0)	1.7	414-660	2.1	2.3	6	140M-C2E-B25	100-C09	1655
22D-E3P0	1.5 (2.0)	3.0	414-660	3.65	3.8	6	140M-C2E-B40	100-C09	1655
22D-E4P2	2.2 (3.0)	4.2	414-660	5.2	5.3	10	140M-D8E-B63	100-C09	1655
22D-E6P6	4.0 (5.0)	6.6	414-660	8.1	8.3	15	140M-D8E-C10	100-C09	1655
22D-E9P9	5.5 (7.5)	9.9	414-660	12.1	11.2	20	140M-D8E-C16	100-C16	2069
22D-E012	7.5 (10.0)	12.2	414-660	14.9	13.7	25	140M-D8E-C16	100-C23	2069
22D-E019	11.0 (15.0)	19.0	414-660	23.1	24.1	40	140M-F8E-C25	100-C30	2069

(1) Ratings apply to all drive types; Panel Mount (N104), Flange Mount (F104), and Plate Drive (H204).

(2) The AIC ratings of the Bulletin 140M Motor Protector Circuit Breakers may vary. See [Bulletin 140M Motor Protection Circuit Breakers Application Ratings](#).

(3) Manual Self-Protected (Type E) Combination Motor Controller, UL listed for 208 Wye or Delta, 240 Wye or Delta, 480Y/277 or 600Y/347. Not UL listed for use on 480V or 600V Delta/Delta, corner ground, or high-resistance ground systems.

(4) When using a Manual Self-Protected (Type E) Combination Motor Controller, the drive must be installed in a ventilated or non-ventilated enclosure with the minimum volume specified in this column. Application specific thermal considerations may require a larger enclosure.

Category	Specification	
Agency Certification	 Listed to UL508C and CAN/CSA-22.2	
	 Certified to AS/NZS, 1997 Group 1, Class A	
	 Marked for all applicable European Directives EMC Directive (89/336) EN 61800-3, EN 50081-1, EN 50082-2 Low Voltage Directive (73/23/EEC) EN 50178, EN 60204	
	 Certified to ISO 13849-1; Performance Level d (Safety Category 3). Meets Functional Safety (FS) when used with the DriveGuard Safe-Off Option (Series B).	
	The drive is also designed to meet the appropriate portions of the following specifications: NFPA 70 - US National Electrical Code NEMA ICS 3.1 - Safety standards for Construction and Guide for Selection, Installation and Operation of Adjustable Speed Drive Systems. IEC 146 - International Electrical Code.	
Protection	Bus Overvoltage Trip 200-240V AC Input: 380-460V AC Input: 460-600V AC Input:	405V DC bus (equivalent to 290V AC incoming line) 810V DC bus (equivalent to 575V AC incoming line) 1005V DC bus (equivalent to 711V AC incoming line)
	Bus Undervoltage Trip 200-240V AC Input: 380-480V AC Input: 460-600V AC Input P042 = 3 "High Voltage": P042 = 2 "Low Voltage":	210V DC bus (equivalent to 150V AC incoming line) 390V DC bus (equivalent to 275V AC incoming line) 487V DC bus (equivalent to 344V AC incoming line) 390V DC bus (equivalent to 275V AC incoming line)
	Power Ride-Thru:	100 milliseconds
	Logic Control Ride-Thru:	0.5 seconds minimum, 2 seconds typical
	Electronic Motor Overload Protection:	Provides class 10 motor overload protection according to NEC article 430 and motor over-temperature protection according to NEC article 430.126 (A) (2). UL 508C File 29572.
	Overcurrent:	200% hardware limit, 300% instantaneous fault
	Ground Fault Trip:	Phase-to-ground on drive output
	Short Circuit Trip:	Phase-to-phase on drive output
Environment	Altitude:	1000 m (3300 ft) max. without derating. Above 1000 m (3300 ft) derate 3% for every 305 m (1000 ft).
	Maximum Surrounding Air Temperature without derating: IP20, Open Type: IP30, NEMA Type 1, UL Type 1: Flange and Plate Mount:	-10 to 50° C (14 to 122° F) -10 to 40° C (14 to 104° F) Heatsink: -10 to 40° C (14 to 104° F) Drive: -10 to 50° C (14 to 122° F)
	Cooling Method Convection: Fan:	0.4 kW (0.5 HP) drives and all Flange and Plate drives All other drive ratings
	Storage Temperature:	-40 to 85 degrees C (-40 to 185 degrees F)
	Atmosphere:	<b>Important:</b> Drive <b>must not</b> be installed in an area where the ambient atmosphere contains volatile or corrosive gas, vapors or dust. If the drive is not going to be installed for a period of time, it must be stored in an area where it will not be exposed to a corrosive atmosphere.
	Relative Humidity:	0 to 95% non-condensing
	Shock (operating):	15G peak for 11ms duration (±1.0 ms)
	Vibration (operating):	1G peak, 5 to 2000 Hz

## English-6

Category	Specification		
Electrical	Voltage Tolerance:	200-240V $\pm 10\%$ 380-480V $\pm 10\%$ 460-600V $\pm 10\%$	
	Frequency Tolerance:	48-63 Hz	
	Input Phases:	Three-phase input provides full rating. Single-phase operation provides 35% rated current.	
	Displacement Power Factor:	0.98 across entire speed range	
	Maximum Short Circuit Rating:	100,000 Amps Symmetrical	
	Actual Short Circuit Rating:	Determined by AIC Rating of installed fuse/circuit breaker	
	Transistor Type:	Isolated Gate Bipolar (IGBT)	
Control	Method:	Sinusoidal PWM, Volts/Hertz, and Sensorless Vector	
	Carrier Frequency	2-16 kHz, Drive rating based on 4 kHz.	
	Frequency Accuracy		
	Digital Input:	Within $\pm 0.05\%$ of set output frequency	
	Analog Input:	Within 0.5% of maximum output frequency, 10-Bit resolution	
	Analog Output:	$\pm 2\%$ of full scale, 10-Bit resolution	
	Speed Regulation		
	Open Loop with Slip Compensation:	$\pm 1\%$ of base speed across a 80:1 speed range	
	With Encoder:	$\pm 0.3\%$ of base speed across a 80:1 speed range $\pm 0.05\%$ of base speed across a 20:1 speed range	
	Output Frequency:	0-500 Hz (programmable)	
	Efficiency:	97.5% (typical)	
Stop Modes:	Multiple programmable stop modes including - Ramp, Coast, DC-Brake, and Ramp-to-Stop		
Accel/Decel:	Four independently programmable accel and decel times. Each time may be programmed from 0 - 600 seconds in 0.1 second increments.		
Intermittent Overload:	150% Overload capability for up to 1 minute 200% Overload capability for up to 3 seconds		
Electronic Motor Overload Protection	Provides class 10 motor overload protection according to NEC article 430 and motor over-temperature protection according to NEC article 430.126 (A) (2). UL 508C File 29572.		
Control Inputs	Digital:	Bandwidth:	10 Rad/Secs for open and closed loop
		Quantity:	(2) Semi-programmable (5) Programmable
		Current:	6 mA
		Type	
	Source Mode (SRC):	18-24V = ON, 0-6V = OFF	
	Sink Mode (SNK):	0-6V = ON, 18-24V = OFF	
Analog:	Quantity:	(2) Isolated, $-10$ to 10V and 4-20mA	
	Specification		
Resolution:	10-bit		
0 to 10V DC Analog:	100k ohm input impedance		
4-20mA Analog:	250 ohm input impedance		
External Pot:	1-10k ohm, 2 Watt minimum		
Encoder	Type:	Incremental, dual channel	
	Supply:	12V, 250 mA. 12V, 10 mA minimum inputs isolated with differential transmitter, 250 kHz maximum.	
	Quadrature:	90°, $\pm 27$ degrees at 25 degrees C.	
	Duty Cycle:	50%, $+10\%$	
	Requirements:	Encoders must be line driver type, quadrature (dual channel) or pulse (single channel), 3.5-26V DC output, single-ended or differential and capable of supplying a minimum of 10 mA per channel. Allowable input is DC up to a maximum frequency of 250 kHz. The encoder I/O automatically scales to allow 5V, 12V and 24V DC nominal voltages.	

Category	Specification		
Control Outputs	Relay:	Quantity:	(1) Programmable Form C
		Specification	
	Resistive Rating:	3.0A at 30V DC, 3.0A at 125V, 3.0A at 240V AC	
		Inductive Rating:	0.5A at 30V DC, 0.5A at 125V, 0.5A at 240V AC
	Opto:	Quantity:	(2) Programmable
		Specification:	30V DC, 50mA Non-inductive
Analog:	Quantity:	(1) Non-Isolated 0-10V or 4-20mA	
	Specification		
	Resolution:	10-bit	
	0 to 10V DC Analog:	1k ohm minimum	
	4-20mA Analog:	525 ohm maximum	

## Power Wiring

Power Wire Rating	Recommended Copper Wire
Unshielded 600V, 75°C (167°F) THHN/THWN	15 Mils insulated, dry location
Shielded 600V, 75°C or 90°C (167°F or 194°F) RHH/RHW-2	Anixter OLF-7xxxxx, Belden 29501-29507 or equivalent
Shielded Tray rated 600V, 75°C or 90°C (167°F or 194°F) RHH/RHW-2	Anixter 7V-7xxxx-3G Shawflex 2ACD/3ACD or equivalent

### Power Terminal Block

#### B Frame

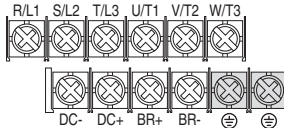

#### C Frame

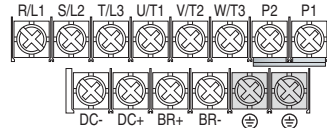

Terminal <sup>(1)</sup>	Description
R/L1, S/L2	1-Phase Input <sup>(2)</sup>
R/L1, S/L2, T/L3	3-Phase Input
U/T1	To Motor U/T1
V/T2	To Motor V/T2
W/T3	To Motor W/T3
	DC Bus Inductor Connection (C Frame drives only.)
P2, P1	The C Frame drive is shipped with a jumper between Terminals P2 and P1. Remove this jumper only when a DC Bus Inductor will be connected. Drive will not power up without a jumper or inductor connected. 
DC+, DC-	DC Bus Connection
BR+, BR-	Dynamic Brake Resistor Connection
⊕	Safety Ground - PE



Switch any two motor leads to change forward direction.

- (1) **Important:** Terminal screws may become loose during shipment. Ensure that all terminal screws are tightened to the recommended torque before applying power to the drive.
- (2) Single-phase operation requires a 65% derate of drive rated current.

**Power Terminal Block Specifications**

Frame	Maximum Wire Size <sup>(1)</sup>	Minimum Wire Size <sup>(1)</sup>	Torque
B	5.3 mm <sup>2</sup> (10 AWG)	1.3 mm <sup>2</sup> (16 AWG)	1.7-2.2 N-m (16-19 lb.-in.)
C	8.4 mm <sup>2</sup> (8 AWG)	1.3 mm <sup>2</sup> (16 AWG)	2.9-3.7 N-m (26-33 lb.-in.)

<sup>(1)</sup> Maximum/minimum sizes that the terminal block will accept - these are not recommendations.

**Input Power Conditions**

Input Power Condition	Corrective Action
Low Line Impedance (less than 1% line reactance)	<ul style="list-style-type: none"> <li>• Install Line Reactor<sup>(2)</sup></li> <li>• or Isolation Transformer</li> <li>• or Bus Inductor – 5.5 &amp; 11 kW (7.5 &amp; 15 HP) drives only</li> </ul>
Greater than 120 kVA supply transformer	
Line has power factor correction capacitors	<ul style="list-style-type: none"> <li>• Install Line Reactor</li> <li>• or Isolation Transformer</li> </ul>
Line has frequent power interruptions	
Line has intermittent noise spikes in excess of 6000V (lightning)	
Phase to ground voltage exceeds 125% of normal line to line voltage	<ul style="list-style-type: none"> <li>• Remove MOV jumper to ground.</li> <li>• or Install Isolation Transformer with grounded secondary if necessary.</li> </ul>
Ungrounded distribution system	
240V open delta configuration (stinger leg) <sup>(1)</sup>	<ul style="list-style-type: none"> <li>• Install Line Reactor</li> </ul>

<sup>(1)</sup> For drives applied on an open delta with a middle phase grounded neutral system, the phase opposite the phase that is tapped in the middle to the neutral or earth is referred to as the “stinger leg,” “high leg,” “red leg,” etc. This leg should be identified throughout the system with red or orange tape on the wire at each connection point. The stinger leg should be connected to the center Phase B on the reactor. Refer to the PowerFlex 40P *User Manual* for specific line reactor part numbers.

<sup>(2)</sup> Refer to Appendix B of the PowerFlex 40P *User Manual* for accessory ordering information.

**Common Bus/Precharge Notes**

If drives with internal precharge are used with a disconnect switch to the common bus, then an auxiliary contact on the disconnect must be connected to a digital input of the drive. The corresponding input (parameter A051-A054) must be set to option 29, “Precharge Enable.” This provides the proper precharge interlock, guarding against possible damage to the drive when connected to a common DC bus.



## I/O Wiring Recommendations

### Signal and Control Wire Types

Signal Type/ Where Used	Belden Wire Type(s) <sup>(1)</sup> (or equivalent)	Description	Min. Insulation Rating
Analog I/O & PTC	8760/9460	0.750 mm <sup>2</sup> (18 AWG), twisted pair, 100% shield with drain <sup>(3)</sup>	300V, 75-90° C (167-194° F)
Remote Pot	8770	0.750 mm <sup>2</sup> (18 AWG), 3 cond., shielded	
Encoder/Pulse I/O	89730 <sup>(2)</sup>	0.196 mm <sup>2</sup> (24 AWG), individually shielded pairs	

(1) Stranded or solid wire.

(2) 9728 or 9730 are equivalent and may be used but may not fit in the drive wire channel.

(3) If the wires are short and contained within a cabinet which has no sensitive circuits, the use of shielded wire may not be necessary, but is always recommended.

### Recommended Control Wire for Digital I/O

Type	Wire Type(s)	Description	Minimum Insulation Rating
Unshielded	Per US NEC or applicable national or local code	–	300V, 60 degrees C (140 degrees F)
Shielded	Multi-conductor shielded cable such as Belden 8770 (or equiv.)	0.750 mm <sup>2</sup> (18 AWG), 3 conductor, shielded.	

### I/O Terminal Block Specifications

Frame	Maximum Wire Size <sup>(1)</sup>	Minimum Wire Size <sup>(1)</sup>	Torque
B & C	1.3 mm <sup>2</sup> (16 AWG)	0.2 mm <sup>2</sup> (24 AWG)	0.5-0.8 N-m (4.4-7 lb.-in.)

(1) Maximum/minimum sizes that the terminal block will accept - these are not recommendations.

Refer to the PowerFlex 40P *User Manual* for recommendations on maximum power and control cable length.

# Control Terminal Block

## Control Wiring Block Diagram

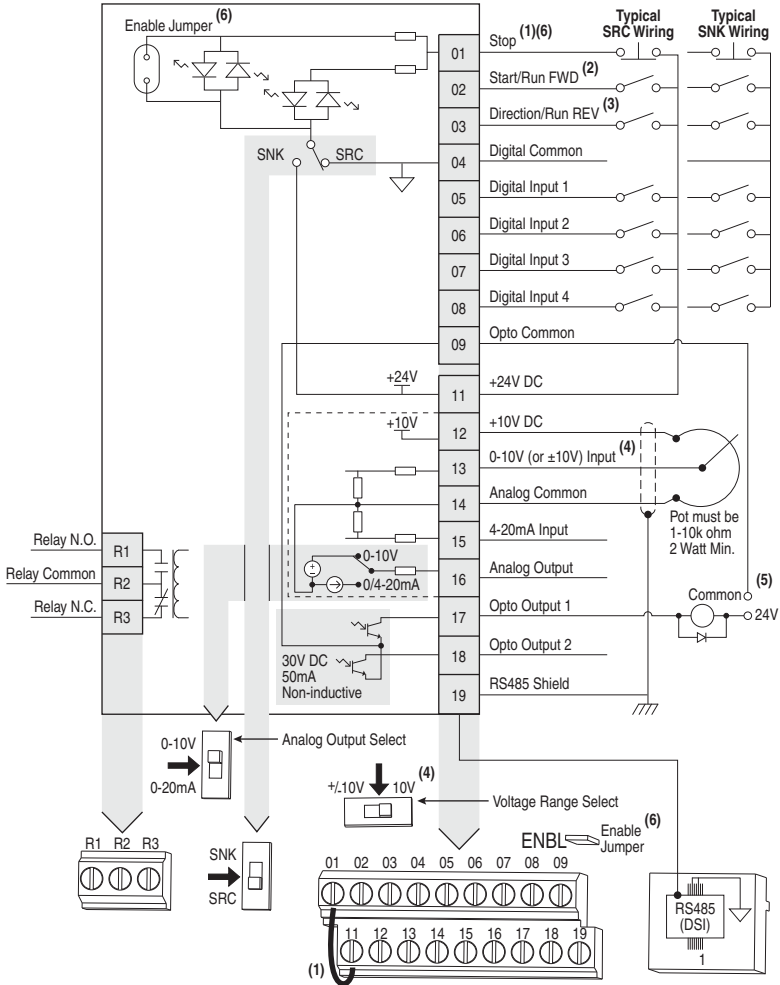

	30V DC	125V AC	240V AC
Resistive	3.0A	3.0A	3.0A
Inductive	0.5A	0.5A	0.5A

See Control Wiring Block Diagram Notes on next page.



---

**Control Wiring Block Diagram Notes**

- (1) **Important:** I/O Terminal 01 is always a coast to stop input except when P036 [Start Source] is set to "3-Wire", "2-W Lvl Sens" or "Momt FWD/REV" control. In three wire control, I/O Terminal 01 is controlled by P037 [Stop Mode]. All other stop sources are controlled by P037 [Stop Mode].

P036 [Start Source]	Stop	I/O Terminal 01 Stop
3-Wire	Per P037	Per P037 <sup>(6)</sup>
2-Wire	Per P037	Coast
2-W Lvl Sens	Per P037	Per P037 <sup>(6)</sup>
2-W Hi Speed	Per P037	Coast
RS485 Port	Per P037	Coast
Momt FWD/REV	Per P037	Per P037 <sup>(6)</sup>

**Important:** The drive is shipped with a jumper installed between I/O Terminals 01 and 11. Remove this jumper when using I/O Terminal 01 as a stop or enable input.

- (2) Two wire control shown. For three wire control use a momentary input  on I/O Terminal 02 to command a start. Use a maintained input  for I/O Terminal 03 to change direction.
- (3) The function of I/O Terminal 03 is fully programmable. Program with E202 [Digital Term 3].
- (4) Match the Voltage Range Select DIP switch setting with the control scheme for proper Uni-Polar or Bipolar operation.
- (5) When using an opto output with an inductive load such as a relay, install a recovery diode parallel to the relay as shown, to prevent damage to the output.
- (6) When the ENBL enable jumper is removed, I/O Terminal 01 will always act as a hardware enable, causing a coast to stop without software interpretation.

## Control I/O Terminal Designations

No.	Signal	Default	Description	Param.
R1	Relay N.O.	Fault	Normally open contact for output relay.	A055
R2	Relay Common	–	Common for output relay.	
R3	Relay N.C.	Fault	Normally closed contact for output relay.	A055
Analog Output Select DIP Switch		0-10V	Sets analog output to either voltage or current. Setting must match A065 [Analog Out Sel].	
Sink/Source DIP Switch		Source (SRC)	Inputs can be wired as Sink (SNK) or Source (SRC) via DIP Switch setting.	
01	Stop <sup>(1)</sup>	Coast	The factory installed jumper or a normally closed input must be present for the drive to start.	P036 <sup>(1)</sup>
02	Start/Run FWD	Not Active	I/O Terminal 03 is fully programmable. Program with E202 [Digital Term 3]. To disable reverse operation, see A095 [Reverse Disable].	P036, P037
03	Digital Term 3	Not Active		P036, P037, A095, E202
04	Digital Common	–	For digital inputs. Electronically isolated with digital inputs from analog I/O and opto outputs.	
05	Digital Input 1	Preset Freq	Program with A051 [Digital In1 Sel].	A051
06	Digital Input 2	Preset Freq	Program with A052 [Digital In2 Sel].	A052
07	Digital Input 3	Local	Program with A053 [Digital In3 Sel].	A053
08	Digital Input 4	Jog Forward	Program with A054 [Digital In4 Sel].	A054
09	Opto Common	–	For opto-coupled outputs. Electronically isolated with opto outputs from analog I/O and digital inputs.	
11	+24V DC	–	Referenced to Digital Common. Drive supplied power for digital inputs. Maximum output current is 100mA.	
12	+10V DC	–	Referenced to Analog Common. Drive supplied power for 0-10V external potentiometer. Maximum output current is 15mA.	P038
13	±10V In <sup>(2)</sup>	Not Active	For external 0-10V (unipolar) or ±10V (bipolar) input supply (input impedance = 100k ohm) or potentiometer wiper.	P038, A051-A054, A123, A132
14	Analog Common	–	For 0-10V In or 4-20mA In. Electronically isolated with analog inputs and outputs from digital I/O and opto outputs.	
15	4-20mA In <sup>(2)</sup>	Not Active	For external 4-20mA input supply (input impedance = 250 ohm).	P038, A051-A054, A132
16	Analog Output	OutFreq 0-10	The default analog output is 0-10V. To convert to a current value, change the Analog Output Select DIP Switch to 0-20mA. Program with A065 [Analog Out Sel]. Max analog value can be scaled with A066 [Analog Out High]. Maximum Load: 4-20mA = 525 ohm (10.5V) 0-10V = 1k ohm (10mA)	A065, A066
17	Opto Output 1	MotorRunning	Program with A058 [Opto Out1 Sel]	A058, A059, A064
18	Opto Output 2	At Frequency	Program with A061 [Opto Out2 Sel]	A061, A062, A064
19	RS485 (DSI) Shield	–	Terminal should be connected to safety ground - PE when using the RS485 (DSI) communications port.	

(1) See Footnotes (1) and (6) on page 11.

(2) 0-10V In and 4-20mA In are distinct input channels and may be connected simultaneously. Inputs may be used independently for speed control or jointly when operating in PID mode.

## Encoder Interface

The PowerFlex 40P Encoder Interface can source 5 or 12 volt power and accept 5, 12 or 24 volt single ended or differential inputs.

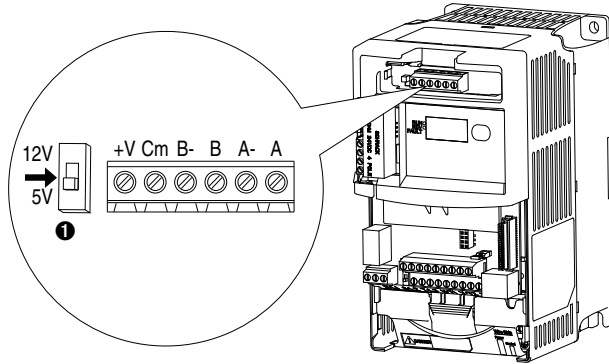

### Terminal Description

No.	Signal	Description
+V	5V-12V Power <sup>(1)</sup>	Internal power source 250 mA (isolated).
Cm	Power Return	
B-	Encoder B (NOT)	Quadrature B input.
B	Encoder B	
A-	Encoder A (NOT)	Single channel, pulse train, or quadrature A input.
A	Encoder A	
❶	Output	DIP switch selects 12 or 5 volt power supplied at terminals "+V" and "Cm" for the encoder.

<sup>(1)</sup> When using 12V Encoder power, 24V I/O power, maximum output current at I/O Terminal 11 is 50 mA.

**Important:** A quadrature encoder provides rotor speed and direction. Therefore, the encoder must be wired such that the forward direction matches the motor forward direction. If the drive is reading encoder speed but the position regulator or other encoder function is not working properly, remove power to the drive and swap the A and A (NOT) encoder channels or swap any two motor leads. Drives using FRN 2.xx and greater will fault when an encoder is incorrectly wired and E216 [Motor Fdbk Type] is set to option 5 "Quad Check".

## Prepare For Drive Start-Up



**ATTENTION:** Power must be applied to the drive to perform the following start-up procedures. Some of the voltages present are at incoming line potential. To avoid electric shock hazard or damage to equipment, only qualified service personnel should perform the following procedure. Thoroughly read and understand the procedure before beginning. If an event does not occur while performing this procedure, **Do Not Proceed. Remove All Power** including user supplied control voltages. User supplied voltages may exist even when main AC power is not applied to the drive. Correct the malfunction before continuing.

### Before Applying Power to the Drive

- 1. Confirm that all inputs are connected to the correct terminals and are secure.
- 2. Verify that AC line power at the disconnect device is within the rated value of the drive.
- 3. Verify that any digital control power is 24 volts.
- 4. Verify that the Sink (SNK)/Source (SRC) Setup DIP Switch is set to match your control wiring scheme. See page 10 for location.

**Important:** The default control scheme is Source (SRC). The Stop terminal is jumpered to allow starting from comms. If the control scheme is changed to Sink (SNK), the jumper must be removed from I/O Terminals 01 and 11 and installed between I/O Terminals 01 and 04.

- 5. Verify that the Stop input is present or the drive will not start.

**Important:** If I/O Terminal 01 is used as a stop input, the jumper between I/O Terminals 01 and 11 must be removed.

### Applying Power to the Drive

- 6. Apply AC power and control voltages to the drive.

### Start, Stop, Direction and Speed Control

Factory default parameter values allow the drive to be controlled from comms. No programming is required to start, stop, change direction and control speed directly from comms.

**Important:** To disable reverse operation, see A095 [Reverse Disable].

If a fault appears on power up, refer to page 19 for an explanation of the fault code. For complete troubleshooting information, refer to the *PowerFlex 40P User Manual*.

## Display/Fault Reset

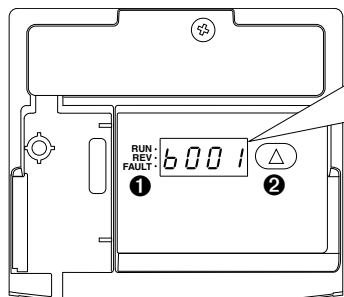

Menu	Description
<b>b</b>	<b>Basic Display Group (View Only)</b> Commonly viewed drive operating conditions.
<b>d</b>	<b>Advanced Display Group (View Only)</b> Consists of advanced drive operating conditions.
<b>F</b>	<b>Fault Designator</b> Consists of list of codes for specific fault conditions. Displayed only when fault is present.

No.	LED	LED State	Description
❶	Run Status	Steady Red	Indicates drive is running.
		Flashing Red	Drive has been commanded to change direction.
	Direction Status	Steady Red	Indicates drive is running in reverse direction.
		Flashing Red	Drive has been commanded to change direction and motor is decelerating to zero.
	Fault Status	Flashing Red	Indicates drive is faulted.

No.	Key	Name	Description
❷		Up Arrow	<b>Scroll:</b> Press and release to scroll through user-selectable Display Group and parameters. <b>Reset:</b> Press and hold for three seconds to clear active fault.

## Drive Programming Tools

For additional drive programming and control, a DSI remote HIM or PC programming tools (DriveExplorer™ or DriveTools™ SP) should be used.

Description	Catalog Number
Converter Module, Serial	22-SCM-232
Converter Module, USB	1203-USB
DriveExplorer Software <sup>(1)</sup>	9306-4EXP02ENE
DriveTools SP Software <sup>(1)</sup>	9303-4DTS01ENE
Remote Panel Mount, LCD Display	22-HIM-C2S
Remote Handheld, LCD Display	22-HIM-A3

<sup>(1)</sup> Requires a Serial or USB Converter Module.

## Set Parameter Display Option

### E201 [LED Display Opt]

Selects which parameters can be viewed by the drive's LED interface.

E201 Option	Parameter Set
0	All Basic Display (Group b) and Advanced Display (Group d) parameters
1	All Basic Display Group (b001-b029) parameters
2	Basic Display Group parameters b001-b007 and b010
3	Basic Display Group parameter b001-b004

<b>Values</b>	Default:	2
	Min/Max:	0/3
	Display:	1

# English-16

## Basic Display Group

	Output Voltage	b004	Contrl In Status	b013	Analog In 4-20mA	b021	
	DC Bus Voltage	b005	Dig In Status	b014	Output Power	b022	
	Drive Status	b006	Comm Status	b015	Output Powr Fctr	b023	
	Fault 1 Code	b007	Control SW Ver	b016	Drive Temp	b024	
	Fault 2 Code	b008	Drive Type	b017	Counter Status	b025	
Output Freq	b001	Fault 3 Code	b009	Elapsed Run Time	b018	Timer Status	b026
Commanded Freq	b002	Process Display	b010	Testpoint Data	b019	Stp Logic Status	b028
Output Current	b003	Control Source	b012	Analog In 0-10V	b020	Torque Current	b029

## Basic Program Group

	Motor NP Volts	P031	Minimum Freq	P034	Accel Time 1	P039
	Motor NP Hertz	P032	Maximum Freq	P035	Decel Time 1	P040
	Motor OL Current	P033	Start Source	P036	Reset To Defaults	P041
			Stop Mode	P037	Voltage Class	P042
			Speed Reference	P038	Motor OL Ret	P043

## Advanced Program Group

	Jog Frequency	A078	Anlg Out Setpt	A109	Stp Logic 0	A140	
	Jog Accel/Decel	A079	Anlg In 0-10V Lo	A110	Stp Logic 1	A141	
	DC Brake Time	A080	Anlg In 0-10V Hi	A111	Stp Logic 2	A142	
	DC Brake Level	A081	Anlg In4-20mA Lo	A112	Stp Logic 3	A143	
	DB Resistor Sel	A082	Anlg In4-20mA Hi	A113	Stp Logic 4	A144	
	S Curve %	A083	Slip Hertz @ FLA	A114	Stp Logic 5	A145	
Digital In1 Sel	A051	Boost Select	A084	Process Time Lo	A115	Stp Logic 6	A146
Digital In2 Sel	A052	Start Boost	A085	Process Time Hi	A116	Stp Logic 7	A147
Digital In3 Sel	A053	Break Voltage	A086	Bus Reg Mode	A117	Stp Logic Time 0	A150
Digital In4 Sel	A054	Break Frequency	A087	Current Limit 2	A118	Stp Logic Time 1	A151
Relay Out Sel	A055	Maximum Voltage	A088	Skip Frequency	A119	Stp Logic Time 2	A152
Relay Out Level	A056	Current Limit 1	A089	Skip Freq Band	A120	Stp Logic Time 3	A153
Opto Out1 Sel	A058	Motor OL Select	A090	Stall Fault Time	A121	Stp Logic Time 4	A154
Opto Out1 Level	A059	PWM Frequency	A091	Analog In Loss	A122	Stp Logic Time 5	A155
Opto Out2 Sel	A061	Auto Rstrl Tries	A092	10V Bipolar Enbl	A123	Stp Logic Time 6	A156
Opto Out2 Level	A062	Auto Rstrl Delay	A093	Var PWM Disable	A124	Stp Logic Time 7	A157
Analog Out Sel	A065	Start At PowerUp	A094	Torque Perf Mode	A125	EM Brk Off Delay	A160
Analog Out High	A066	Reverse Disable	A095	Motor NP FLA	A126	EM Brk On Delay	A161
Accel Time 2	A067	Flying Start En	A096	Autotune	A127	MOP Reset Sel	A162
Decel Time 2	A068	Compensation	A097	IR Voltage Drop	A128	DB Threshold	A163
Internal Freq	A069	SW Current Trip	A098	Flux Current Ref	A129	PID Invert Error	A164
Preset Freq 0	A070	Process Factor	A099	PID Trim Hi	A130		
Preset Freq 1	A071	Fault Clear	A100	PID Trim Lo	A131		
Preset Freq 2	A072	Program Lock	A101	PID Ref Sel	A132		
Preset Freq 3	A073	Testpoint Sel	A102	PID Feedback Sel	A133		
Preset Freq 4	A074	Comm Data Rate	A103	PID Prop Gain	A134		
Preset Freq 5	A075	Comm Node Addr	A104	PID Integ Time	A135		
Preset Freq 6	A076	Comm Loss Action	A105	PID Diff Rate	A136		
Preset Freq 7	A077	Comm Loss Time	A106	PID Setpoint	A137		
		Comm Format	A107	PID Deadband	A138		
		Language	A108	PID Preload	A139		

## Enhanced Program Group

	Comm Write Mode	E207	Motor Fdbk Type	E216	Step Units 0	E230	
	Power Loss Mode	E208	Motor NP Poles	E217	Step Units 1	E232	
	Half Bus Enable	E209	Encoder PPR	E218	Step Units 2	E234	
	Max Traverse	E210	Pulse In Scale	E219	Step Units 3	E236	
	Traverse Inc	E211	Ki Speed Loop	E220	Step Units 4	E238	
LED Display Opt	E201	Traverse Dec	E212	Kp Speed Loop	E221	Step Units 5	E240
Digital Term 3	E202	P Jump	E213	Positioning Mode	E222	Step Units 6	E242
Accel Time 3	E203	Sync Time	E214	Find Home Freq	E223	Step Units 7	E244
Decel Time 3	E204	Speed Ratio	E215	Find Home Dir	E224	Pos Reg Filter	E246
Accel Time 4	E205			Encoder Pos Tol	E225	Pos Reg Gain	E247
Decel Time 4	E206			Counts Per Unit	E226	Enh Control Word	E248
						Cmd Stat Select	E249

## Advanced Display Group

	Drive Status 2	d301	Encoder Speed	d306	Fault 6 Code	d312
	Fibers Status	d302	Units Traveled H	d308	Fault 7 Code	d313
	Slip Hz Meter	d303	Units Traveled L	d309	Fault 8 Code	d314
	Speed Feedback	d304	Fault 4 Code	d310	Fault 9 Code	d315
			Fault 5 Code	d311	Fault 10 Code	d316



## Display Group Parameters

No.	Parameter	Min/Max	Display/Options								
b001	[Output Freq]	0.00/[Maximum Freq]	0.01 Hz								
b002	[Commanded Freq]	0.00/[Maximum Freq]	0.01 Hz								
b003	[Output Current]	0.00/(Drive Amps × 2)	0.01 Amps								
b004	[Output Voltage]	0/Drive Rated Volts	1 VAC								
b005	[DC Bus Voltage]	Based on Drive Rating	1 VDC								
b006	[Drive Status]	0/1 (1 = Condition True)	<table style="width: 100%; border-collapse: collapse;"> <tr> <td style="width: 25%;"><u>Bit 3</u></td> <td style="width: 25%;"><u>Bit 2</u></td> <td style="width: 25%;"><u>Bit 1</u></td> <td style="width: 25%;"><u>Bit 0</u></td> </tr> <tr> <td>Decelerating</td> <td>Accelerating</td> <td>Forward</td> <td>Running</td> </tr> </table>	<u>Bit 3</u>	<u>Bit 2</u>	<u>Bit 1</u>	<u>Bit 0</u>	Decelerating	Accelerating	Forward	Running
<u>Bit 3</u>	<u>Bit 2</u>	<u>Bit 1</u>	<u>Bit 0</u>								
Decelerating	Accelerating	Forward	Running								
b007- b009	[Fault x Code]	F2/F122	F1								
b010	[Process Display]	0.00/9999	0.01 – 1								
b012	[Control Source]	0/112	<table style="width: 100%; border-collapse: collapse;"> <tr> <td style="width: 50%;"><u>Digit 4</u></td> <td style="width: 50%;"><u>Digit 2 &amp; 3 = Speed Command</u></td> </tr> <tr> <td>Reserved</td> <td>01-11</td> </tr> <tr> <td><u>Digit 1 = Start Command</u></td> <td></td> </tr> <tr> <td>1, 2 &amp; 9</td> <td></td> </tr> </table>	<u>Digit 4</u>	<u>Digit 2 &amp; 3 = Speed Command</u>	Reserved	01-11	<u>Digit 1 = Start Command</u>		1, 2 & 9	
<u>Digit 4</u>	<u>Digit 2 &amp; 3 = Speed Command</u>										
Reserved	01-11										
<u>Digit 1 = Start Command</u>											
1, 2 & 9											
b013	[Contrl In Status]	0/1 (1 = Input Present)	<table style="width: 100%; border-collapse: collapse;"> <tr> <td style="width: 25%;"><u>Bit 3</u></td> <td style="width: 25%;"><u>Bit 2</u></td> <td style="width: 25%;"><u>Bit 1</u></td> <td style="width: 25%;"><u>Bit 0</u></td> </tr> <tr> <td>DB Trans On</td> <td>Stop Input</td> <td>Dir/REV In</td> <td>Start/FWD In</td> </tr> </table>	<u>Bit 3</u>	<u>Bit 2</u>	<u>Bit 1</u>	<u>Bit 0</u>	DB Trans On	Stop Input	Dir/REV In	Start/FWD In
<u>Bit 3</u>	<u>Bit 2</u>	<u>Bit 1</u>	<u>Bit 0</u>								
DB Trans On	Stop Input	Dir/REV In	Start/FWD In								
b014	[Dig In Status]	0/1 (1 = Input Present)	<table style="width: 100%; border-collapse: collapse;"> <tr> <td style="width: 25%;"><u>Bit 3</u></td> <td style="width: 25%;"><u>Bit 2</u></td> <td style="width: 25%;"><u>Bit 1</u></td> <td style="width: 25%;"><u>Bit 0</u></td> </tr> <tr> <td>Digital In 4</td> <td>Digital In 3</td> <td>Digital In 2</td> <td>Digital In 1</td> </tr> </table>	<u>Bit 3</u>	<u>Bit 2</u>	<u>Bit 1</u>	<u>Bit 0</u>	Digital In 4	Digital In 3	Digital In 2	Digital In 1
<u>Bit 3</u>	<u>Bit 2</u>	<u>Bit 1</u>	<u>Bit 0</u>								
Digital In 4	Digital In 3	Digital In 2	Digital In 1								
b015	[Comm Status]	0/1 (1 = Condition True)	<table style="width: 100%; border-collapse: collapse;"> <tr> <td style="width: 25%;"><u>Bit 3</u></td> <td style="width: 25%;"><u>Bit 2</u></td> <td style="width: 25%;"><u>Bit 1</u></td> <td style="width: 25%;"><u>Bit 0</u></td> </tr> <tr> <td>Comm Error</td> <td>DSI Option</td> <td>Transmitting</td> <td>Receiving</td> </tr> </table>	<u>Bit 3</u>	<u>Bit 2</u>	<u>Bit 1</u>	<u>Bit 0</u>	Comm Error	DSI Option	Transmitting	Receiving
<u>Bit 3</u>	<u>Bit 2</u>	<u>Bit 1</u>	<u>Bit 0</u>								
Comm Error	DSI Option	Transmitting	Receiving								
b016	[Control SW Ver]	1.00/99.99	0.01								
b017	[Drive Type]	1001/9999	1								
b018	[Elapsed Run Time]	0/9999 Hrs	1 = 10 Hrs								
b019	[Testpoint Data]	0/FFFF	1 Hex								
b020	[Analog In 0-10V]	0.0/100.0%	0.1%								
b021	[Analog In 4-20mA]	0.0/100.0%	0.1%								
b022	[Output Power]	0.00/(Drive Power × 2)	0.01 kW								
b023	[Output Powr Fctr]	0.0/180.0 deg	0.1 deg								
b024	[Drive Temp]	0/120 degC	1 degC								
b025	[Counter Status]	0/9999	1								
b026	[Timer Status]	0.0/9999 Secs	0.1 Secs								
b028	[Stp Logic Status]	0/8	1								
b029	[Torque Current]	0.00/(Drive Amps × 2)	0.01 Amps								

## Smart Start-Up with Program Group Parameters

The PowerFlex 40P is designed so that start up is simple and efficient. The Program Group contains the most commonly used parameters.

= Stop drive before changing this parameter.

No.	Parameter	Min/Max	Display/Options	Default
P031	[Motor NP Volts] <input type="radio"/> Set to the motor nameplate rated volts.	20/Drive Rated Volts	1 VAC	Based on Drive Rating
P032	[Motor NP Hertz] <input type="radio"/> Set to the motor nameplate rated frequency.	15/500 Hz	1 Hz	60 Hz
P033	[Motor OL Current] Set to the maximum allowable motor current.	0.0/(Drive Rated Amps×2)	0.1 Amps	Based on Drive Rating
P034	[Minimum Freq] Sets the lowest frequency the drive will output continuously.	0.00/500.0 Hz	0.01 Hz	0.00 Hz
P035	[Maximum Freq] <input type="radio"/> Sets the highest frequency the drive will output.	0.00/500.0 Hz	0.01 Hz	60.00 Hz

## English-18

= Stop drive before changing this parameter.

No.	Parameter	Min/Max	Display/Options	Default
P036	[Start Source] <input type="radio"/> Sets the control scheme used to start the drive.	1/6	1 = "3-Wire" 2 = "2-Wire" 3 = "2-W Lvl Sens" 4 = "2-W Hi Speed" 5 = "Comm Port" 6 = "Momt FWD/REV"	5
P037	[Stop Mode] Active stop mode for all stop sources [e.g. run forward (I/O Terminal 02), run reverse (I/O Terminal 03), RS485 port] except as noted. <b>Important:</b> I/O Terminal 01 is always a coast to stop input except when P036 [Start Source] is set for "3-Wire" control. When in three wire control, I/O Terminal 01 is controlled by P037 [Stop Mode].	0/9	0 = "Ramp, CF" <sup>(1)</sup> 1 = "Coast, CF" <sup>(1)</sup> 2 = "DC Brake, CF" <sup>(1)</sup> 3 = "DCBrkAuto,CF" <sup>(1)</sup> 4 = "Ramp" 5 = "Coast" 6 = "DC Brake" 7 = "DC BrakeAuto" 8 = "Ramp+EM B,CF" 9 = "Ramp+EM Brk" <sup>(1)</sup> Stop input also clears active fault.	0
P038	[Speed Reference] Sets the source of the speed reference to the drive. <b>Important:</b> When A051 or A052 [Digital Inx Sel] is set to option 2, 4, 5, 6, 13 or 14 and the digital input is active, A051, A052, A053 or A054 will override the speed reference commanded by this parameter. Refer to Chapter 1 of the PowerFlex 40P <i>User Manual</i> for details.	1/9	1 = "InternalFreq" 2 = "0-10V Input" 3 = "4-20mA Input" 4 = "Preset Freq" 5 = "Comm Port" 6 = "Stp Logic" 7 = "Anlg In Mult" 8 = "Encoder" 9 = "Positioning"	5
P039	[Accel Time 1] Sets the rate of accel for all speed increases.	0.0/600.0 Secs	0.1 Secs	10.0 Secs
P040	[Decel Time 1] Sets the rate of decel for all speed decreases.	0.0/600.0 Secs	0.1 Secs	10.0 Secs
P041	[Reset To Defaults] <input type="radio"/> Resets all parameter values to factory defaults.	0/1	0 = "Ready/Idle" 1 = "Factory Rset"	0
P042	[Voltage Class] <input type="radio"/> Sets the voltage class of 600V drives.	2/3	2 = "Low Voltage" (480V) 3 = "High Voltage" (600V)	3
P043	[Motor OL Ret] Enables/disables the Motor Overload Retention function.	0/1	1 = "Enabled"	0 = "Disabled"

## Advanced Program Group Parameters

= Stop drive before changing this parameter.

No.	Parameter	Min/Max	Display/Options	Default
A125	[Torque Perf Mode] <input type="radio"/> Enables/disables sensorless vector control operation.	0/1	0 = "V/Hz" 1 = "Sensrls Vect"	1
A126	[Motor NP FLA] Set to the motor nameplate rated full load amps.	0.1/(Drive Rated Amps x 2)	0.1 Amps	Drive Rated Amps
A127	[Autotune] <input type="radio"/> Provides an automatic method for setting A128 [IR Voltage Drop] and A129 [Flux Current Ref], which affect sensorless vector performance. Parameter A126 [Motor NP FLA] must be set to the motor nameplate full load amps before running the Autotune procedure.	0/2	0 = "Ready/Idle" 1 = "Static Tune" 2 = "Rotate Tune"	0

## Enhanced Program Group Parameters

 = Stop drive before changing this parameter.

No.	Parameter	Min/Max	Display/Options	Default
E216	[Motor Fdbk Type]  Selects the encoder type.	0/5	0 = "None" 1 = "Pulse Train" 2 = "Single Chain" 3 = "Single Check" 4 = "Quadrature" 5 = "Quad Check"	0
E217	[Motor NP Poles] Defines the number of poles in the motor.	2/40	1	4
E218	[Encoder PPR] Specifies the encoder pulses per revolution when an encoder is used. For additional information refer to Appendix F of the PowerFlex 40P <i>User Manual</i> .	1/20000	1	1024

## Program Group Parameters

Refer to the PowerFlex 40P *User Manual* supplied with the drive for complete listing of parameters.

## Advanced Display Group Parameters

No.	Parameter	Min/Max	Display/Options
d301	[Drive Status 2]	0/1	1
d302	[Fibers Status]	0/1	1
d303	[Slip Hz Meter]	0.0/25.0 Hz	0.1 Hz
d304	[Speed Feedback]	0/64000 RPM	1 RPM
d305	[Speed Feedback F]	0.0/0.9	0.1
d306	[Encoder Speed]	0/64000	1
d307	[Encoder Speed F]	0.0/0.9	0.1
d308	[Units Traveled H]	0/64000	1
d309	[Units Traveled L]	0.00/0.99	0.01
d310	[Fault 4 Code]	0/122	1
d311	[Fault 5 Code]	0/122	1
d312	[Fault 6 Code]	0/122	1
d313	[Fault 7 Code]	0/122	1
d314	[Fault 8 Code]	0/122	1
d315	[Fault 9 Code]	0/122	1
d316	[Fault 10Code]	0/122	4

## Fault Codes

To clear a fault, press the Stop key, cycle power or set A100 [Fault Clear] to 1 or 2.

No.	Fault	Description
F2	Auxiliary Input <sup>(1)</sup>	Check remote wiring. Verify communications programming for intentional fault.
F3	Power Loss	Monitor the incoming AC line for low voltage or line power interruption. Check input fuses.
F4	UnderVoltage <sup>(1)</sup>	Monitor the incoming AC line for low voltage or line power interruption.
F5	OverVoltage <sup>(1)</sup>	Monitor the AC line for high line voltage or transient conditions. Bus overvoltage can also be caused by motor regeneration. Extend the decel time or install dynamic brake option.

## English-20

No.	Fault	Description
F6	Motor Stalled <sup>(1)</sup>	Increase [Accel Time x] or reduce load so drive output current does not exceed the current set by parameter A089 [Current Limit].
F7	Motor Overload <sup>(1)</sup>	An excessive motor load exists. Reduce load so drive output current does not exceed the current set by parameter P033 [Motor OL Current]. Verify A084 [Boost Select] setting.
F8	Heatsink OvrTmp <sup>(1)</sup>	Check for blocked or dirty heat sink fins. Verify that ambient temperature has not exceeded 40°C (104°F) for IP 30/NEMA 1/UL Type 1 installations or 50°C (122°F) for Open type installations. Check fan.
F12	HW OverCurrent	Check programming. Check for excess load, improper DC boost setting, DC brake volts set too high or other causes of excess current.
F13	Ground Fault	Check the motor and external wiring to the drive output terminals for a grounded condition.
F29	Analog Input Loss <sup>(1)</sup>	An analog input is configured to fault on signal loss. A signal loss has occurred. Check parameters. Check for broken/loose connections at inputs.
F33	Auto Rstrt Tries	Correct the cause of the fault and manually clear.
F38	Phase U to Gnd	Check the wiring between the drive and motor.
F39	Phase V to Gnd	Check motor for grounded phase.
F40	Phase W to Gnd	Replace drive if fault cannot be cleared.
F41	Phase UV Short	Check the motor and drive output terminal wiring for a shorted condition.
F42	Phase UW Short	Replace drive if fault cannot be cleared.
F43	Phase VW Short	
F48	Params Defaulted	The drive was commanded to write default values to EEPROM. Clear the fault or cycle power to the drive. Program the drive parameters as needed.
F63	SW OverCurrent <sup>(1)</sup>	Check load requirements and A098 [SW Current Trip] setting.
F64	Drive Overload	Reduce load or extend Accel Time.
F70	Power Unit	Cycle power. Replace drive if fault cannot be cleared.
F71	Net Loss	The communication network has faulted. Cycle power. Check communications cabling. Check network adapter setting. Check external network status.
F80	SVC Autotune	The autotune function was either cancelled by the user or failed. Restart procedure.
F81	Comm Loss	If adapter was not intentionally disconnected, check wiring to the port. Replace wiring, port expander, adapters or complete drive as required. Check connection. An adapter was intentionally disconnected. Turn off using A105 [Comm Loss Action]. Connecting I/O Terminal 04 to ground may improve noise immunity.
F91	Encoder Loss	Requires differential encoder. One of the 2 encoder channel signals is missing. Check Wiring. If P038 [Speed Reference] = 9 "Positioning" and E216 [Motor Fdbk Type] = 5 "Quad Check" swap the Encoder channel inputs (see page 13) or swap any two motor leads. Replace encoder.
F100	Parameter Checksum	Restore factory defaults.
F111	Enable Hardware	DriveGuard Safe-Off Option (Series B) board is installed and the ENBL enable jumper has not been removed. Remove the ENBL enable jumper. Cycle power. DriveGuard Safe-Off Option (Series B) board has failed. Remove power to the drive. Replace DriveGuard Safe-Off Option (Series B) board. Hardware Enable circuitry has failed. Replace drive.
F122	I/O Board Fail	Cycle power. Replace drive if fault cannot be cleared.

<sup>(1)</sup> Auto-Reset/Run type fault. Configure with parameters A092 and A093.

## Drive Dimensions

PowerFlex 40P Frames – Ratings are in kW and (HP)

Frame	240V AC – 3-Phase		480V AC – 3-Phase		600V AC – 3-Phase	
B	0.4 (0.5)	2.2 (3.0)	0.4 (0.5)	2.2 (3.0)	0.75 (1.0)	4.0 (5.0)
	0.75 (1.0)	3.7 (5.0)	0.75 (1.0)	4.0 (5.0)	1.5 (2.0)	2.2 (3.0)
	1.5 (2.0)		1.5 (2.0)			
C	5.5 (7.5)		5.5 (7.5)	11.0 (15.0)	5.5 (7.5)	11.0 (15.0)
	7.5 (10.0)		7.5 (10.0)		7.5 (10.0)	

### PowerFlex 40P AC Drive

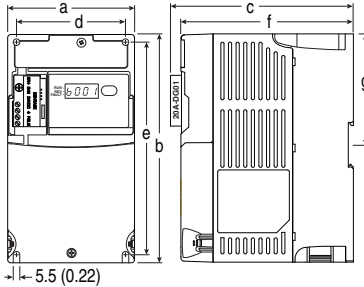

Dimensions are in millimeters and (inches).  
Weights are in kilograms and (pounds).

Frame	a	b	c	d	e	f	g	Ship Weight
B	100 (3.94)	180 (7.09)	148 (5.83)	87 (3.43)	168 (6.61)	136 (5.35)	87.4 (3.44)	2.2 (4.9)
C	130 (5.1)	260 (10.2)	192 (7.56)	116 (4.57)	246 (9.7)	180 (7.1)	–	4.3 (9.5)

### Communication, RFI Filter, IP 30/NEMA 1/UL Type 1 Option Kits

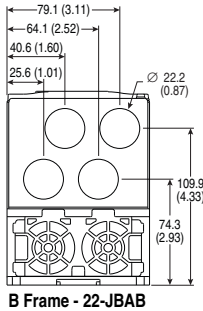
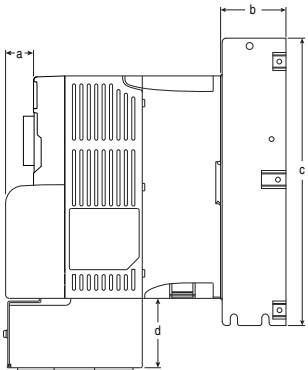

B Frame - 22-JBAB

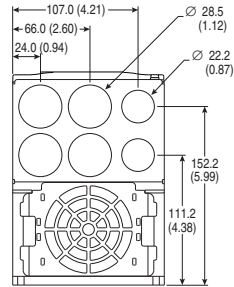

C Frame - 22-JBAC

Dimension	Option	B Frame Drive	C Frame Drive
a	Comm Cover	25 (0.98)	25 (0.98)
b	EMC Line Filter	50 (1.97)	60 (2.36)
c	EMC Line Filter	229 (9.02)	309 (12.17)
d	IP30/NEMA 1/UL Type 1	33 (1.30)	60 (2.36)
	IP30/NEMA 1/UL Type 1 for Comm Cover	64 (2.52)	60 (2.36)

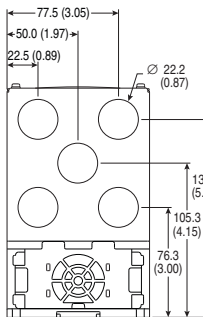

B Frame - 22-JBCB  
(used with Comm Cover)

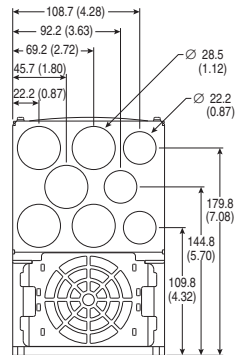

C Frame - 22-JBCC  
(used with Comm Cover)

**Notes:**