

PowerFlex 400 AC Drive Packages for Fan and Pump

Catalog Number 23C

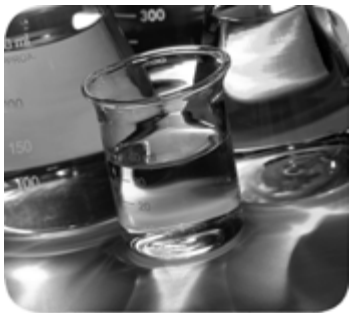

Important User Information

Read this document and the documents listed in the additional resources section about installation, configuration, and operation of this equipment before you install, configure, operate, or maintain this product. Users are required to familiarize themselves with installation and wiring instructions in addition to requirements of all applicable codes, laws, and standards.

Activities including installation, adjustments, putting into service, use, assembly, disassembly, and maintenance are required to be carried out by suitably trained personnel in accordance with applicable code of practice.

If this equipment is used in a manner not specified by the manufacturer, the protection provided by the equipment may be impaired.

In no event will Rockwell Automation, Inc. be responsible or liable for indirect or consequential damages resulting from the use or application of this equipment.

The examples and diagrams in this manual are included solely for illustrative purposes. Because of the many variables and requirements associated with any particular installation, Rockwell Automation, Inc. cannot assume responsibility or liability for actual use based on the examples and diagrams.

No patent liability is assumed by Rockwell Automation, Inc. with respect to use of information, circuits, equipment, or software described in this manual.

Reproduction of the contents of this manual, in whole or in part, without written permission of Rockwell Automation, Inc., is prohibited.

Throughout this manual, when necessary, we use notes to make you aware of safety considerations.



WARNING: Identifies information about practices or circumstances that can cause an explosion in a hazardous environment, which may lead to personal injury or death, property damage, or economic loss.



ATTENTION: Identifies information about practices or circumstances that can lead to personal injury or death, property damage, or economic loss. Attentions help you identify a hazard, avoid a hazard, and recognize the consequence.

IMPORTANT Identifies information that is critical for successful application and understanding of the product.

Labels may also be on or inside the equipment to provide specific precautions.



SHOCK HAZARD: Labels may be on or inside the equipment, for example, a drive or motor, to alert people that dangerous voltage may be present.



BURN HAZARD: Labels may be on or inside the equipment, for example, a drive or motor, to alert people that surfaces may reach dangerous temperatures.



ARC FLASH HAZARD: Labels may be on or inside the equipment, for example, a motor control center, to alert people to potential Arc Flash. Arc Flash will cause severe injury or death. Wear proper Personal Protective Equipment (PPE). Follow ALL Regulatory requirements for safe work practices and for Personal Protective Equipment (PPE).

	Summary of Changes	7	
	Preface	9	
	Manual Conventions	10	
	General Precautions	10	
	Catalog Number Explanation	11	
	Additional Resources	12	
	Chapter 1		
Main Input Disconnect Package (Style A/M)	Style Explanation	13	
	Hardware Overview	13	
	Main Disconnect Switch (DS1)	13	
	Main Circuit Breakers (CB1)	13	
	Main Fuses (FU1-FU3)	14	
	Electrical Installation	15	
	Input Power Wiring	15	
	Output Power Wiring	16	
	Control and Signal Wiring	17	
	Parameter Defaults (Style A/M)	18	
	Drawing Index	19	
	208V AC Input – Main Input Disconnect Drive Packages (Style A/M)	19	
	460V AC – Main Input Disconnect Drive Packages (Style A/M)	20	
	Schematic Drawings	22	
	Interconnect Drawings	29	
	Layout Drawings	34	
	Outline Drawings	70	
		Chapter 2	
	3 Contactor Full Feature Bypass with Disconnect Package (Style B/N)	Style Explanation	87
		Hardware Overview	87
Main Disconnect Switch (DS1)		87	
Main Circuit Breakers (CB1)		87	
Main Fuses (FU1-FU3)		88	
Contactors (DIC, DOC, BC)		89	
Motor Overload Relay (OL)		89	
Control Transformer (T1)		91	
Bypass Control Interface (CPI)		91	
Electrical Installation		92	
Input Power Wiring		92	
Output Power Wiring		93	
Control and Signal Wiring		94	

Customer Connections 95

 Interlock 95

 Freeze/Fire Stat 95

 Autostart 95

 Bypass 95

 Purge 96

 Bypass Running 96

Operating Modes 96

Parameter Defaults (Style B/N) 97

Drawing Index 98

 208V AC – 3 Contactor Full Feature Bypass with
 Disconnect Package (Style B/N) 98

 460V AC – 3 Contactor Full Feature Bypass with
 Disconnect Package (Style B/N) 99

Schematic Drawings 101

Interconnect Drawings 117

Layout Drawings 122

Outline Drawings 159

Chapter 3

Mechanical Installation

Mounting Considerations 177

 Environment 177

 Maximum Surrounding Air Temperature 177

 Minimum Mounting Clearances 177

Lifting and Mounting the Drive 180

Watts Loss 181

Weights 182

Chapter 4

Electrical Installation

Power Wire Size Requirements 185

Power Terminal Block Specification 185

Control and Signal Wiring 186

Installing Input Power Wiring 186

Installing Output Power Wiring 187

Installing an Optional Transformer or Reactor 187

 Installing Fuses for Branch Circuit Protection 188

 Installing the Required External/Separate Input Disconnect 189

 Installing Input/Output Power Wiring 189

Supplemental Information	Appendix A	
	Specifications	191
Replacement Parts	Appendix B	
	Common Parts	193
	Disconnect Parts	194
	Bypass Parts	197
	Enclosure Parts	199
History of Changes	Appendix C	
	23C-IN001B-EN-P, June 2013	205
	23C-IN001C-EN-P, November 2015	205

Notes:

This manual contains new and updated information.

New and Updated Information

This table contains the changes made to this revision.

Topic	Page
Added ATTENTION statement clarifying branch circuit protection.	10
Updated Catalog Number Explanation to comply to current standards.	11
Added statement clarifying branch circuit protection.	13
Replaced Figure 4 with updated branch circuit protection drawing.	25
Replaced Figure 72 with updated branch circuit protection drawing.	105
Update part numbers for the Style A/B Fused Disconnect Packages, Operator Handle for NEMA/UL Type 1, 12, 3R, 4.	194
Added part numbers for Style M/N Circuit Breaker Packages Operator Handle (NEMA/UL Type 1/12) for Enclosure Options A and H and Operator Handle (NEMA/UL Type 3R/4) for Enclosure Options X and E.	196

Notes:

The purpose of this manual is to provide basic information that is needed to install, start-up, and troubleshoot PowerFlex[®] 400 Adjustable Frequency AC Drive Packages for Fan and Pump Applications.

User documentation for the PowerFlex 400 Drive Packages for Fan and Pump Applications includes these Installation Instructions and the PowerFlex 400 User Manual, publication [22C-UM001](#). Both manuals are required to properly install and operate the PowerFlex 400 Adjustable Frequency AC Drive Packages for Fan and Pump Applications.

Topic	Page
Manual Conventions	10
General Precautions	10
Catalog Number Explanation	11
Additional Resources	12

This manual is intended for qualified personnel. You must be able to program and operate Adjustable Frequency AC Drive devices. In addition, you must have an understanding of the parameter settings and functions.

The PowerFlex 400 Adjustable Frequency AC Drive Packages for Fan and Pump Applications Installation Instructions is designed to provide only basic installation and operation information. For this reason, the following topics have not been included:

- Specifications
- Troubleshooting
- Startup
- Programming and Parameters

Refer to the PowerFlex 400 User Manual, publication [22C-UM001](#) for detailed drive information.

Manual Conventions

- To help differentiate parameter names and LCD display text from other text, the following conventions will be used:
 - Parameter Names appear in [brackets].
For example: [DC Bus Voltage].
 - Display Text appear in “quotes.” For example: “Enabled.”
- The following words are used throughout the manual to describe an action:

Word	Meaning
Can	Possible, able to do something
Cannot	Not possible, not able to do something
May	Permitted, allowed
Must	Unavoidable, you must do this
Shall	Required and necessary
Should	Recommended
Should Not	Not recommended

General Precautions



ATTENTION: This drive contains ESD (Electrostatic Discharge) sensitive parts and assemblies. Static control precautions are required when installing, testing, servicing, or repairing this assembly. Component damage may result if ESD control procedures are not followed. If you are not familiar with static control procedures, reference Allen-Bradley® publication 8000-4.5.2, “Guarding Against Electrostatic Damage” or any other applicable ESD protection handbook.



ATTENTION: An incorrectly applied or installed drive can result in component damage or a reduction in product life. Wiring or application errors, such as, undersizing the motor, incorrect or inadequate AC supply, or excessive ambient temperatures may result in malfunction of the system.



ATTENTION: Only qualified personnel familiar with adjustable frequency AC drives and associated machinery should plan or implement the installation, start-up and subsequent maintenance of the system. Failure to comply may result in personal injury and/or equipment damage.



ATTENTION: To avoid an electric shock hazard, verify that the voltage on the bus capacitors has discharged before performing any work on the drive. Measure the voltage at the drive (Refer to the PowerFlex 400 User Manual, publication [22C-UM001](#) for test point locations). The voltage must be zero.



ATTENTION: When provided with a circuit breaker, the circuit breaker serves as a disconnect only. Suitable branch circuit protection, such as fuses, need to be provided upstream of the circuit breaker.

Catalog Number Explanation

The PowerFlex 400 Adjustable Frequency AC Drive Packages for Fan and Pump Applications catalog numbering scheme is shown.

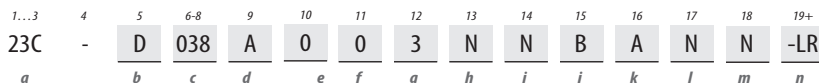

a

Drive	
Code	Type
23C	PowerFlex 400

b

Voltage Rating		
Code	Voltage	Phase
X	208V AC	3
D	480V AC	3

c1

Rating			
208V, 60 Hz Input			
Code	Amps ⁽¹⁾	kW (Hp)	Frame
012	12	2.2 (3.0)	C
017	16.8	3.7 (5.0)	C
024	24	5.5 (7.5)	C
033	30.8	7.5 (10)	C
049	46.2	11 (15)	D
065	64	15 (20)	D
075	75	18.5 (25)	D
090	88	22 (30)	D
120	114	30 (40)	E
145	143	37 (50)	E

(1) Configured drive amp ratings may differ from standalone drive ratings. Configured drives sized per NEC motor amps.

c2

Rating			
460V, 60 Hz Input			
Code	Amps ⁽¹⁾	kW (Hp)	Frame
6P0	4.8	2.2 (3.0)	C
010	7.6	4.0 (5.0)	C
012	11	5.5 (7.5)	C
017	14	7.5 (10)	C
022	21	11 (15)	C
030	27	15 (20)	C
038	34	18.5 (25)	D
045	40	22 (30)	D
060	52	30 (40)	D
072	65	37 (50)	E
088	77	45 (60)	E
105	96	55 (75)	E
142	124	75 (100)	E
170	156	90 (125)	F
208	180	110 (150)	F
260	240	132 (200)	G
310	302	160 (250)	G
370	361	200 (300)	H
460	414	250 (350)	H

(1) Configured amp ratings may differ from standalone drive ratings. Configured drives sized per NEC motor amps.

d

Enclosure	
Code	Enclosure
A	NEMA/UL Type 1
H	NEMA/UL Type 12 with Fan and Filter
X	NEMA/UL Type 3R ⁽¹⁾
E	NEMA/UL Type 4 ⁽¹⁾

(1) Designed for maximum ambient temperature of 40° C with no direct sunlight exposure.

e

HIM	
Code	Interface Module
1	Fixed Keypad

f

Emission Class	
Code	Rating
0	Not Filtered

g

Version	
Code	Version
3	RS-485
B	BACnet Adapter
C	ControlNet [®] Adapter
D	DeviceNet [®] Adapter
E	EtherNet/IP [™] Adapter
L	LonWorks Adapter
P	PROFIBUS DP Adapter

h

Code	Rating
N	Reserved

i

Code	Rating
N	Reserved

j

Package	
Code	Description
A	Main Input Disconnect ⁽¹⁾
B	3 Contactor Full Feature Bypass with Disconnect ⁽²⁾
M	Main Input Circuit Breaker ⁽³⁾
N	3 Contactor Full Feature Bypass with Circuit Breaker

- (1) Not available with all ratings at 460V. Consult product selection tables for details.
- (2) Not available with all ratings at 460V. Consult product selection tables for details.
- (3) Available with all ratings in NEMA/UL Type 12, 3R, or 4 enclosures (Position d = H, X, or E) and 160...250 kW (250...350 Hp) ratings in NEMA/UL Type 1 enclosures (Position d = A).

k

Control	
Code	Description
A	Single Motor

l

Code	Rating
N	Reserved

m

Code	Rating
N	Reserved

n

Options	
Code	Description
-LR	3% Input Line Reactor ⁽¹⁾
-E5	Space Heater - Local Power ⁽²⁾

- (1) 3% Input Line Reactor not available for all package styles. Consult product selection tables for additional detail.
- (2) Available with NEMA/UL Type 3R and 4 enclosures only.

Additional Resources

These documents contain additional information concerning related products from Rockwell Automation.

Resource	Description
Wiring and Grounding Guidelines for Pulse Width Modulated (PWM) AC Drives, publication DRIVES-IN001	Provides the basic information that is needed to properly wire and ground Pulse Width Modulated (PWM) AC drives.
Preventive Maintenance of Industrial Control and Drive System Equipment, publication DRIVES-TD001	Contains a checklist that can be used as a guide to perform preventive maintenance on variable frequency AC drives.
PowerFlex 400 User Manual, publication 22C-UM001	Provides the basic information that is needed to install, start-up, and troubleshoot the PowerFlex® 400 Adjustable Frequency AC Drive.
Industrial Automation Wiring and Grounding Guidelines, publication 1770-4.1	Provides general guidelines for installing a Rockwell Automation® industrial system.
Product Certifications website, http://www.ab.com	Provides declarations of conformity, certificates, and other certification details.

You can view or download publications at <http://www.rockwellautomation.com/literature/>. To order paper copies of technical documentation, contact your local Allen-Bradley distributor or Rockwell Automation sales representative.

Main Input Disconnect Package (Style A/M)

This chapter describes the features and operation for the Main Input Disconnect Package (Style A/M).

Topic	Page
Hardware Overview	13
Electrical Installation	15
Parameter Defaults (Style A/M)	18
Drawing Index	19
Schematic Drawings	22
Interconnect Drawings	29
Layout Drawings	34
Outline Drawings	70

Style Explanation

- Style A = Fused Disconnect
- Style M = Circuit Breaker

Hardware Overview

The Main Input Disconnect Package (Style A/M) combines an Adjustable Frequency AC Drive with a means for disconnecting input power within a package. Input power is connected to the PowerFlex® drive through a door interlocked fuse disconnect switch or circuit breaker.

Main Disconnect Switch (DS1)

An Allen-Bradley® Bulletin 194R™ Fused Disconnect Switch with lockable rotary-mounted operator handle is provided. The disconnect switch is designed to meet disconnect switch requirements for branch circuit protection. The door-mounted handle accepts up to three padlocks.

Main Circuit Breakers (CB1)

A circuit breaker with lockable rotary-mounted operator handle is provided. It is important to note that the circuit breaker serves as a disconnect only. Suitable branch circuit protection, such as fuses, need to be provided upstream of the circuit breaker. The door-mounted handle accepts up to three padlocks.

Main Fuses (FU1-FU3)



ATTENTION: Most codes require that upstream branch circuit protection be provided to help protect input power wiring. Install the fuses recommended in [Table 1](#). Do not exceed the fuse ratings. Failure to observe this precaution could result in damage to, or destruction of, the equipment.

Input line branch circuit protection fuses must be used to help protect the input power lines. If input fuses are not provided with your drive, see the recommended fuse values shown in [Table 1](#). The input fuse ratings that are listed in [Table 1](#) are applicable for one drive per branch circuit. No other load may be applied to that fused circuit.

The recommended fuse type for all PowerFlex 400 Drive Packages for Fan and Pump Applications is UL Class J.

Table 1 - Fuse Recommendations

Drive Rating			Fuse Rating
Input Voltage	kW	Hp	Amps
208V AC – 3 Phase	2.2	3.0	20
	3.7	5.0	20
	5.5	7.5	35
	7.5	10	40
	11	15	80
	15	20	100
	18.5	25	125
	22	30	150
	30	40	200
	37	50	250
460V AC – 3 Phase	2.2	3.0	10
	4.0	5.0	15
	5.5	7.5	20
	7.5	10	20
	11	15	35
	15	20	35
	18.5	25	60
	22	30	70
	30	40	80
	37	50	100
	45	60	150
	55	75	175
	75	100	200
	90	125	250
	110	150	350
	132	200	400
160	250	500	
200	300	600	
250	350	700	

Electrical Installation

Input Power Wiring

Use 75 °C rated copper conductors only for customer power wiring.

See the PowerFlex 400 User Manual, publication [22C-UM001](#) for additional detailed information about input power wiring recommendations and selection.



ATTENTION: Protect the contents of the options cabinet from metal chips and other debris while drilling the conduit openings. Failure to observe this precaution could result in damage to, or destruction of, the equipment.



ATTENTION: Do not route signal and control wiring with power wiring in the same conduit. This can cause interference with drive operation. Failure to observe this precaution could result in damage to, or destruction of, the equipment.

To connect AC input power to the drive package:

- ❑ 1. Select the proper wire size according to NEC and all applicable local codes and standards. You must punch openings in the Option Cabinet of the desired conduit size, following NEC, and all applicable local codes and standards. Power terminal block specifications are listed in [Table 2](#).
- ❑ 2. Connect the three-phase AC input power leads (three-wire VAC) to the appropriate terminals. Connect the AC input power leads to terminals L1, L2, L3 on the fused disconnect switch.
- ❑ 3. Tighten the AC input terminal power terminals to the proper torque according to drive type as shown in [Table 2](#).

Table 2 - AC Input Power Terminal Block Specifications

Volts AC	kW	Hp	Maximum Wire Size ⁽¹⁾	Minimum Wire Size	Recommended Torque
208V	2.2...3.7	3.0...5.0	8.4 mm ² (8 AWG)	2.5 mm ² (14 AWG)	4.0 N•m (35 lb•in)
	5.5...7.5	7.5...10	16.0 mm ² (4 AWG)	2.5 mm ² (14 AWG)	4.0 N•m (35 lb•in)
	11...15	15...20	33.6 mm ² (2 AWG)	2.5 mm ² (14 AWG)	17.5 N•m (155 lb•in)
	18.5...30	25...40	250 MCM	10.0 mm ² (6 AWG)	31.1 N•m (275 lb•in)
	37	50	350 MCM	35.0 mm ² (1/0 AWG)	31.1 N•m (275 lb•in)
460V	2.2...7.5	3.0...10	8.4 mm ² (8 AWG)	2.5 mm ² (14 AWG)	4.0 N•m (35 lb•in)
	11...18.5	15...25	16.0 mm ² (4 AWG)	2.5 mm ² (14 AWG)	4.0 N•m (35 lb•in)
	22...37	30...50	33.6 mm ² (2 AWG)	2.5 mm ² (14 AWG)	17.5 N•m (155 lb•in)
	45...75	60...100	250 MCM	10.0 mm ² (6 AWG)	31.1 N•m (275 lb•in)
	90...110	125...150	(2) 350 MCM	(2) 10.0 mm ² (6 AWG)	31.1 N•m (275 lb•in)
	132	200	(2) 350 MCM	(2) 35.0 mm ² (1/0 AWG)	31.1 N•m (275 lb•in)
	160...200	250...300	(2) 350 MCM	(2) 70.0 mm ² (3/0 AWG)	31.1 N•m (275 lb•in)
	250	350	(2) 400 MCM	(2) 70.0 mm ² (3/0 AWG)	31.1 N•m (275 lb•in)

(1) Maximum/minimum sizes that the terminal block will accept - these are not recommendations. If national or local codes require sizes outside the range, lugs may be used.

Output Power Wiring

See the PowerFlex 400 User Manual, publication [22C-UM001](#) for additional detailed information about output power wiring recommendations and selection.



ATTENTION: Unused wires in conduit must be grounded at both ends to avoid a possible shock hazard that is caused by induced voltages. Also, if a drive sharing a conduit is being serviced or installed, all drives using this conduit should be disabled to eliminate the possible shock hazard from cross-coupled motor leads. Failure to observe these precautions could result in bodily injury.



ATTENTION: Do not route signal and control wiring with power wiring in the same conduit. This can cause interference with drive operation. Failure to observe this precaution could result in damage to, or destruction of, the equipment.

To connect AC output power wiring from the drive to the motor:

- ❑ 1. Wire the three-phase AC output power motor leads by routing them according to the drive option type. You must punch openings in the option cabinet of the desired conduit size, following NEC, and all applicable local codes and standards. Power terminal block specifications are listed in [Table 3](#).

Do not route more than three sets of motor leads through a conduit. This will minimize cross-talk that could reduce the effectiveness of noise reduction methods. If more than three drive/motor connections per conduit are required, shielded cable must be used. If possible, each conduit should contain only one set of motor leads.

- ❑ 2. Connect the three-phase AC output power motor leads to terminals U, V, W (T1, T2, T3) on the power terminal block on the drive.
- ❑ 3. Tighten the three-phase AC output power terminals to the proper torque according to drive type as shown in [Table 3](#).

Table 3 - AC Output Power Terminal Block Specifications

Volts AC	kW	Hp	Maximum Wire Size ⁽¹⁾	Minimum Wire Size	Recommended Torque
208V	2.2...7.5	3.0...10	8.4 mm ² (8 AWG)	1.3 mm ² (16 AWG)	3.7 N•m (33 lb•in)
	11...22	15...30	33.6 mm ² (2 AWG)	8.4 mm ² (8 AWG)	5.1 N•m (45 lb•in)
	30...37	40...50	33.6 mm ² (2 AWG)	2.5 mm ² (14 AWG)	17.5 N•m (155 lb•in)
460V	2.2...15	3.0...20	8.4 mm ² (8 AWG)	1.3 mm ² (16 AWG)	3.7 N•m (33 lb•in)
	18.5...30	25...40	33.6 mm ² (2 AWG)	8.4 mm ² (8 AWG)	5.1 N•m (45 lb•in)
	37...45	50...60	33.6 mm ² (2 AWG)	3.5 mm ² (12 AWG)	5.6 N•m (49.5 lb•in)
	55...75	75...100	107.2 mm ² (4/0 AWG)	53.5 mm ² (1/0 AWG)	19.5 N•m (173 lb•in)
	90...110	125...150	300 MCM	70.0 mm ² (3/0 AWG)	19.5 N•m (173 lb•in)
	132...160	200...250	300 MCM	107.2 mm ² (4/0 AWG)	29.4 N•m (260 lb•in)
	200...250	300...350	500 MCM	300 MCM	40.0 N•m (354 lb•in)

(1) Maximum/minimum sizes that the terminal block will accept - these are not recommendations. If national or local codes require sizes outside the range, lugs may be used.

Control and Signal Wiring

See the PowerFlex 400 User Manual, publication [22C-UM001](#) for additional detailed information about control and signal wiring.

The Control I/O Terminal Block (TB1) and Relay Terminal Block (TB2) on the drive Main Control Board provide terminals for interfacing customer supplied control inputs and outputs. All analog and discrete control wiring will be made at these terminals. Typical customer control and signal wiring are shown on the Interconnect Drawings [Figure 8](#) on page [29](#) and [Figure 9](#) on page [30](#).

To connect control and signal wiring to the drive package:

- ❑ **1.** Wire the control and signal leads by routing them according to the drive option type. You must punch openings in the option cabinet of the desired conduit size, following NEC, and all applicable local codes and standards. I/O terminal block specifications are listed in [Table 4](#).

Control and signal wires should be separated from power wires by at least 0.3 meters (1 foot).

- ❑ **2.** Connect the control and signal wiring to the I/O terminals on the drive.
- ❑ **3.** Tighten the I/O terminals to the proper torque according to drive type as shown in [Table 4](#).

Table 4 - I/O Terminal Block Specifications

Voltage Rating	Maximum Wire Size ⁽¹⁾	Minimum Wire Size	Torque
208...460V AC	1.3 mm ² (16 AWG)	0.13 mm ² (26 AWG)	0.5...0.8 N·m (4.4...7 lb·in)

(1) Maximum/minimum sizes that the terminal block will accept - these are not recommendations.

Parameter Defaults (Style A/M)

Parameter Name	Number	Default
Output Freq	b001	Read Only
Commanded Freq	b002	Read Only
Output Current	b003	Read Only
Output Voltage	b004	Read Only
DC Bus Voltage	b005	Read Only
Drive Status	b006	Read Only
Fault 1 Code	b007	Read Only
Process Display	b008	Read Only
Output Power	b010	Read Only
Elapsed MWh	b011	Read Only
Elapsed Run Time	b012	Read Only
Torque Current	b013	Read Only
Drive Temp	b014	Read Only
Elapsed kWh	b015	Read Only
Motor NP Volts	P031	Drive Rated Volts
Motor NP Hertz	P032	60 Hz
Motor OL Current	P033	Drive Rated Amps
Minimum Freq	P034	0.0 Hz
Maximum Freq	P035	60 Hz
Start Source	P036	6 "2-W Lvl/Enbl" (1)
Stop Mode	P037	1 "Coast, CF"
Speed Reference	P038	2 "Analog In1"
Accel Time 1	P039	20.00 Secs
Decel Time 1	P040	20.00 Secs
Reset To Defaults	P041	0 "Ready/Idle"
Auto Mode	P042	1 "Hnd-Off-Auto"
Digital In1 Sel	T051	1 "Purge"
Digital In2 Sel	T052	3 "Local"
Digital In3 Sel	T053	10 "Clear Fault"
Digital In4 Sel	T054	4 "Comm Port"
Relay Out1 Sel	T055	0 "Ready/Fault"
Relay Out1 Level	T056	0.0
Relay 1 On Time	T058	0.0 Secs
Relay 1 Off Time	T059	0.0 Secs
Relay Out2 Sel	T060	2 "MotorRunning"
Relay Out2 Level	T061	0.0
Relay 2 On Time	T063	0.0 Secs
Relay 2 Off Time	T064	0.0 Secs
Opto Out Sel	T065	1 "At Frequency"
Opto Out Level	T066	0.0
Opto Out Logic	T068	0 "Normally Open"
Analog In 1 Sel	T069	2 "0-10V"
Analog In 1 Lo	T070	0.0%
Analog In 1 Hi	T071	100.0%
Analog In 1 Loss	T072	0 "Disabled"
Analog In 2 Sel	T073	1 "4-20 mA" (1)
Analog In 2 Lo	T074	0.0%
Analog In 2 Hi	T075	100.0%
Analog In 2 Loss	T076	0 "Disabled"
Sleep-Wake Sel	T077	0 "Disabled"
Sleep Level	T078	10.0%
Sleep Time	T079	0.0 Secs
Wake Level	T080	15.0%
Wake Time	T081	0.0 Secs
Analog Out1 Sel	T082	0 "OutFreq 0-10"
Analog Out1 High	T083	100%
Analog Out1 Setpt	T084	0.0%
Analog Out2 Sel	T085	1 "OutCurr 0-10"
Analog Out2 High	T086	100%
Analog Out2 Setpt	T087	0.0%
Language	C101	1 "English"
Comm Format	C102	0 "RTU 8-N-1"
Comm Data Rate	C103	3 "9600"
Comm Node Addr	C104	100
Comm Loss Action	C105	0 "Fault"
Comm Loss Time	C106	5.0 Secs

Parameter Name	Number	Default
Comm Write Mode	C107	0 "Save"
Purge Frequency	A141	5.0 Hz
Internal Freq	A142	60.00 Hz
Preset Freq 0	A143	0.0 Hz
Preset Freq 1	A144	5.0 Hz
Preset Freq 2	A145	10.0 Hz
Preset Freq 3	A146	20.0 Hz
Accel Time 2	A147	30.00 Secs
Decel Time 2	A148	30.00 Secs
S Curve%	A149	20%
PID Trim Hi	A150	60.0 Hz
PID Trim Lo	A151	0.0 Hz
PID Ref Sel	A152	0 "PID Disabled"
PID Feedback Sel	A153	0 "Analog In 1"
PID Prop Gain	A154	0.01
PID Integ Time	A155	2.0 Secs
PID Diff Rate	A156	0.00
PID Setpoint	A157	0.0%
PID Deadband	A158	0.0%
PID Preload	A159	0.0 Hz
Process Factor	A160	30.0
Auto Rstrt Tries	A163	0
Auto Rstrt Delay	A164	1.0 Secs
Start At PowerUp	A165	1 "Enabled" (1)
Reverse Disable	A166	1 "Rev Disabled"
Flying Start En	A167	1 "Enabled" (1)
PWM Frequency	A168	4.0 kHz
PWM Mode	A169	1 "2-Phase"
Boost Select	A170	4 "45.0, VT"
Start Boost	A171	2.5%
Break Voltage	A172	25.0%
Break Frequency	A173	15.0 Hz
Maximum Voltage	A174	Drive Rated Volts
Slip Hertz @ FLA	A175	2.0 Hz
DC Brake Time	A176	0.0 Secs
DC Brake Level	A177	Drive Rated Amps
DC Brk Time@Strt	A178	0 (Disabled)
Current Limit 1	A179	Drive Rated Amps
Current Limit 2	A180	Drive Rated Amps
Motor OL Select	A181	0 "No Derate"
Drive OL Mode	A182	3 "Both-PWM 1st"
SW Current Trip	A183	0.0 (Disabled)
Load Loss Level	A184	0.0 (Disabled)
Load Loss Time	A185	0 Secs
Stall Fault Time	A186	0 "60 Seconds"
Bus Reg Mode	A187	1 "Enabled"
Skip Frequency 1	A188	0 Hz
Skip Freq Band 1	A189	0.0 Hz
Skip Frequency 2	A190	0 Hz
Skip Freq Band 2	A191	0.0 Hz
Skip Frequency 3	A192	0 Hz
Skip Freq Band 3	A193	0.0 Hz
Compensation	A194	1 "Electrical"
Reset Meters	A195	0 "Ready/Idle"
Testpoint Sel	A196	400
Fault Clear	A197	0 "Ready/Idle"
Program Lock	A198	0 "Unlocked"
Motor NP Poles	A199	4
Relay Out3 Sel	R221	0 "Ready/Fault"
Relay Out3 Level	R222	0.0
Relay Out4 Sel	R224	0 "Ready/Fault"
Relay Out4 Level	R225	0.0
Relay Out5 Sel	R227	0 "Ready/Fault"
Relay Out5 Level	R228	0.0
Relay Out6 Sel	R230	0 "Ready/Fault"
Relay Out6 Level	R231	0.0
Relay Out7 Sel	R233	0 "Ready/Fault"
Relay Out7 Level	R234	0.0
Relay Out8 Sel	R236	0 "Ready/Fault"

Parameter Name	Number	Default
Relay Out8 Level	R237	0.0
Aux Motor Mode	R239	0 "Disabled"
Aux Motor Qty	R240	1 "1 Aux Mtr"
Aux 1 Start Freq	R241	50.0 Hz
Aux 1 Stop Freq	R242	25.0 Hz
Aux 1 Ref Add	R243	0.0%
Aux 2 Start Freq	R244	50.0 Hz
Aux 2 Stop Freq	R245	25.0 Hz
Aux 2 Ref Add	R246	0.0%
Aux 3 Start Freq	R247	50.0 Hz
Aux 3 Stop Freq	R248	25.0 Hz
Aux 3 Ref Add	R249	0.0%
Aux Start Delay	R250	5.0 Secs
Aux Stop Delay	R251	3.0 Secs
Aux Prog Delay	R252	0.50 Secs
Aux AutoSwap Time	R253	0.0 Hr
Aux AutoSwap Lvl	R254	50.0%
Control Source	d301	Read Only
Contrl In Status	d302	Read Only
Comm Status	d303	Read Only
PID Setptn Displ	d304	Read Only
Analog In 1	d305	Read Only
Analog In 2	d306	Read Only
Fault 1 Code	d307	Read Only
Fault 2 Code	d308	Read Only
Fault 3 Code	d309	Read Only
Fault 1 Time-hr	d310	Read Only
Fault 1 Time-min	d311	Read Only
Fault 2 Time-hr	d312	Read Only
Fault 2 Time-min	d313	Read Only
Fault 3 Time-hr	d314	Read Only
Fault 3 Time-min	d315	Read Only
Elapsed Time-hr	d316	Read Only
Elapsed Time-min	d317	Read Only
Output Powr Fctr	d318	Read Only
Testpoint Data	d319	Read Only
Control SW Ver	d320	Read Only
Drive Type	d321	Read Only
Output Speed	d322	Read Only
Output RPM	d323	Read Only
Fault Frequency	d324	Read Only
Fault Current	d325	Read Only
Fault Bus Volts	d326	Read Only
Status @ Fault	d327	Read Only

(1) The default values of these parameters differ from Factory Defaults. Setting P041 [Reset To Defaults] to 1 "Factory Reset" will change these parameter settings to the defaults list in the PowerFlex 400 User Manual, publication [22C-UM001](#).



ATTENTION: Parameter A165 [Start At PowerUp] ships from the factory enabled. This feature allows a Run command to automatically cause the drive to resume running at commanded speed after drive input power is restored. Equipment damage and/or personal injury may result if this parameter is used in an inappropriate application. Do not use this function without considering applicable local, national, and international codes, standards, regulations or industry guidelines.

Drawing Index

208V AC Input – Main Input Disconnect Drive Packages (Style A/M)

Input Voltage	Type	Hp	Input Line Reactor	Drawing				Hp	Style															
				SchematicPage		InterconnectPage				LayoutPage	OutlinePage													
208V AC	NEMA/UL Type 1	3	No	98D00697	22	97D00696	29	95D00758	34	95D00689	70	3	A											
		5										5												
		7.5										7.5												
		10										10												
		15										15												
		20										20												
		25										25												
		30										30												
		40										40												
		50										50												
		3										Yes		98D00756	23	97D00754	30	95D00791	42	95D00690	78	3		
		5																				5		
		7.5																				7.5		
		10																				10		
		15																				15		
	20	20																						
	25	25																						
	30	30																						
	40	40																						
	50	50																						
	3	NEMA/UL Type 12	With or Without	98D01535	26	97D01548	33	95D01575	48	95D01576	49		95D01552									84	3	A & M
	5																						5	
	7.5																						7.5	
	10																						10	
	15																						15	
	20											20												
	25	25																						
	30	30																						
	40	40																						
	50	50																						
3	NEMA/UL Type 4	With or Without	98D01537	27	97D01548	33	95D01563	56	95D01565	57	95D01551	85	3											
5													5											
7.5													7.5											
10													10											
15													15											
20													20											
25	25																							
30	30																							
40	40																							
50	50																							
3	NEMA/UL Type 3R	With or Without	98D01535	26	97D01548	33	95D01553	63	95D01554	64	95D01550	86	3											
5													5											
7.5													7.5											
10													10											
15													15											
20													20											
25	25																							
30	30																							
40	40																							
50	50																							

460V AC – Main Input Disconnect Drive Packages (Style A/M)

Input Voltage	Type	Hp	Input Line Reactor	Drawing				Hp	Style							
				SchematicPage	InterconnectPage	LayoutPage	OutlinePage									
460V AC	NEMA/UL Type 1	3	No					3	A							
		5						5								
		7.5						7.5								
		10						10								
		15						15								
		20						20								
		25						25								
		30						30								
		40						40								
		50						50								
		60						60								
		75						75								
		100						100								
		125						125								
		150						150								
					200		98D00697	22	97D00696	29	95D00758	34	95D00689	70	200	
					250										250	
					300		98D01888	24	97D01890	31	95D00759	35	95D00691	71	300	
					350		98D01887	25	97D01889	32	95D00760	37	95D00693	73	350	
					3										3	
					5										5	
					7.5						95D00791	42	95D00690	78	7.5	
					10										10	
					15										15	
					20						95D00792	43	95D00753	79	20	
					25										25	
					30		98D00756	23	97D00754	30	95D01367	44	95D01359	80	30	A
					40										40	
					50										50	
					60										60	
					75						95D01369	46	95D01361	82	75	
					100										100	
					125										125	
					150						95D01370	47	95D01362	83	150	
					3										3	
		5										5				
		7.5						95D01575	48			7.5				
		10										10				
		15										15				
		20										20				
		25										25				
		30	With or Without	98D01535	26	97D01548	33	95D01576	49	95D01552	84	30	A & M			
		40										40				
		50										50				
		60						95D02470	52			60				
		75										75				
		100						95D02476	53			100				
		125										125				
		150						95D01579	54			150				

Input Voltage	Type	Hp	Input Line Reactor	Drawing				Hp	Style
				SchematicPage	InterconnectPage	LayoutPage	OutlinePage		
460V AC	NEMA/UL Type 4	3	With or Without	98D01537 27	97D01548 33	95D02442 55	95D01551 85	3	A & M
		5				5			
		7.5				7.5			
		10				10			
		15				15			
		20				20			
		25				25			
		30				30			
		40				40			
		50				50			
		60				60			
		75				75			
		100				100			
		125				125			
	150	150							
	NEMA/UL Type 3R	With or Without	98D01535 26	97D01548 33	95D01553 63	95D01550 86	3		
					5		5		
					7.5		7.5		
					10		10		
					15		15		
					20		20		
					25		25		
					30		30		
					40		40		
					50		50		
					60		60		
					75		75		
					100		100		
125					125				
150	150								

Schematic Drawings

Figure 1 - 3.0...50 Hp, 208V AC and 3.0...150 Hp, 460V AC Drives - NEMA/UL Type 1

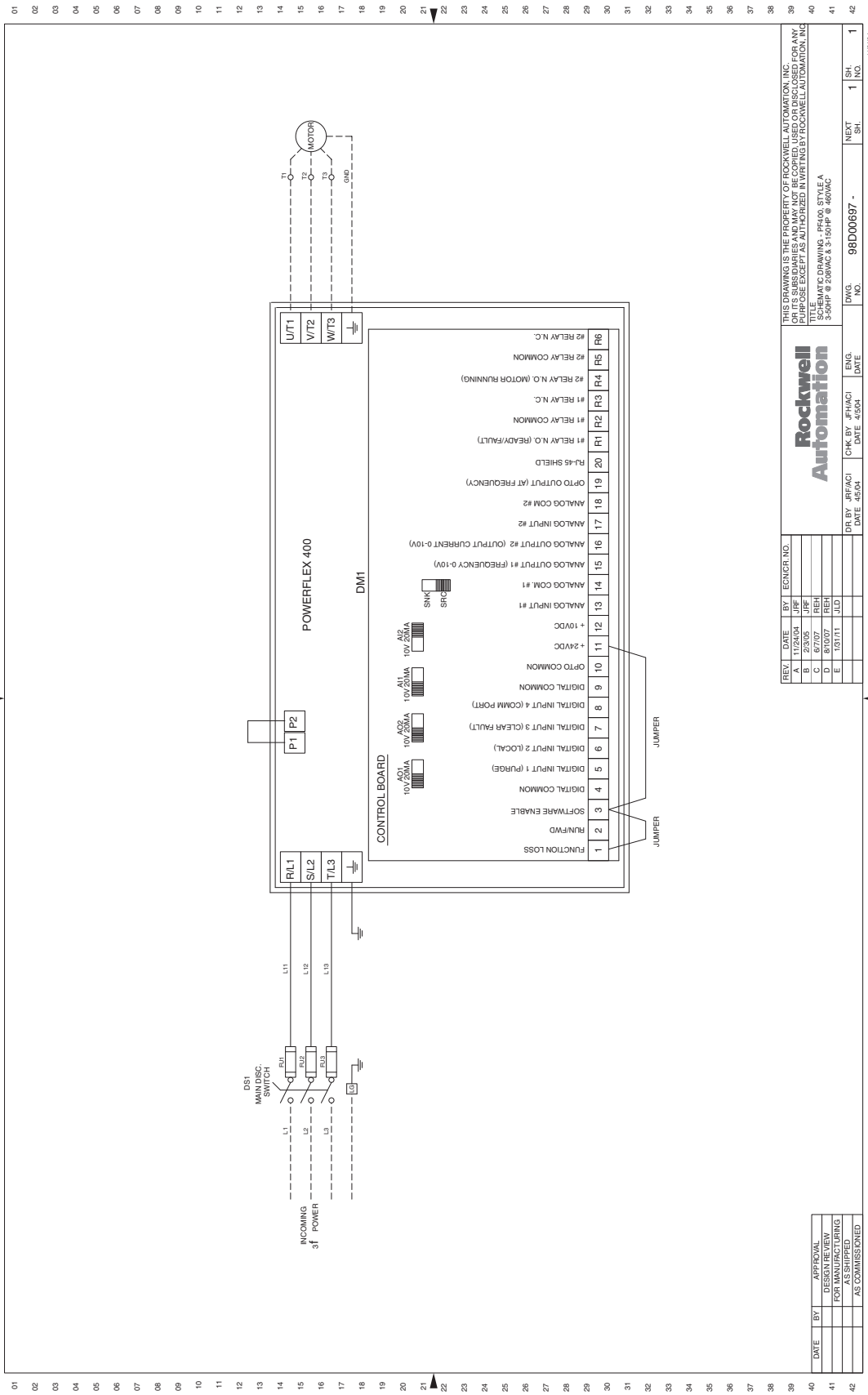

Figure 2 - 3.0...50 Hp, 208V AC and 3.0...150 Hp, 460V AC Drives with Line Reactor - NEMA/UL Type 1

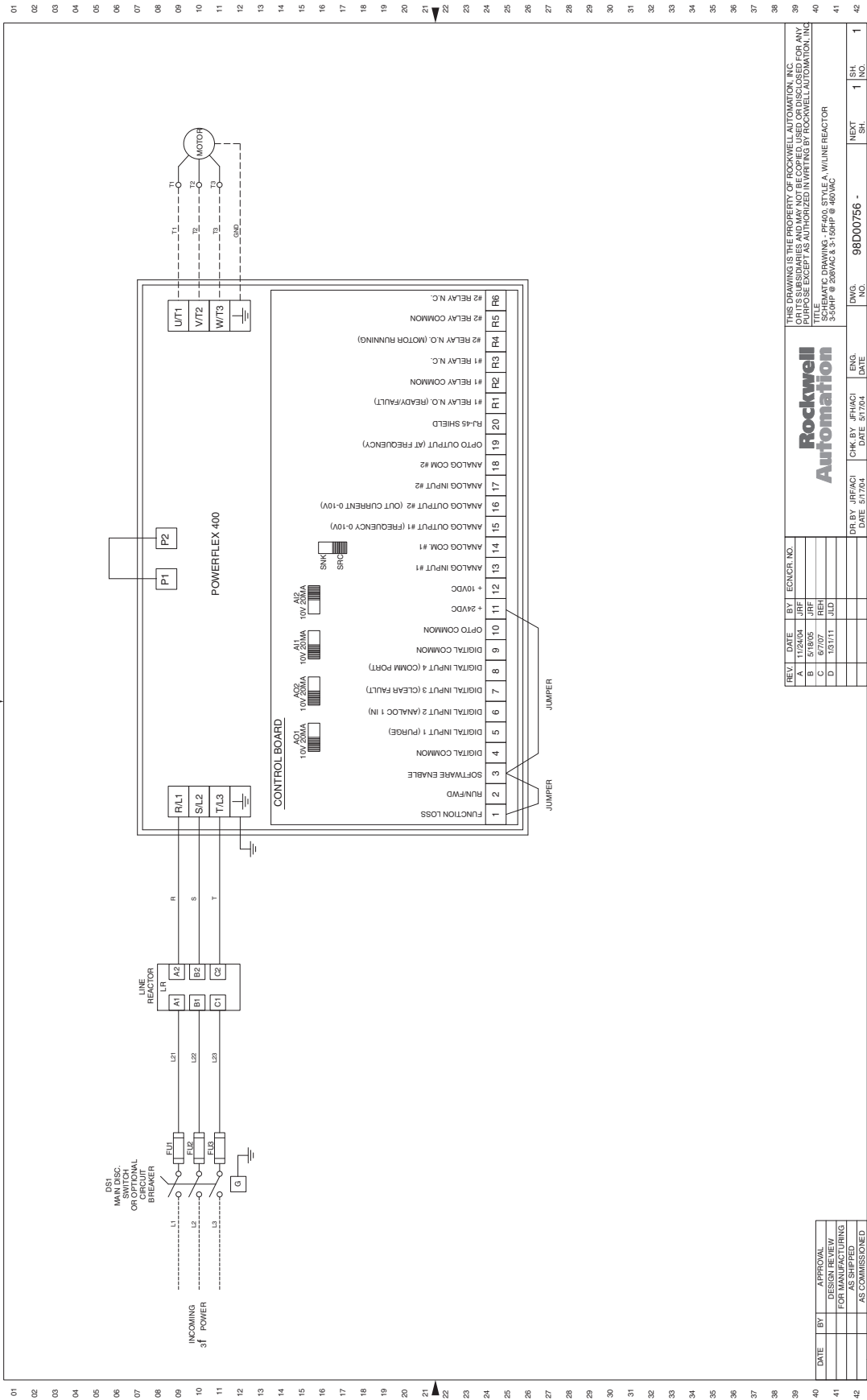
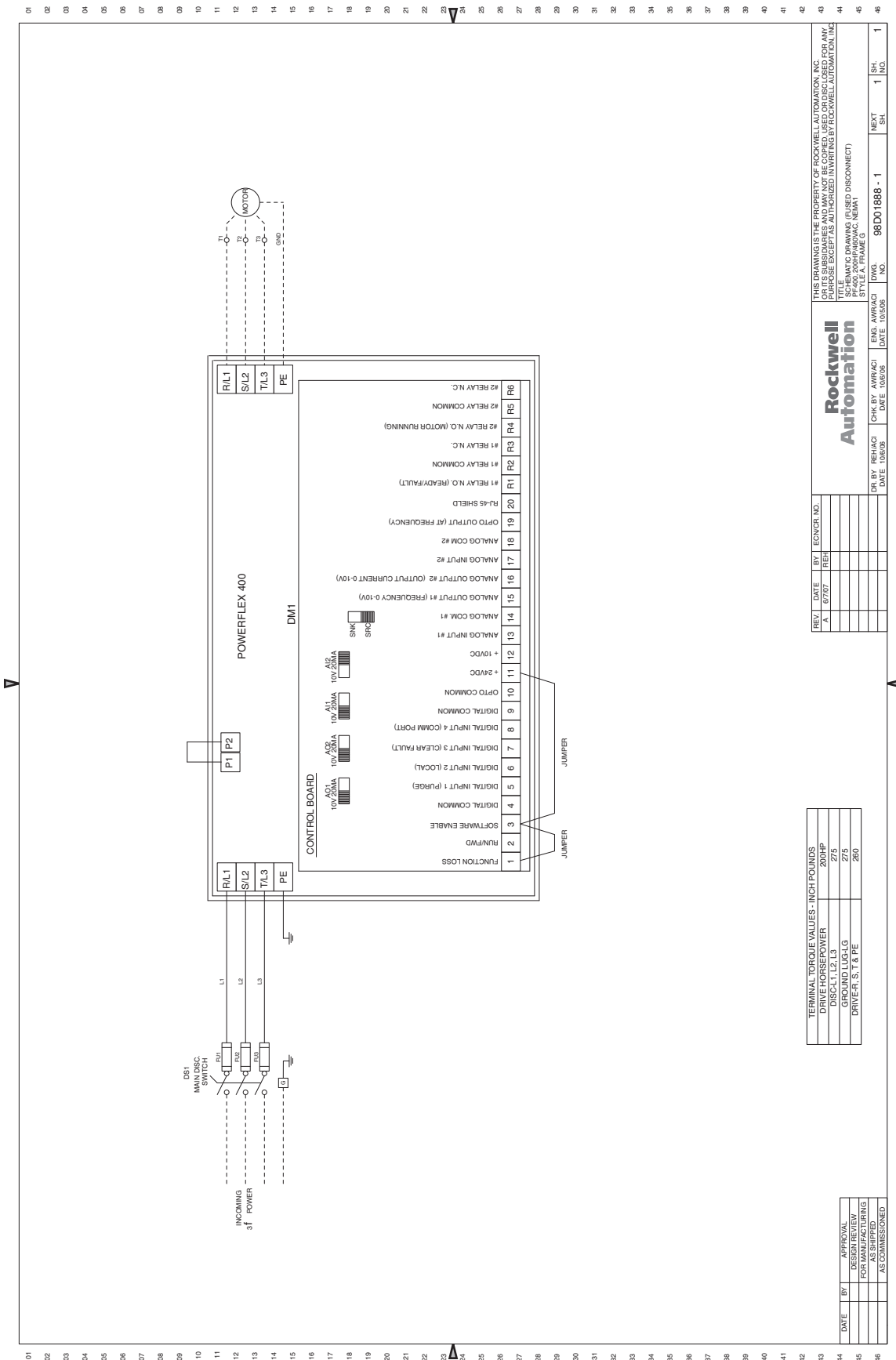

Figure 3 - 200 Hp, 460V AC Drives - NEMA/UL Type 1



TERMINAL TORQUE VALUES - INCH-POUNDS

DRIVE HORSEPOWER	200HP
DISC L1, L2, L3	275
ROUND LUG L3	275
DRIVE T, S1, & T2	280

DATE	BT	APPROVAL
		DESIGN REVIEW
		FOR MANUFACTURING
		AS SHIPPED
		AS COMMISSIONED

REV.	DATE	BY	ECNOR. NO.
A	6/7/07	REH	

Rockwell Automation

DR BY: REH/ACI	DATE: 10/6/09	CHK BY: AMR/ACI	DATE: 10/6/09	ENG. AWR/HAC	DATE: 10/3/06	DWG. NO.	98D01889 - 1	NEXT SH.	1	SH. NO.	1
----------------	---------------	-----------------	---------------	--------------	---------------	----------	--------------	----------	---	---------	---

THIS DRAWING IS THE PROPERTY OF ROCKWELL AUTOMATION, INC. OR ITS SUBSIDIARIES AND MAY NOT BE COPIED, USED OR DISCLOSED FOR ANY PURPOSES EXCEPT AS AUTHORIZED IN WRITING BY ROCKWELL AUTOMATION, INC.

SCHEMATIC DRAWING (FUSED DISCONNECT)

STYLE A FRAME G

Figure 4 - 250...350 Hp, 460V AC Drives - NEMA/UL Type 1

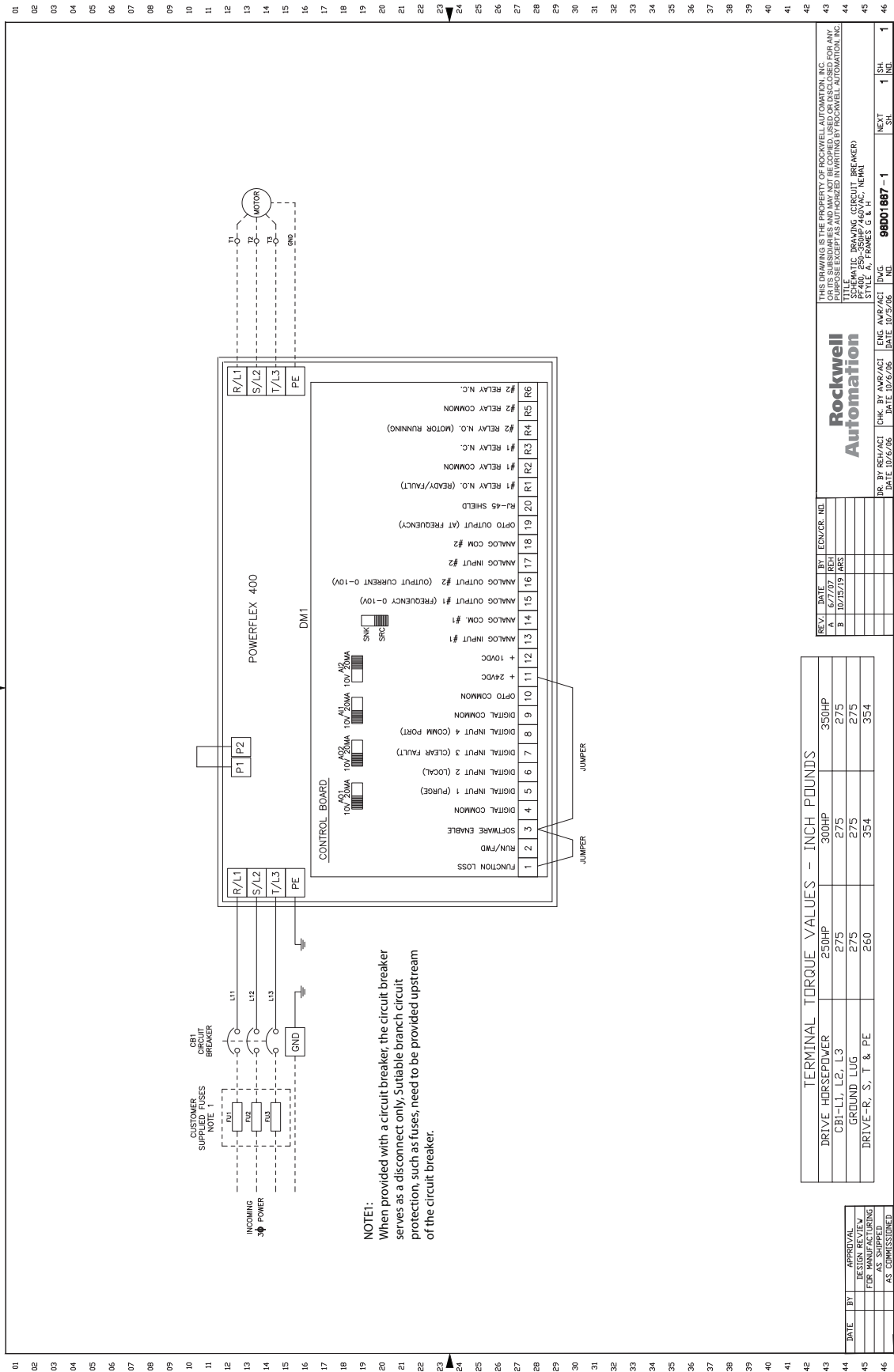
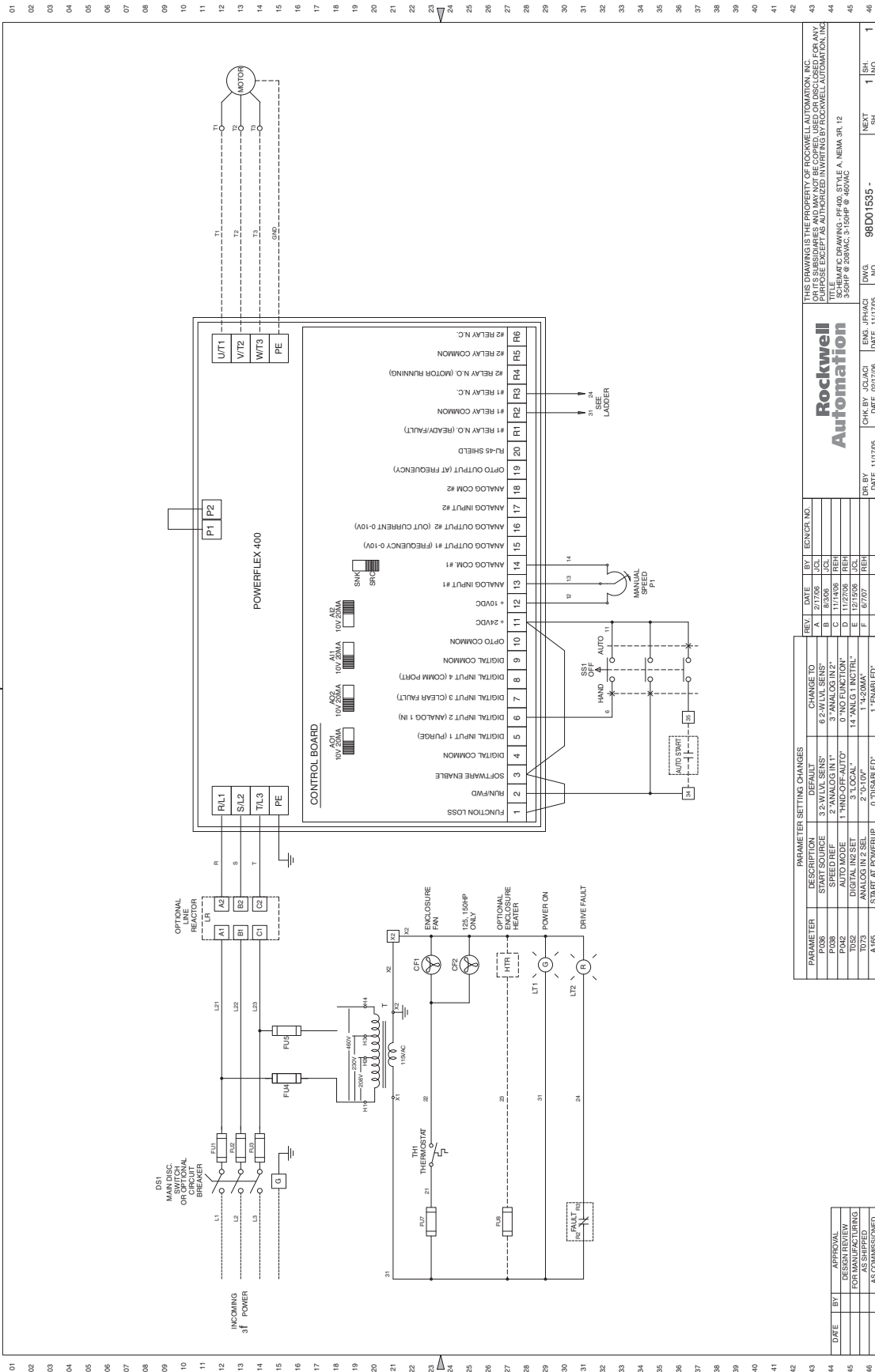

Figure 5 - 3.0...50 Hp, 208V AC and 3.0...150 Hp, 460V AC Drives - NEMA/UL Type 12 and 3R



REV.	DATE	BY	REASON NO.
A	2/17/06	JCL	
B	8/5/06	JCL	
C	12/27/06	JCL	
D	12/27/06	BEH	
E	12/15/06	JCL	
F	6/7/07	BEH	

PARAMETER	DESCRIPTION	DEFAULT	CHANGE TO
SPD	SPEED REF	3.0 VDC	0 "NO FUNCTION"
SPD	SPEED REF	2 "ANALOG IN 2"	3 "ANALOG IN 2"
SPD	SPEED REF	1 "HAND-OFF-AUTO"	0 "NO FUNCTION"
TRQ	DIGITAL IN 2 SET	3 "LOCAL"	14 "ANLG 1 INCTRL"
TRQ	ANALOG IN 2 SET	2 "0.10V"	1 "0.20V"
TRQ	START AT POWERUP	0 "DISABLED"	1 "ENABLED"

APPROVAL	DATE	BY	REASON
DESIGN REVIEW			
FOR MANUFACTURING			
AS SHIPPED			
AS COMMISSIONED			

DR BY	JCL/ACI	ENG. JFH/ACI	DATE 11/17/06	DWG. NO. 98D01535 -	REV. NO.	SH. NO.	IN. NO.

Figure 6 - 3.0...50 Hp, 208V AC and 3.0...100 Hp, 460V AC Drives - NEMA/UL Type 4

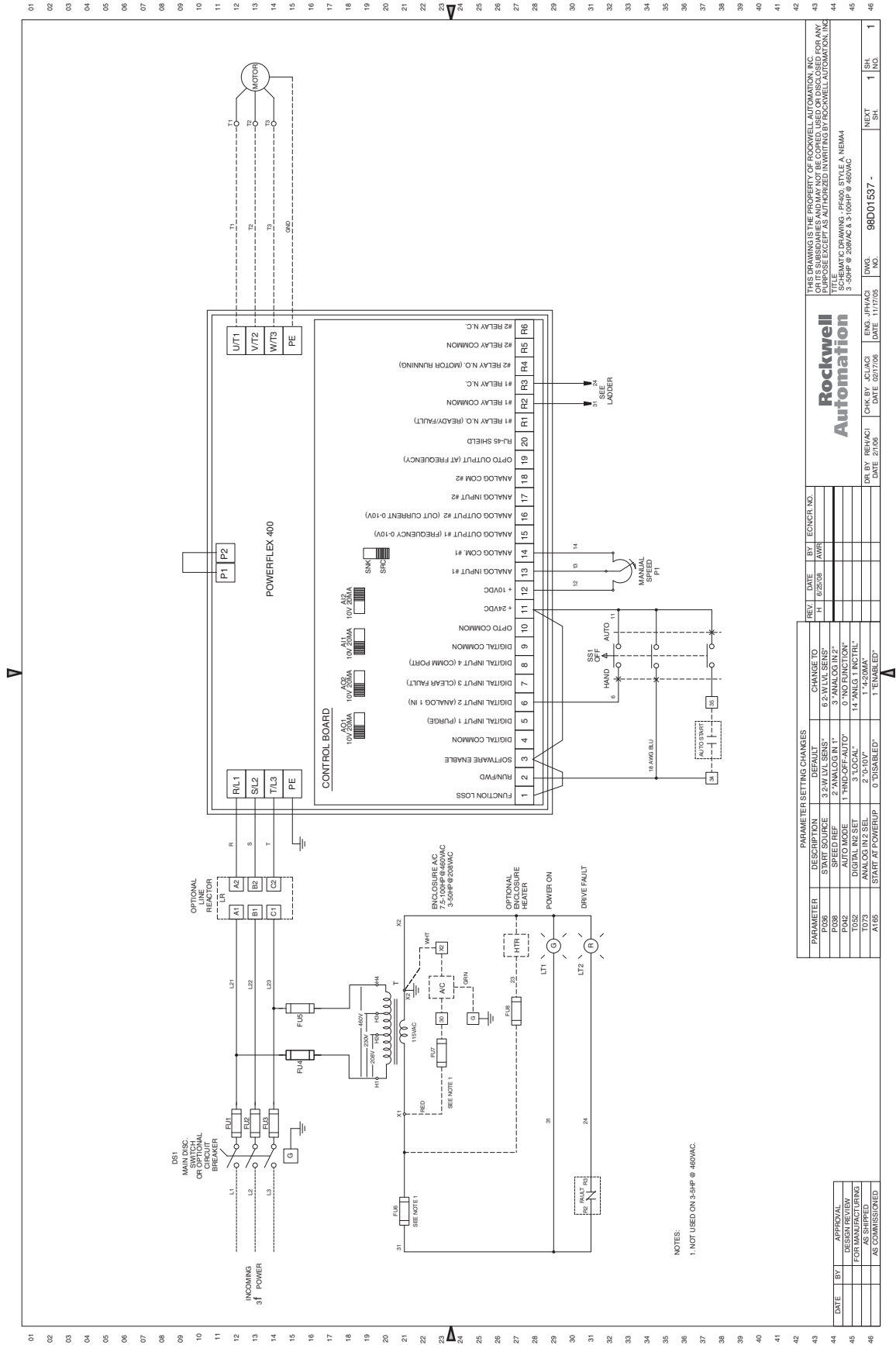
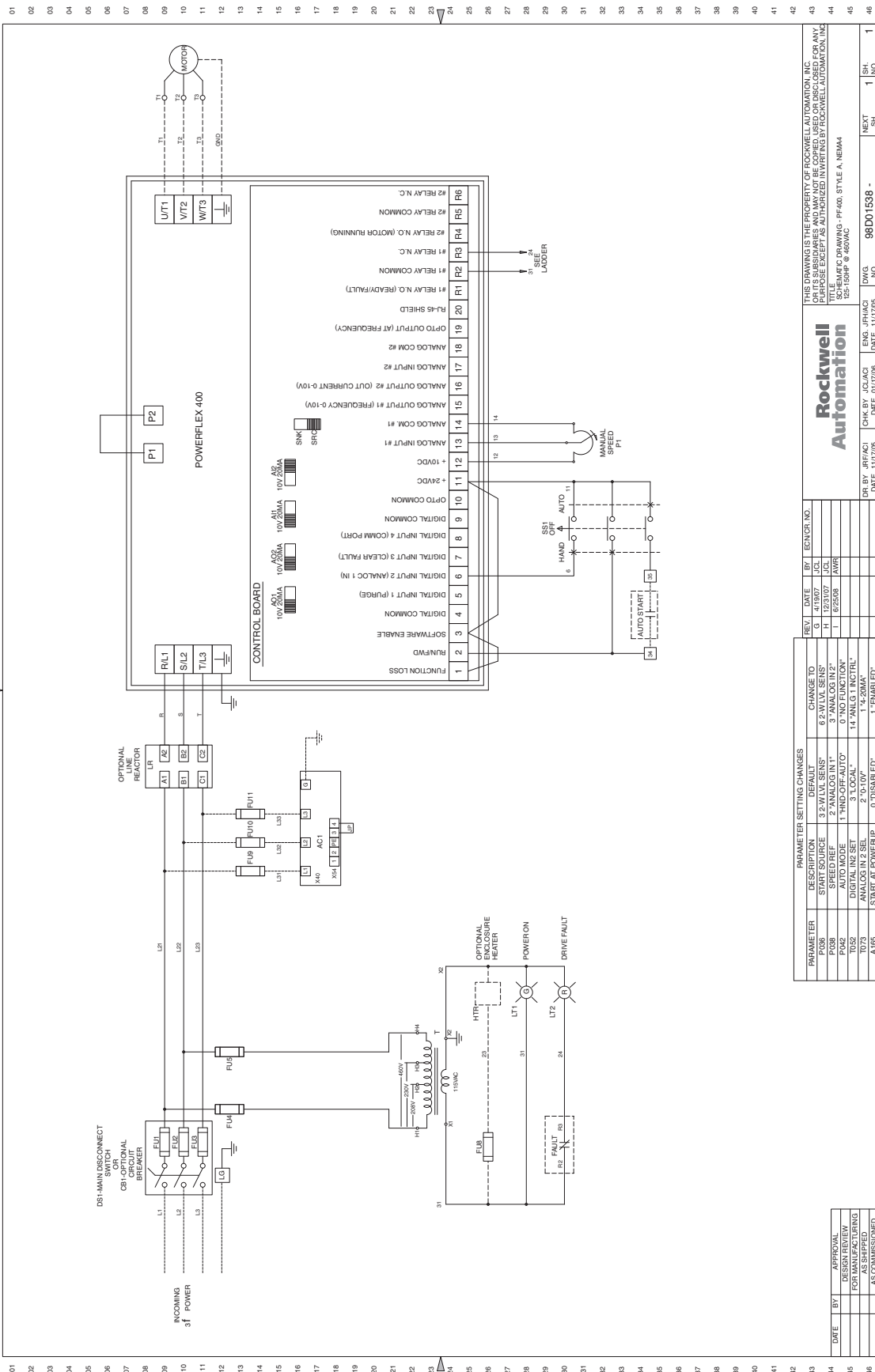

Figure 7 - 125...150 Hp, 460V AC Drives - NEMA/UL Type 4



REV.	DATE	BY	ENCR. NO.
G	4/18/07	JCL	
H	12/31/07	JCL	
I	8/28/08	AWR	

DR BY: JRF/ACI DATE: 11/17/08
 ENL: JPH/ACI DATE: 11/17/08
 DWG. NO.: 98D01538 - 1
 NEXT SH. NO. 1

THIS DRAWING IS THE PROPERTY OF ROCKWELL AUTOMATION, INC. OR ITS SUBSIDIARIES AND MAY NOT BE COPIED, USED OR DISCLOSED FOR ANY TITLE UNLESS EXCEPT AS AUTHORIZED IN WRITING BY ROCKWELL AUTOMATION, INC.
 SCHEMATIC DRAWING - PF400, STYLE A, NEMA4
 125-150HP #460VAC

Interconnect Drawings

Figure 8 - 3.0...50 Hp, 208V AC and 3.0...150 Hp, 460V AC Drives - NEMA/UL Type 1

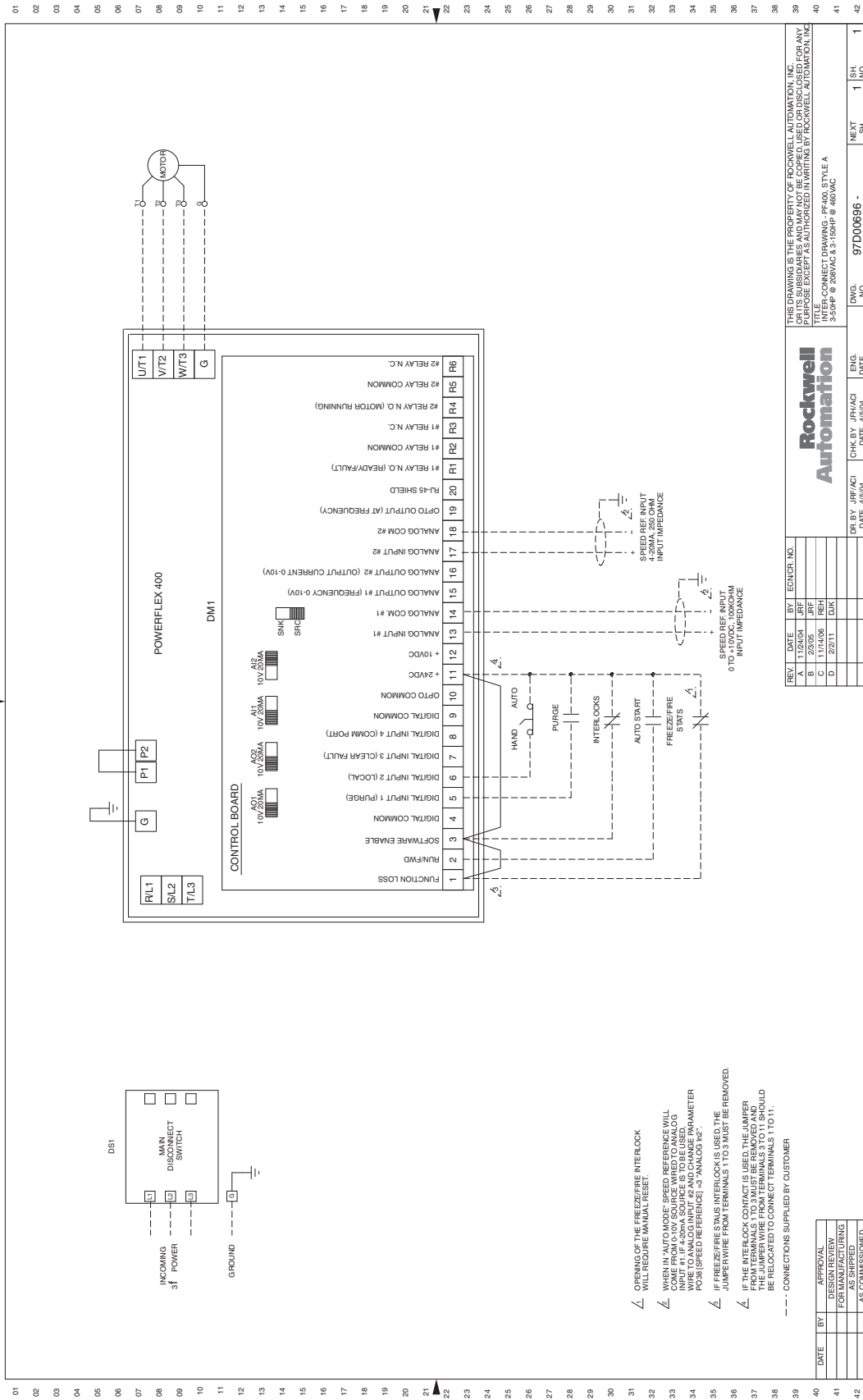

Figure 9 - 3.0...50 Hp, 208V AC and 3.0...150 Hp, 460V AC Drives with Line Reactor - NEMA/UL Type 1

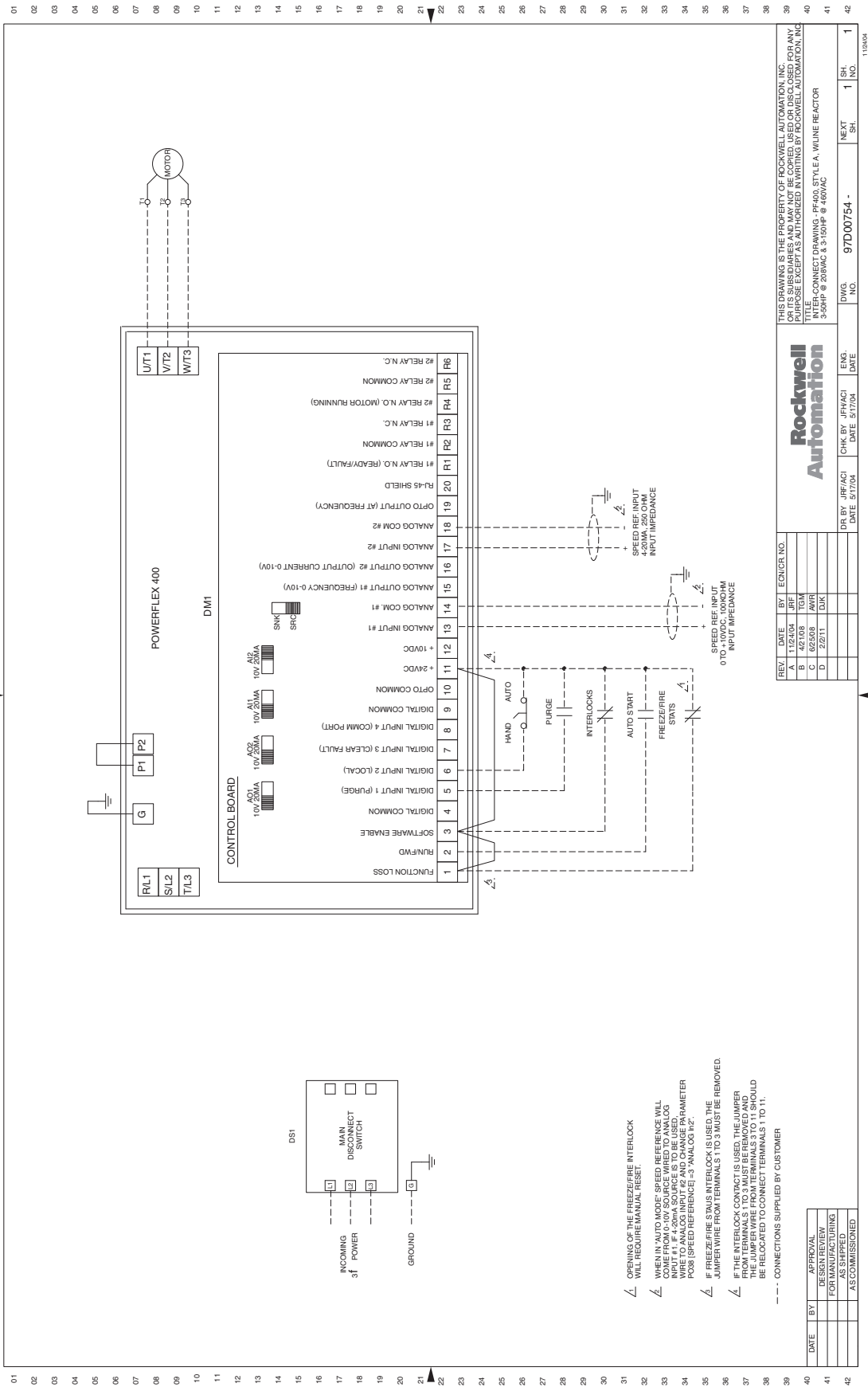

Figure 10 - 200 Hp, 460V AC Drives - NEMA/UL Type 1

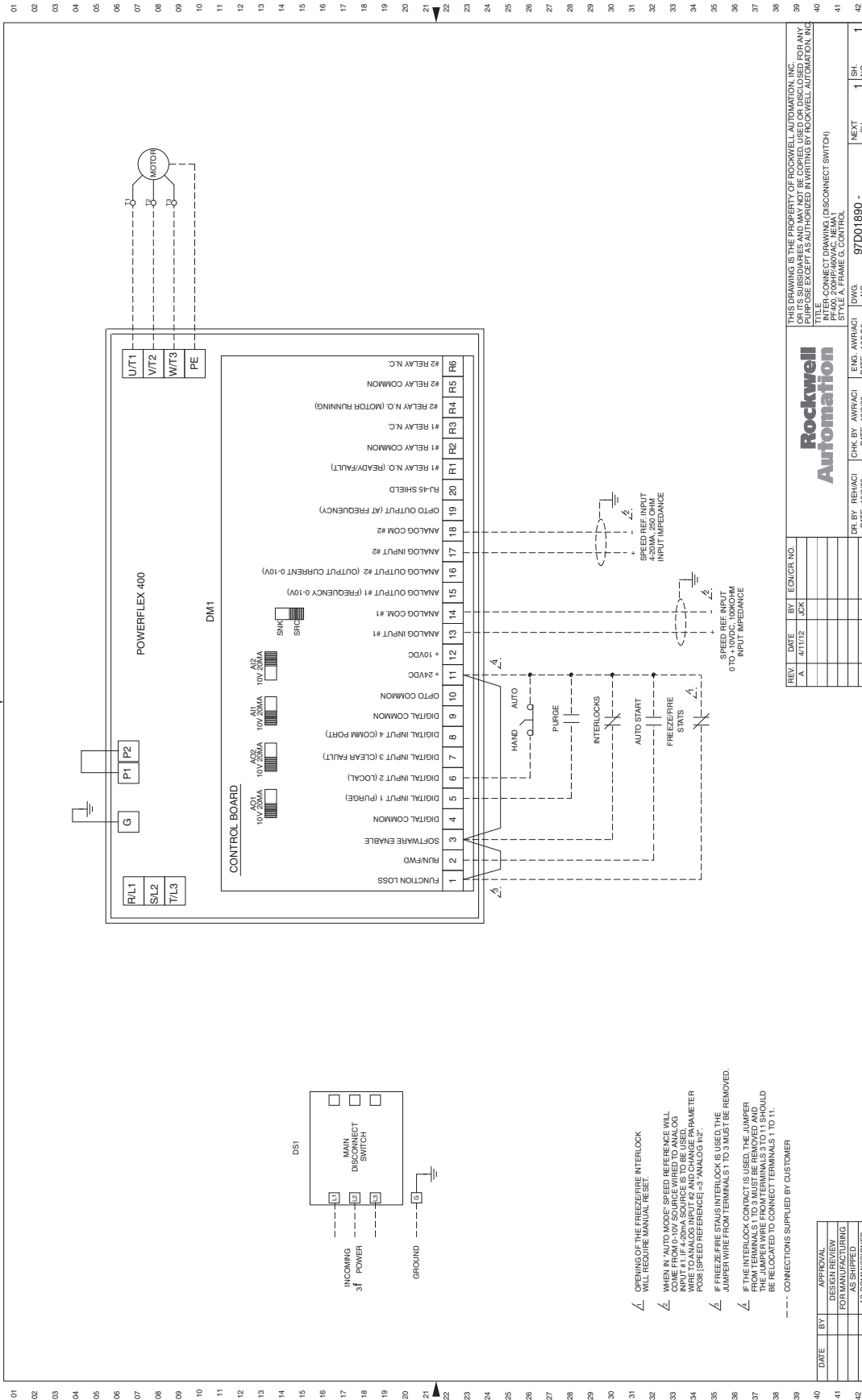

Figure 11 - 250...350 Hp, 460V AC Drives - NEMA/UL Type 1

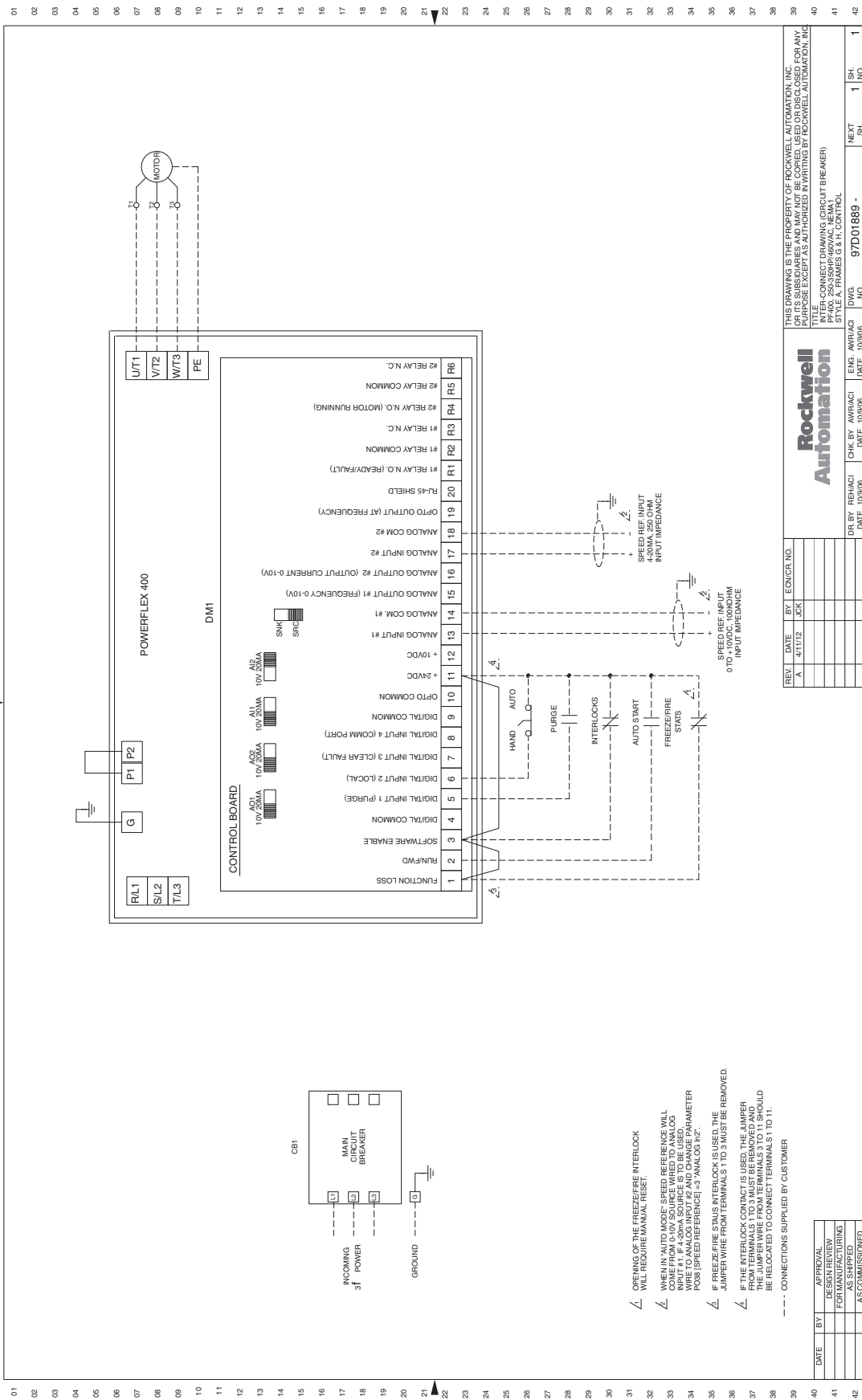
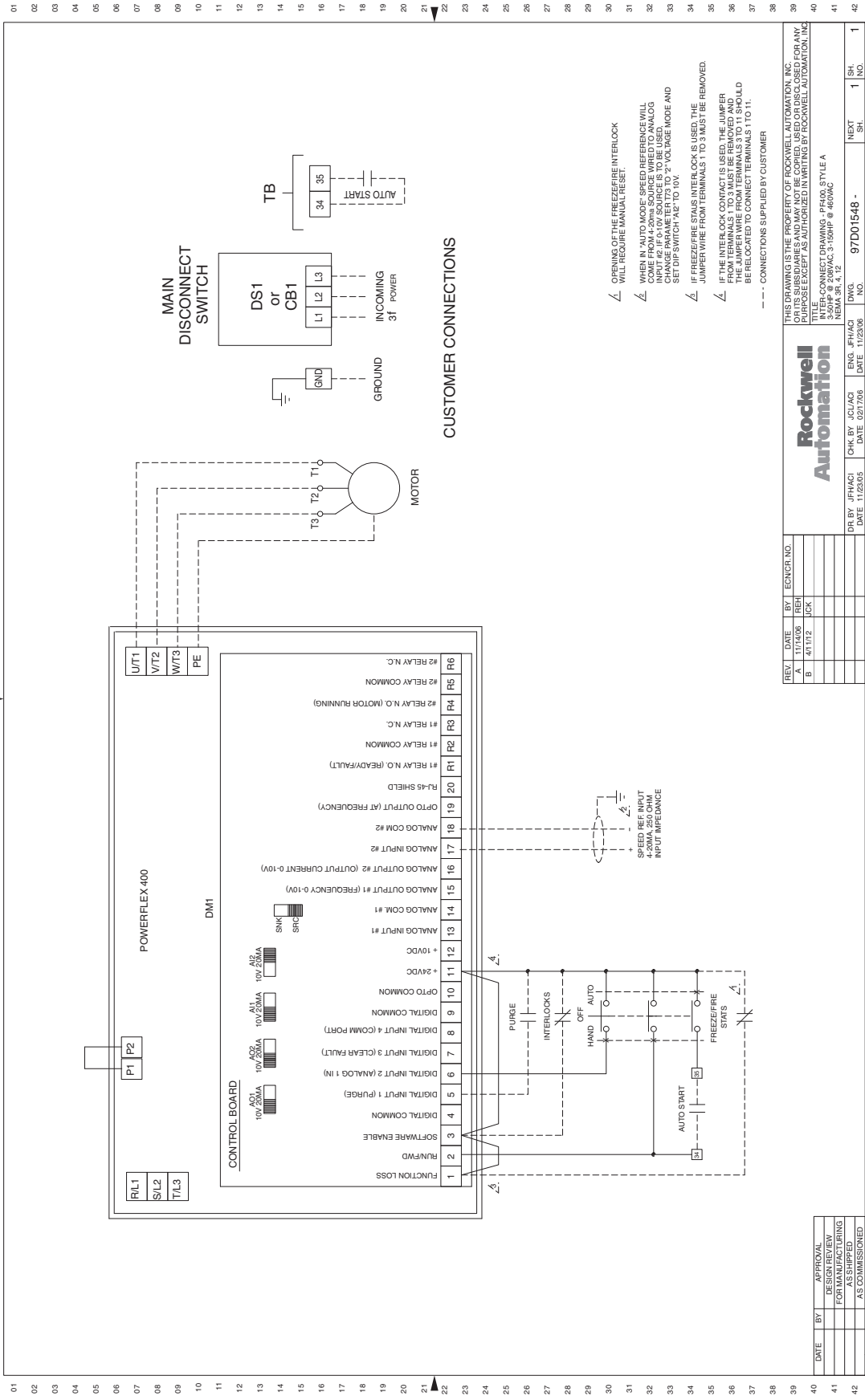

Figure 12 - 3.0...50 Hp, 208V AC and 3.0...150 Hp, 460V AC Drives - NEMA/UL Type 12, 4, and 3R



Layout Drawings

Figure 13 - 3.0...10 Hp, 208V AC and 3.0...20 Hp, 460V AC Drives - NEMA/UL Type 1

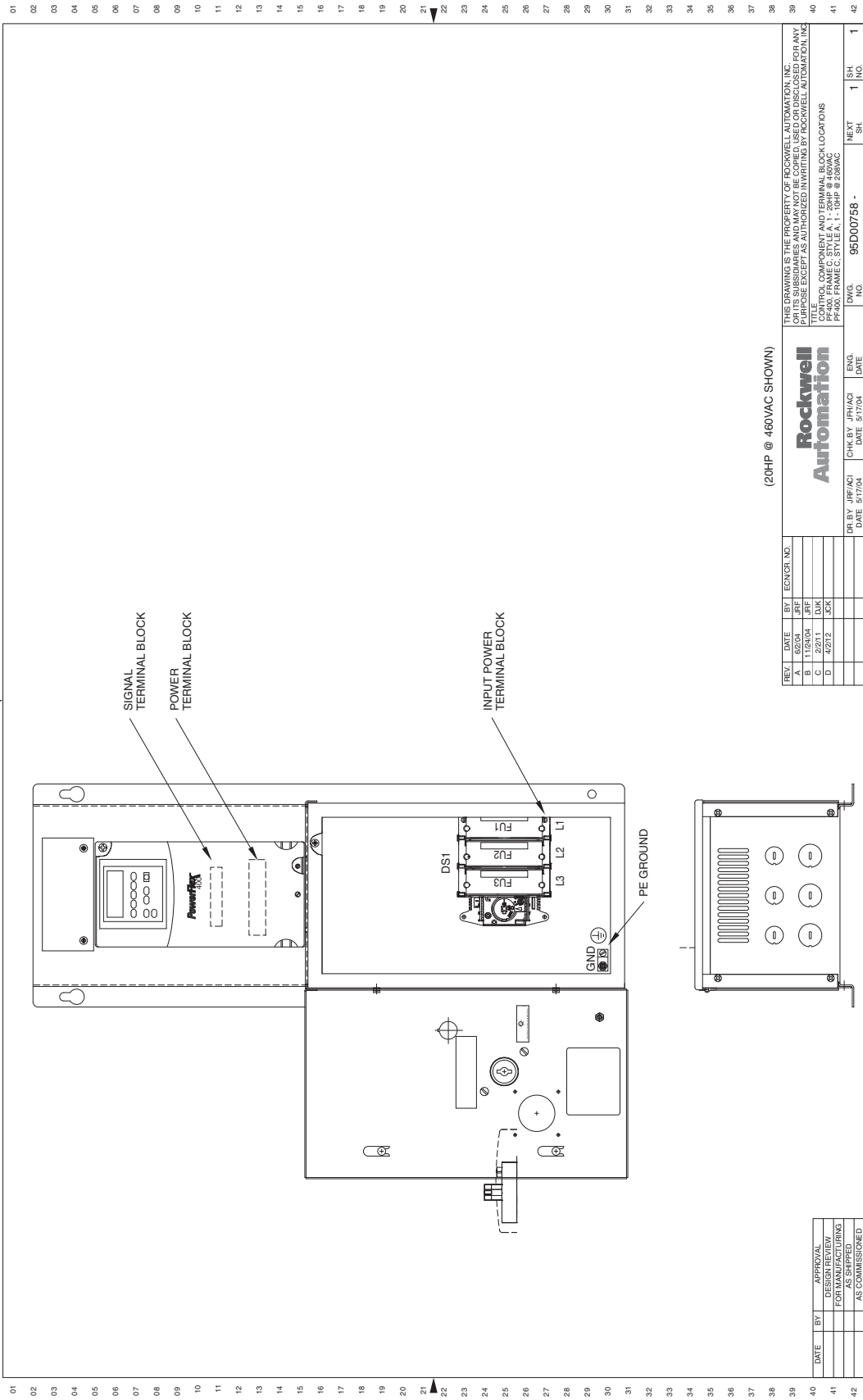

Figure 14 - 15...20 Hp, 208V AC and 25...40 Hp, 460V AC Drives - NEMA/UL Type 1

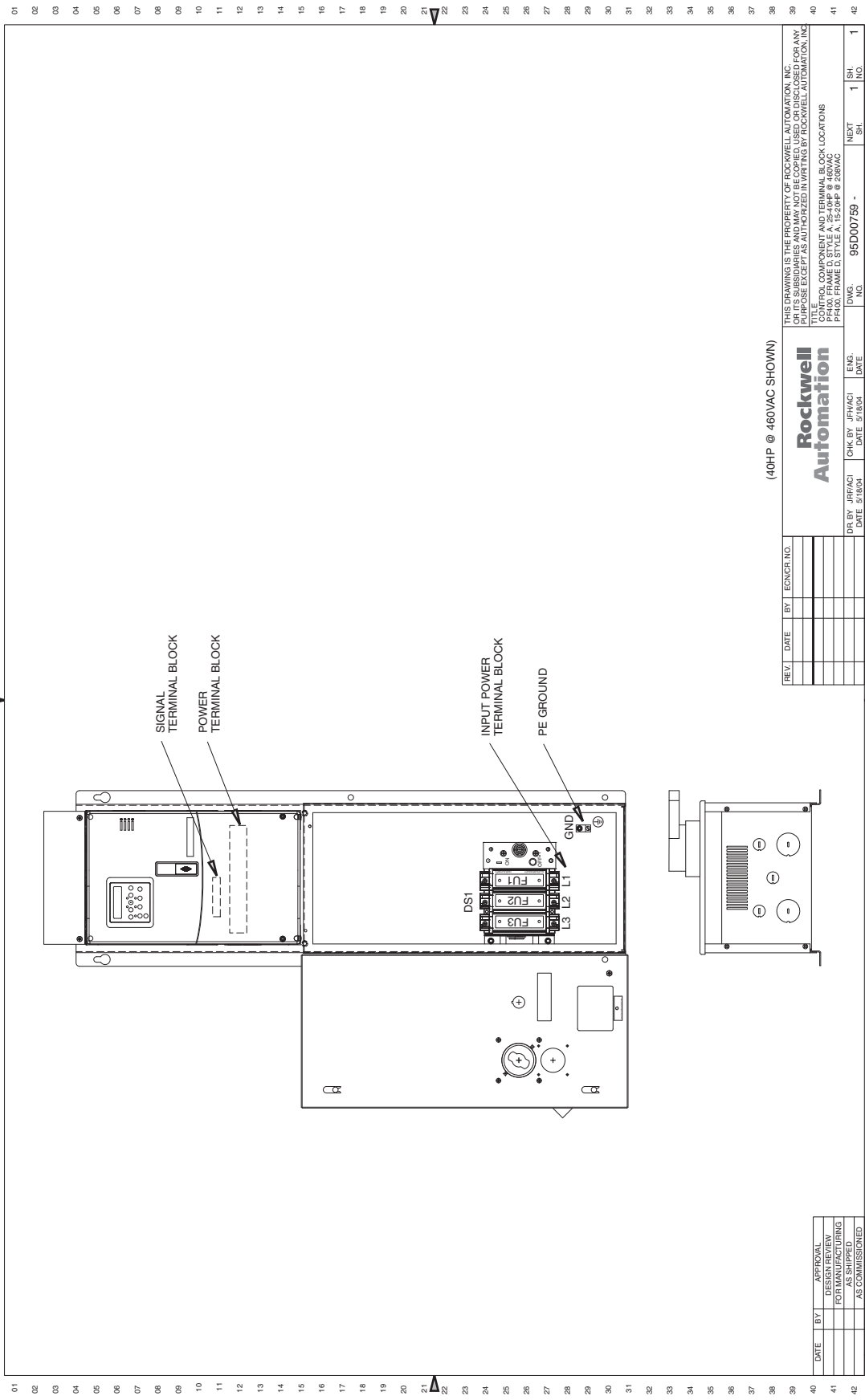
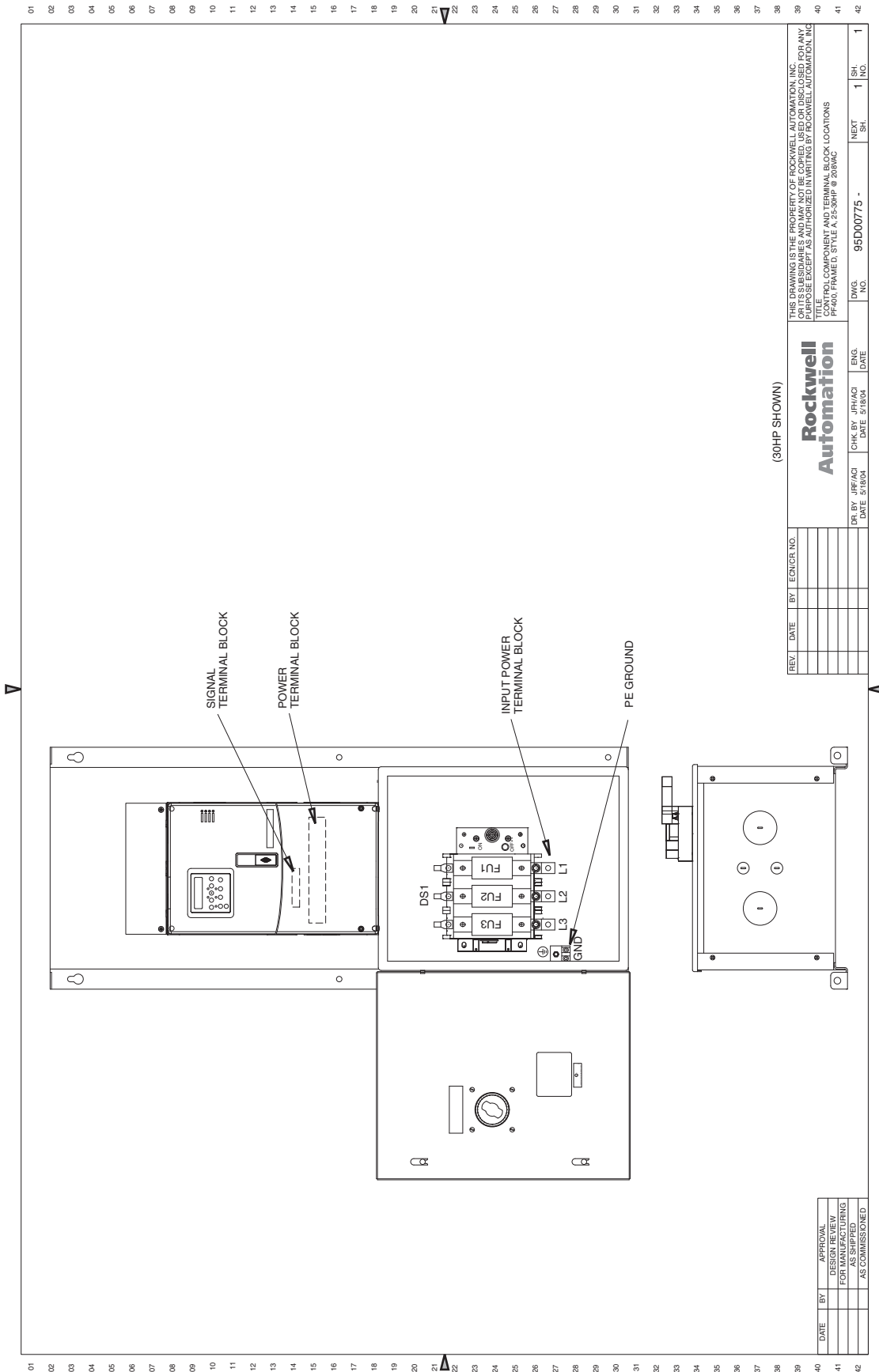

Figure 15 - 25...30 Hp, 208V AC Drives - NEMA/UL Type 1



01
02
03
04
05
06
07
08
09
10
11
12
13
14
15
16
17
18
19
20
21
22
23
24
25
26
27
28
29
30
31
32
33
34
35
36
37
38
39
40
41
42

(30HP SHOWN)

REV		DATE	BY	ECNCR NO.	<p>THIS DRAWING IS THE PROPERTY OF ROCKWELL AUTOMATION, INC. FOR ANY PURPOSE EXCEPT AS AUTHORIZED IN WRITING BY ROCKWELL AUTOMATION, INC.</p> <p>TITLE: I/O COMPONENT AND TERMINAL BLOCK LOCATIONS</p> <p>PART: PF400, FRAMEID, STYLE A, 25-30HP @ 208VAC</p>
					DWG. NO. 95D00775 - ENG. DATE CHK BY: JIR/ACI DATE: 3/18/01 DR BY: JIR/ACI DATE: 3/18/01 NEXT SHI 1 S.I. NO. 1

Figure 16 - 40 Hp, 208V AC and 50...100 Hp, 460V AC Drives - NEMA/UL Type 1

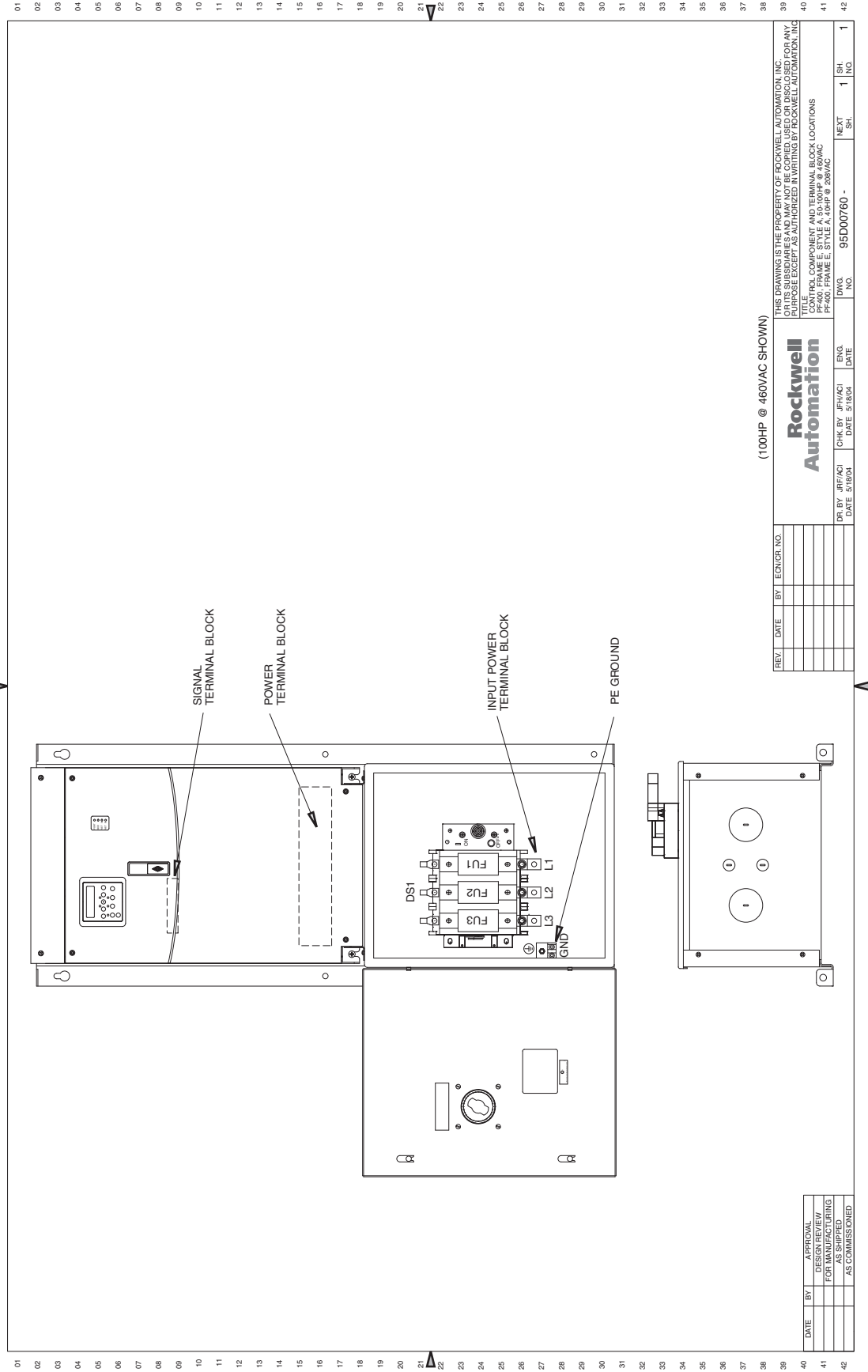

(100HP @ 460VAC SHOWN)

REV.	DATE	BY	ECNOR. NO.	THIS DRAWING IS THE PROPERTY OF ROCKWELL AUTOMATION, INC. OR ITS SUBSIDIARIES AND MAY NOT BE COPIED, USED OR DISCLOSED FOR ANY PURPOSES WITHOUT THE WRITTEN PERMISSION OF ROCKWELL AUTOMATION, INC.	
				Rockwell Automation TITLE: COMPENSATIVE AND TERMINAL BLOCK LOCATIONS CONT. FILE NO.: 95D00760 - 1 PART NO.: PF400, FRAME E, STYLE A, 10HP @ 208VAC	
				DWG. NO.	95D00760 - 1
				NO.	1
				SH.	1
				NO.	1
				SH.	1
				NO.	1
				SH.	1
				NO.	1
				SH.	1

Figure 17 - 50 Hp, 208V AC Drives - NEMA/UL Type 1

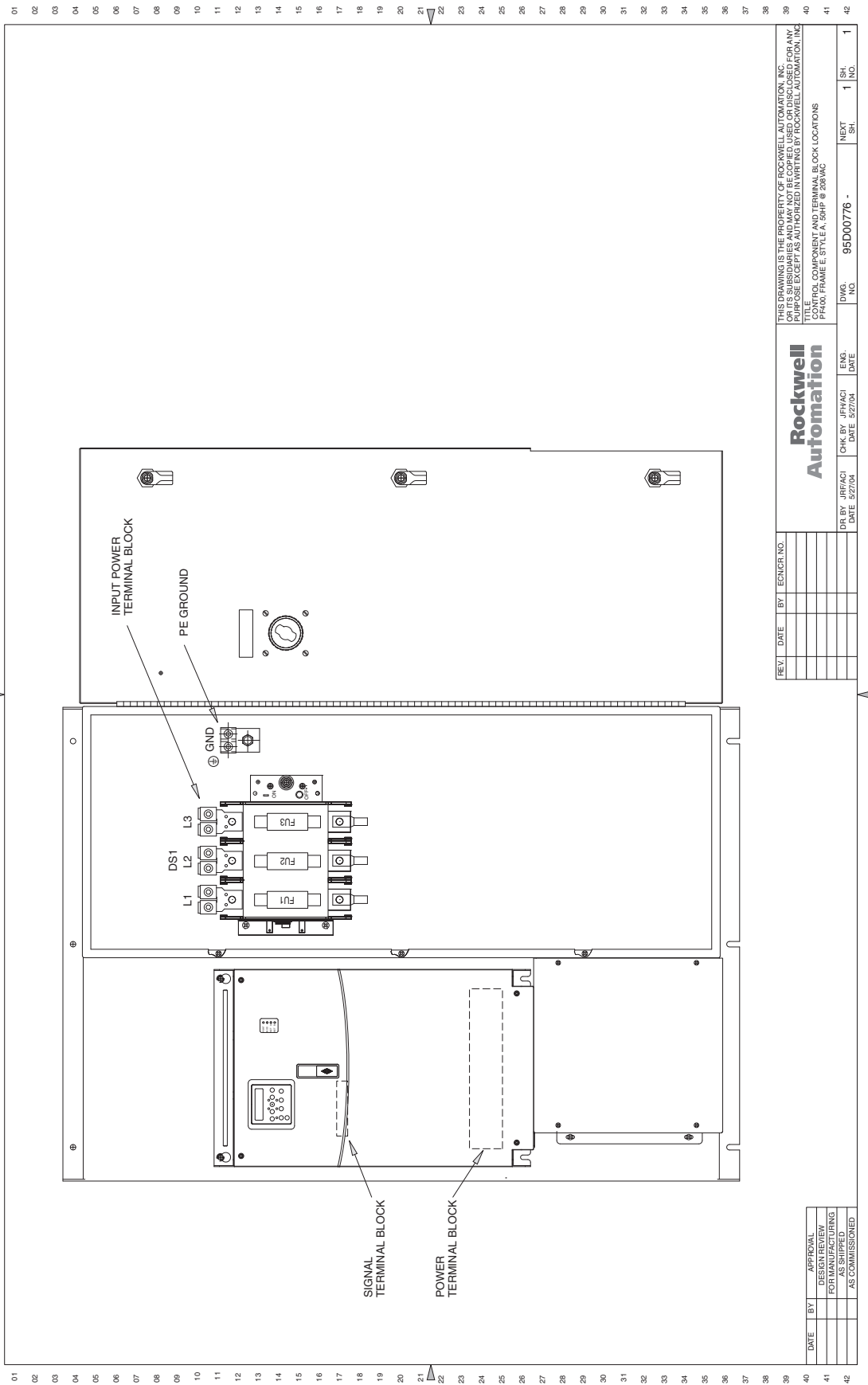

Figure 18 - 125...150 Hp, 460V AC Drives - NEMA/UL Type 1

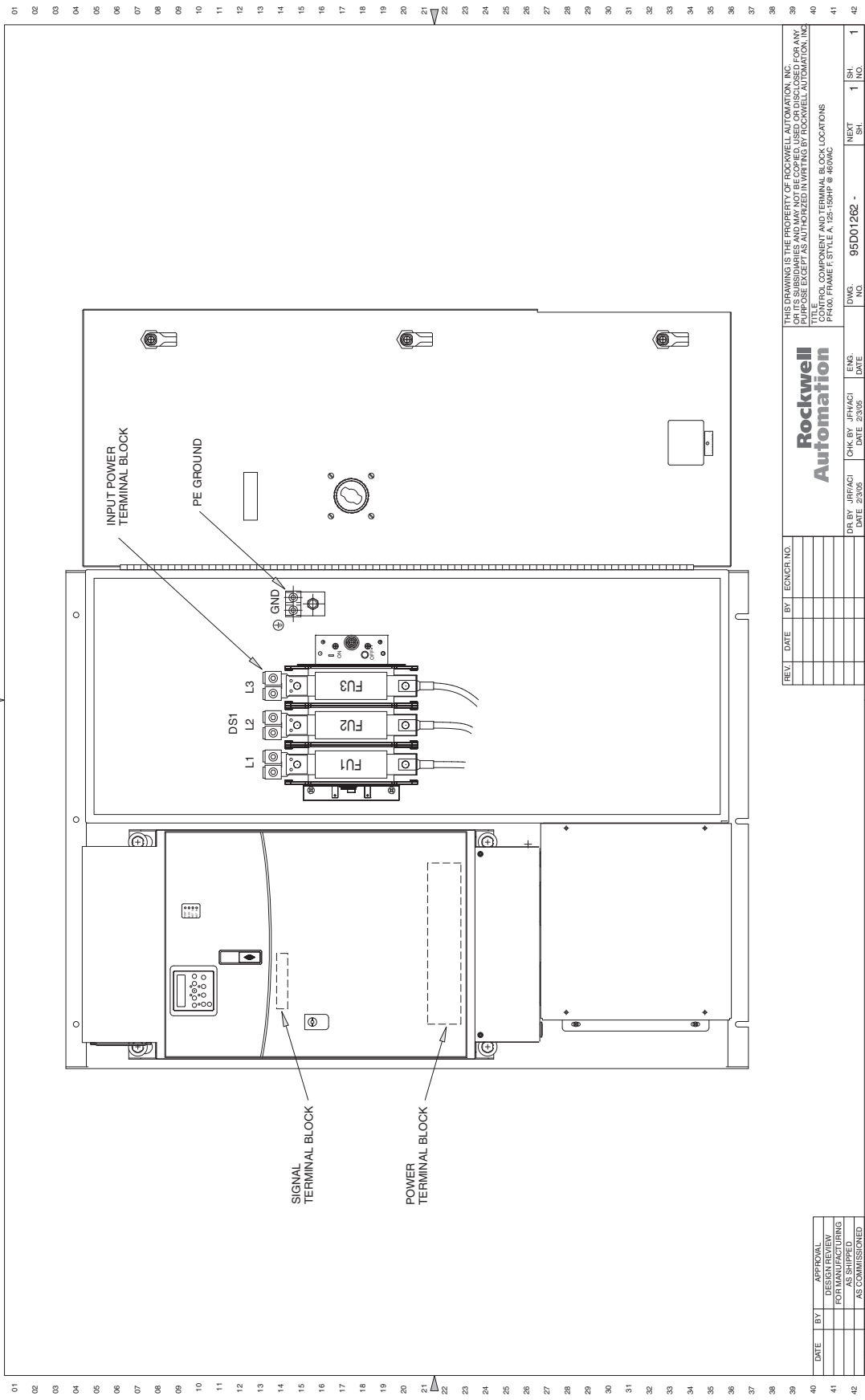

Figure 19 - 200...250 Hp, 460V AC Drives - NEMA/UL Type 1

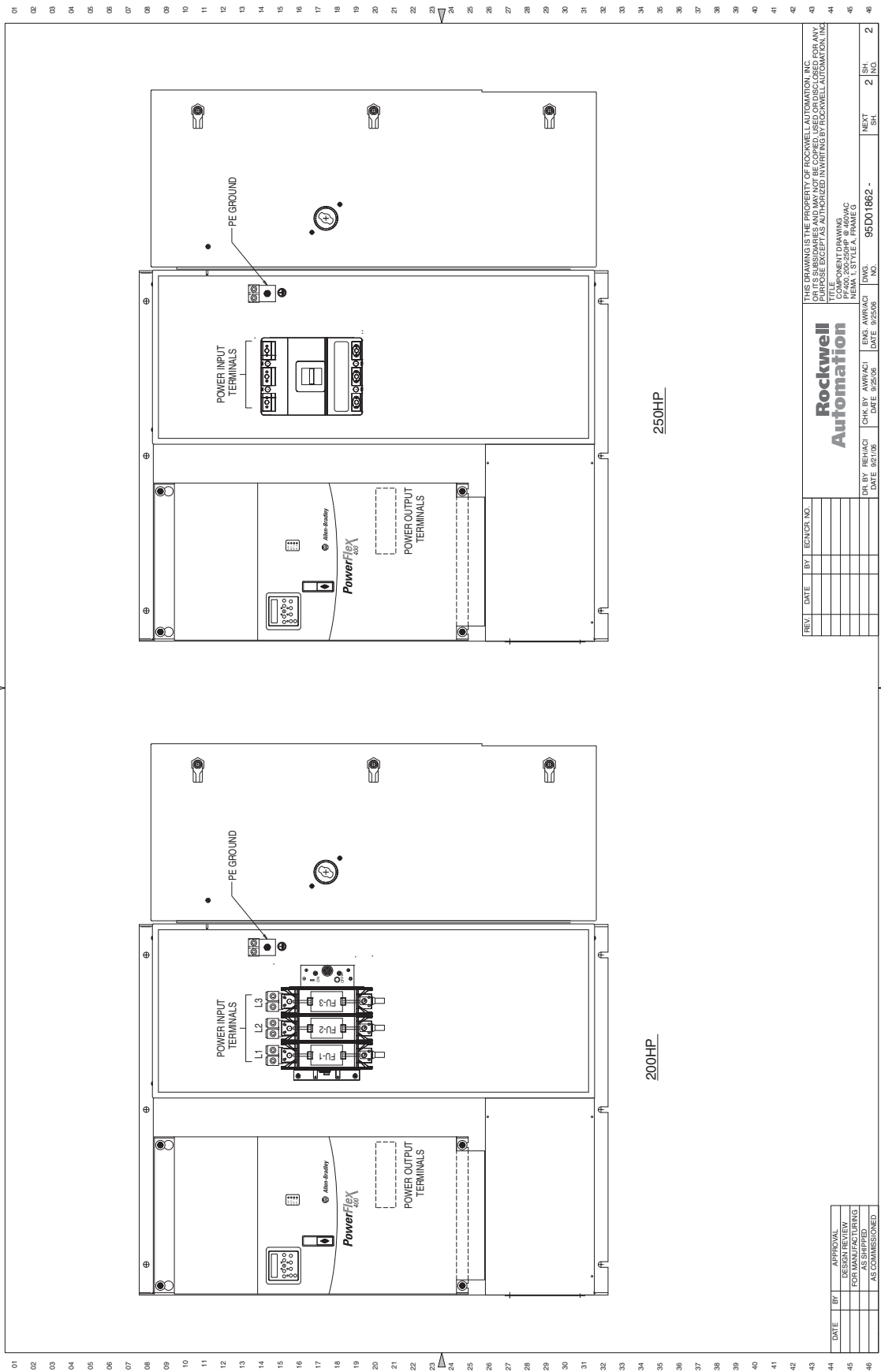
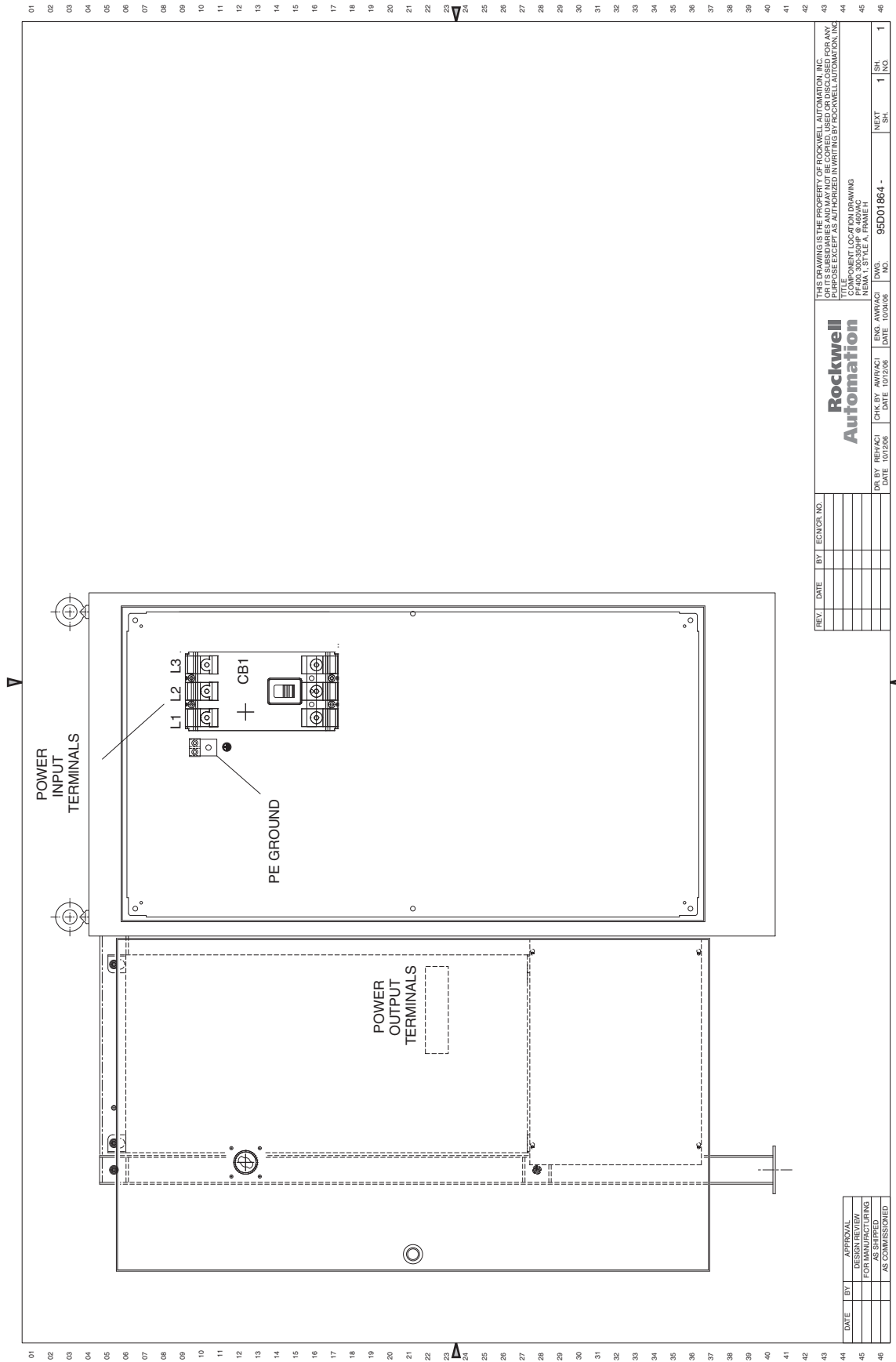

Figure 20 - 300...350 Hp, 460V AC Drives - NEMA/UL Type 1



THIS DRAWING IS THE PROPERTY OF ROCKWELL AUTOMATION, INC. OR ITS SUBSIDIARIES AND MAY NOT BE COPIED, USED OR DISCLOSED FOR ANY PURPOSE EXCEPT AS AUTHORIZED IN WRITING BY ROCKWELL AUTOMATION, INC.		
ROCKWELL AUTOMATION, INC. 2500 W. GARDEN AVENUE, GRAND RAPIDS, MI 49508		
COMPONENT LOCATION DRAWING		
NO.	DWG.	NO.
95D01864 -	100406	1
SH.	SH.	1
NO.	NO.	1
NO.	NO.	1

REV.	DATE	BY	EDISON NO.	

CHK BY	AMR/ACI	ENG.	AMR/ACI
DATE	10/12/06	DATE	10/12/06

DR BY	REH/ACI	DATE	10/12/06
-------	---------	------	----------

APPROVAL	FOR MANUFACTURING	AS SHIPPED	AS COMMISSIONED

Figure 21 - 3.0...5.0 Hp, 208V AC and 3.0...10 Hp, 460V AC Drives with Line Reactor - NEMA/UL Type 1

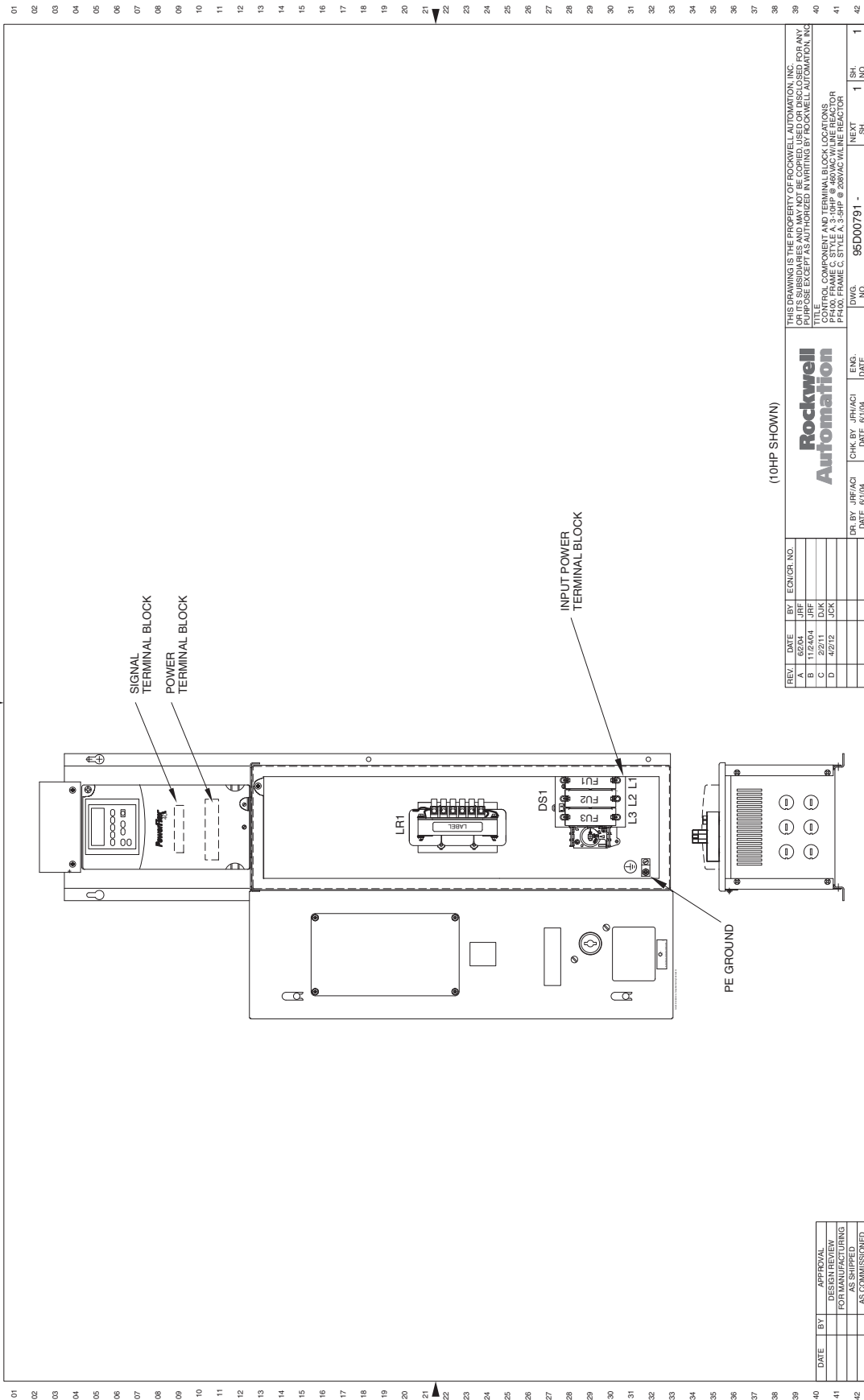

Figure 22 - 7.5...10 Hp, 208V AC and 15...20 Hp, 460V AC Drives with Line Reactor - NEMA/UL Type 1

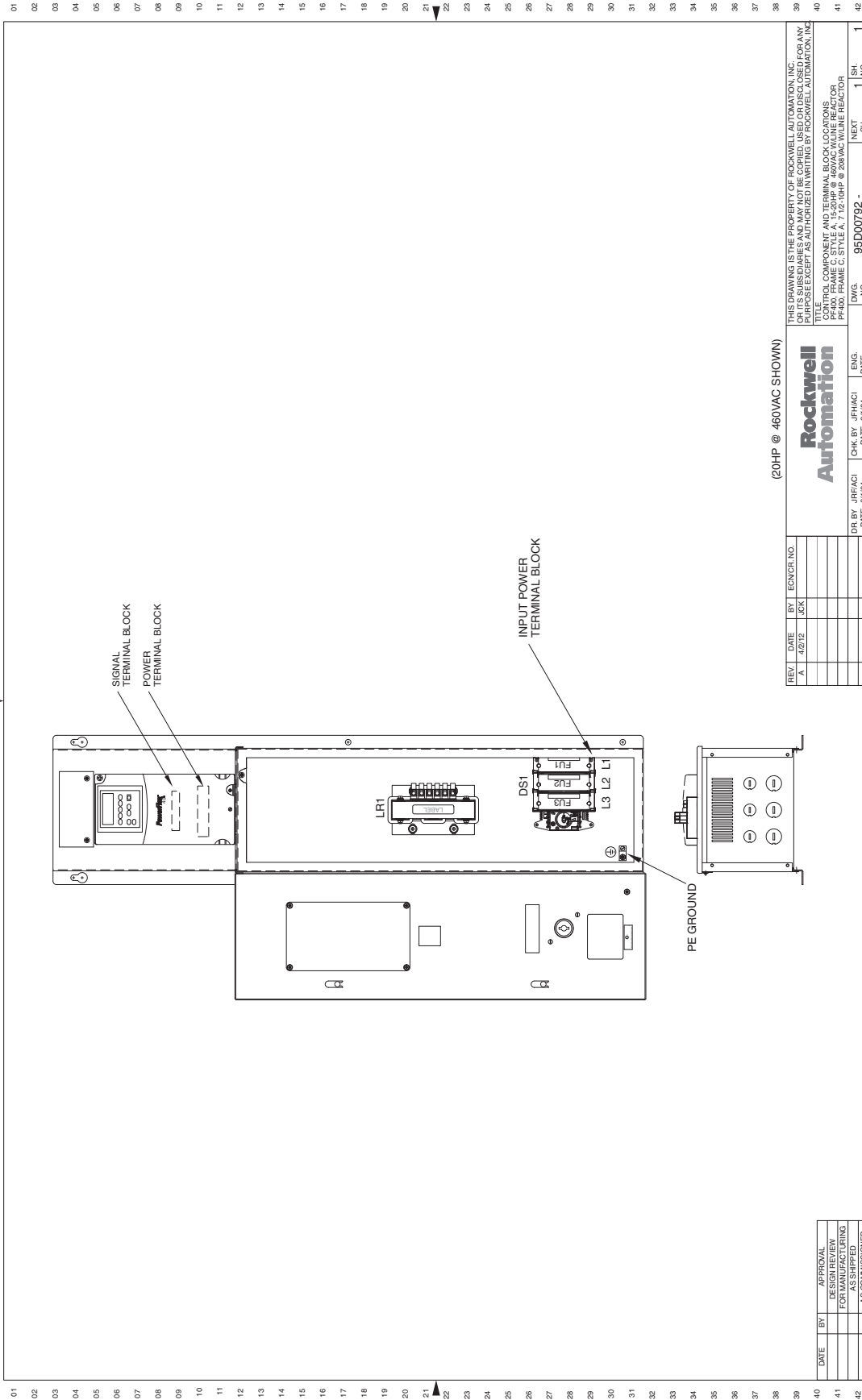

Figure 23 - 15...20 Hp, 208V AC and 25...40 Hp, 460V AC Drives with Line Reactor - NEMA/UL Type 1

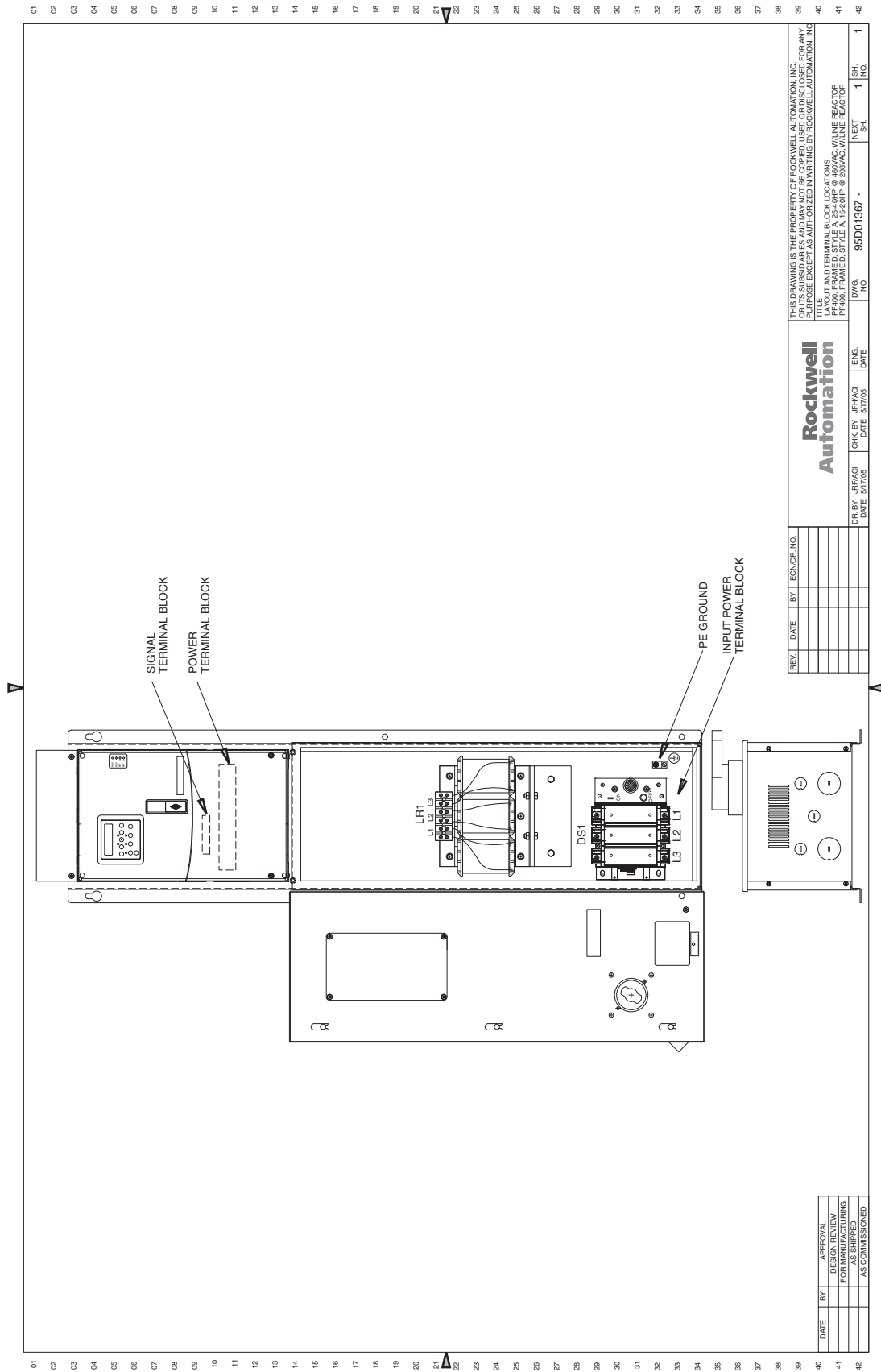

Figure 24 - 25...30 Hp, 208V AC Drives with Line Reactor - NEMA/UL Type 1

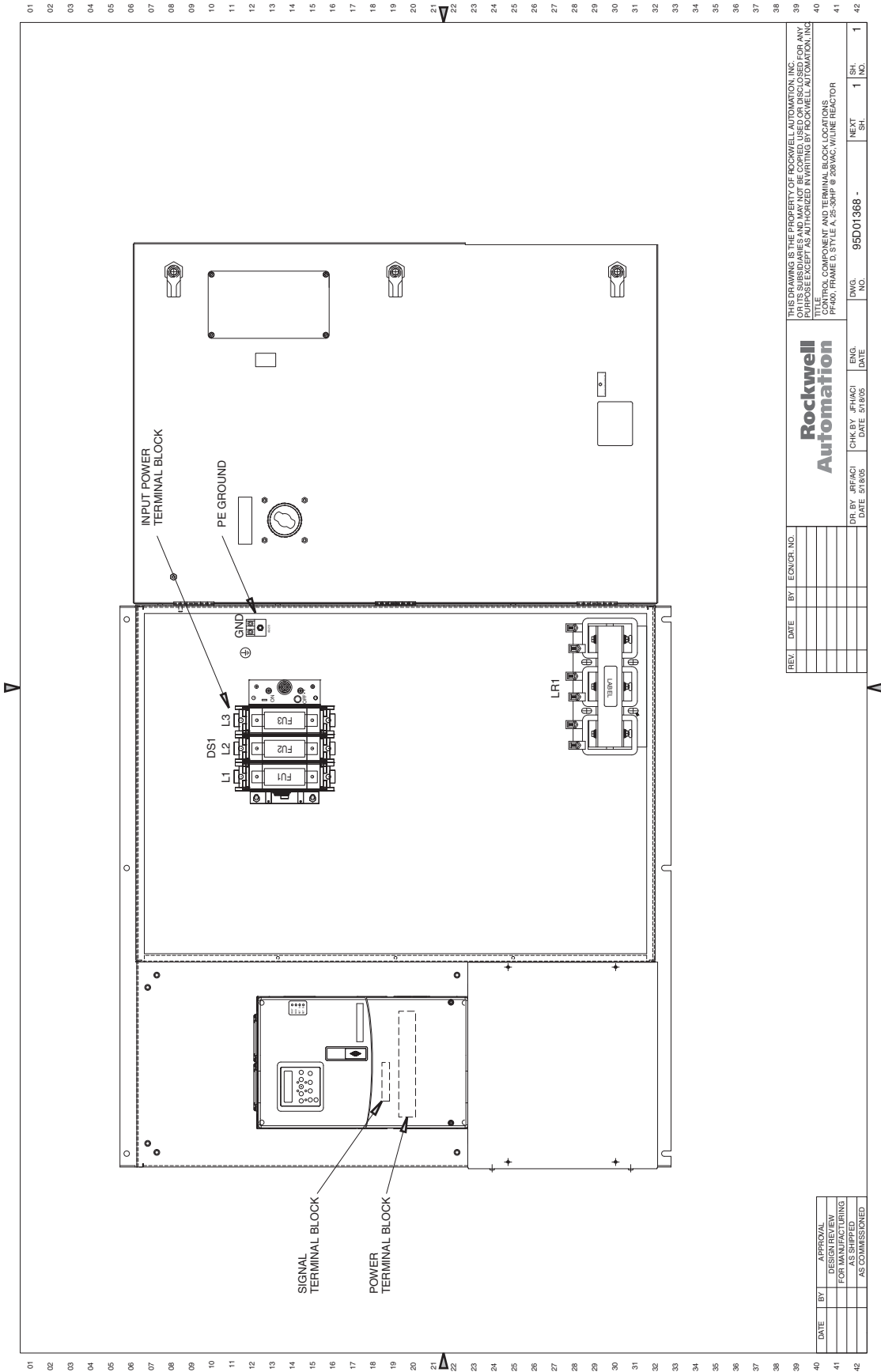
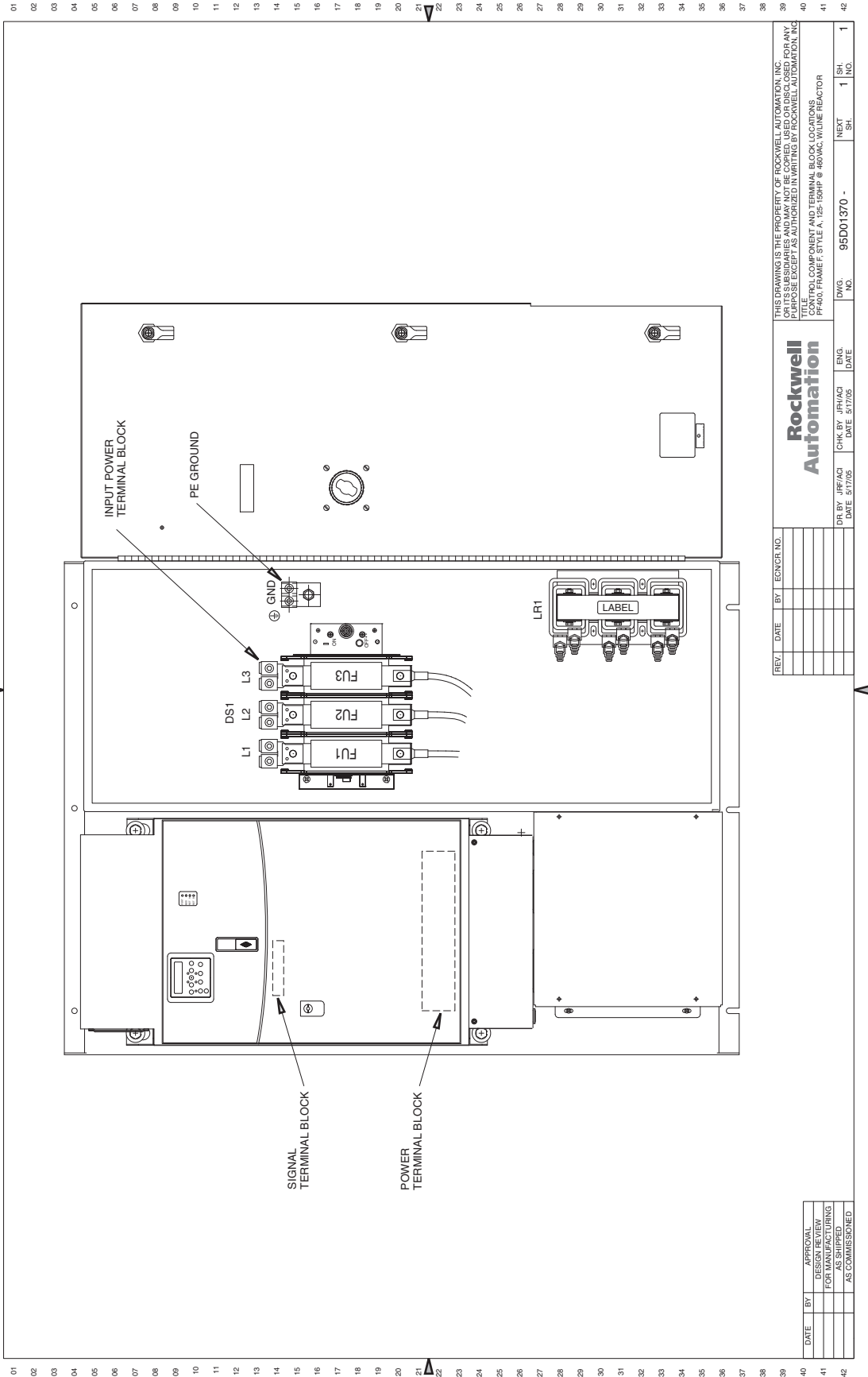

Figure 26 - 125...150 Hp, 460V AC Drives with Line Reactor - NEMA/UL Type 1



REV.	DATE	BY	ECNCR NO.	DR BY	JRH/ACI	DATE	5/17/06	CHK BY	JRH/ACI	DATE	5/17/06	ENG.	NO.	DWG.	95D01370 -	NO.	NEXT	SH.	1	SH.	1	INC.	1

THIS DRAWING IS THE PROPERTY OF ROCKWELL AUTOMATION, INC. OR ITS SUBSIDIARIES AND MAY NOT BE COPIED, REPRODUCED, OR DISCLOSED FOR ANY PURPOSES EXCEPT AS AUTHORIZED IN WRITING BY ROCKWELL AUTOMATION, INC.

TITLE
CONTROL COMPONENT AND TERMINAL BLOCK LOCATIONS
(7-148) (FRAME STYLE A, 125-150HP @ 460VAC) WITH LINE REACTOR

DATE	BY	APPROVAL
		DESIGN REVIEW FOR MANUFACTURING AS SHIPPED
		AS COMMISSIONED

Figure 27 - 3.0...10 Hp, 208V and 3.0...20 Hp, 460V AC Drives - NEMA/UL Type 12

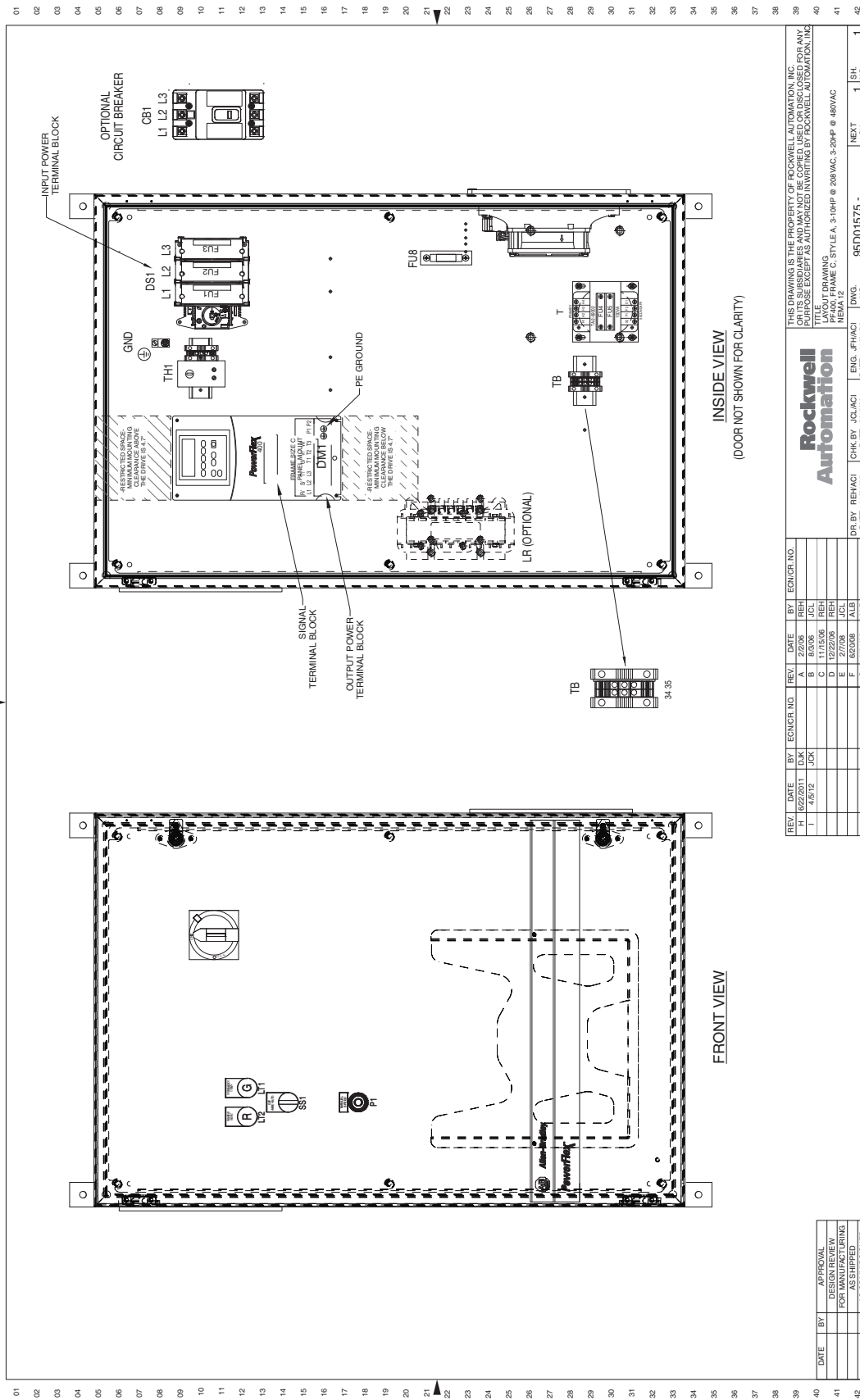

Figure 28 - 15...20 Hp, 208V AC and 25...40 Hp 460V AC Drives - NEMA/UL Type 12

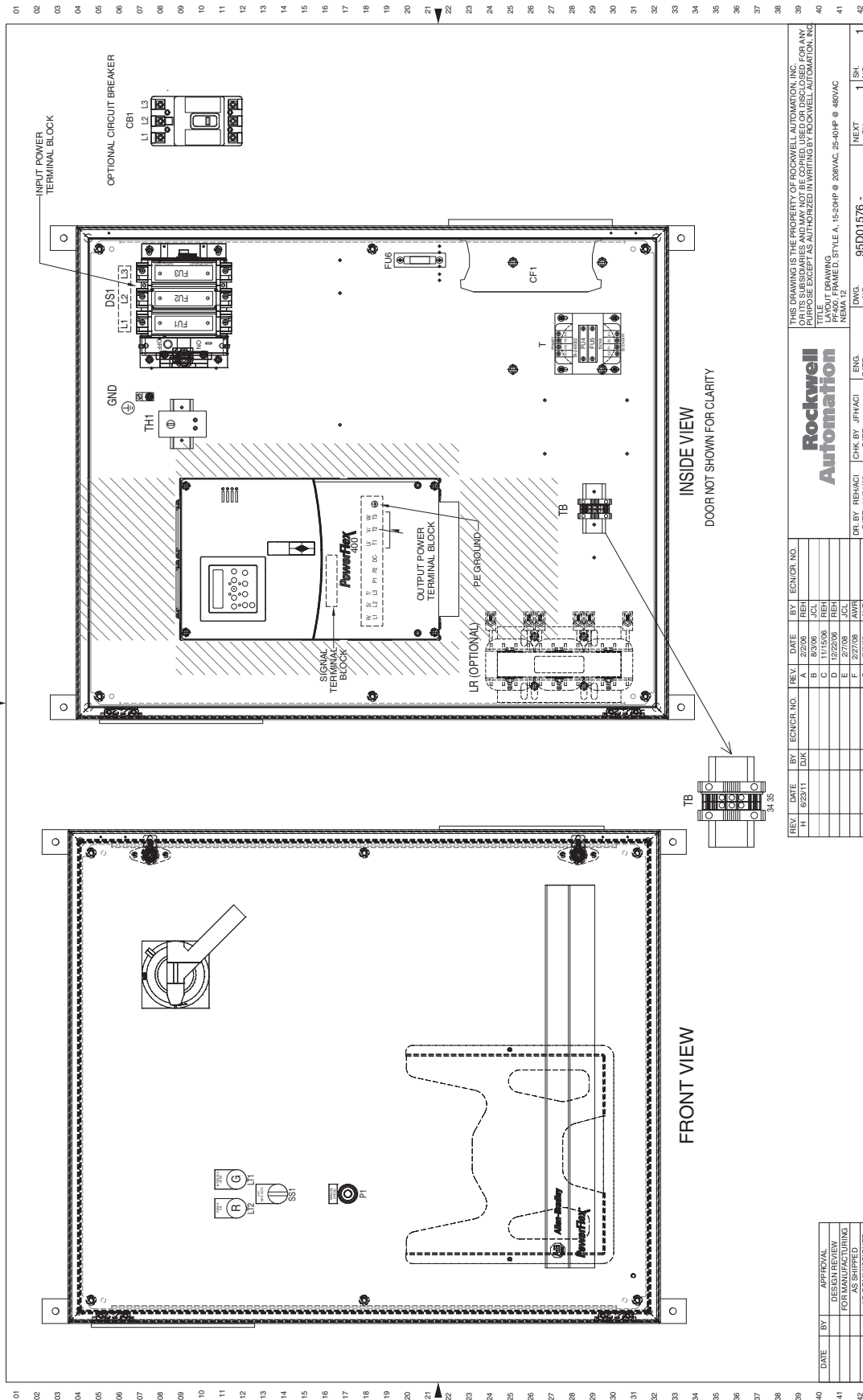
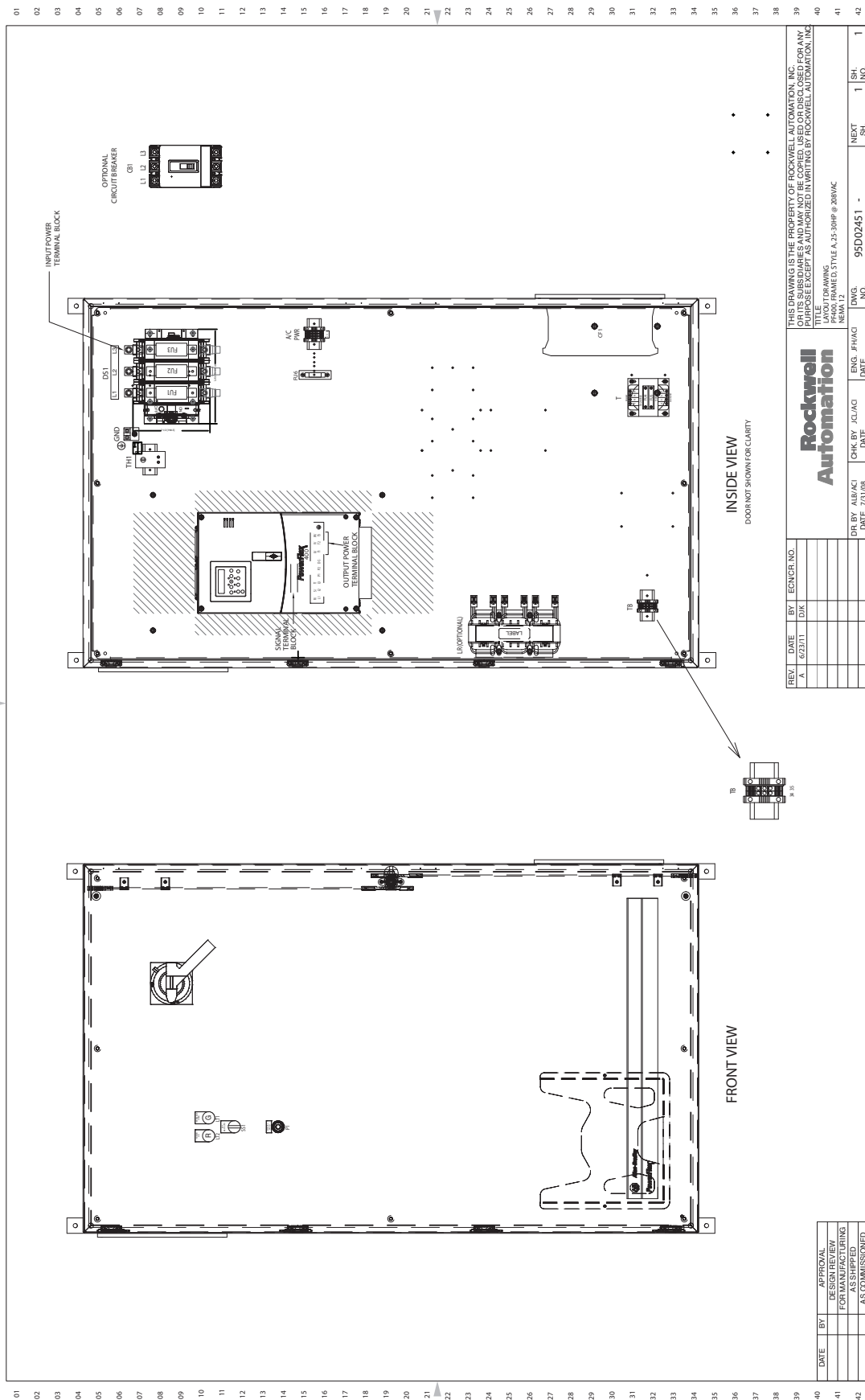

Figure 29 - 25...30 Hp, 208V AC Drives - NEMA/UL Type 12



REV.	DATE	BY	ECN/CR. NO.
A	6/22/11	DK	
<p>THIS DRAWING IS THE PROPERTY OF ROCKWELL AUTOMATION, INC. FOR ANY REUSE OR REPRODUCTION WITHOUT THE WRITTEN PERMISSION OF ROCKWELL AUTOMATION, INC. THIS DRAWING IS NOT TO BE USED FOR ANY PURPOSE EXCEPT AS AUTHORIZED IN WRITING BY ROCKWELL AUTOMATION, INC.</p>			
<p>TITLE FOR DRAWING: P4400, FRAMED, STYLE A, 25-30HP @ 208VAC</p>			
DR. BY	ALB/ACT	CHK. BY	JG/LAG
DATE	7/2/08	DATE	
ENG. #/PAC		DWG. NO.	95D02451 -
		DATE	
		1 SH.	1
		1 SH.	1

DATE	BY	APPROVAL
		DESIGN REVIEW
		FOR MANUFACTURING
		AS SHIPPED
		AS COMMISSIONED

Figure 30 - 40...50 Hp, 208V AC Drives - NEMA/UL Type 12

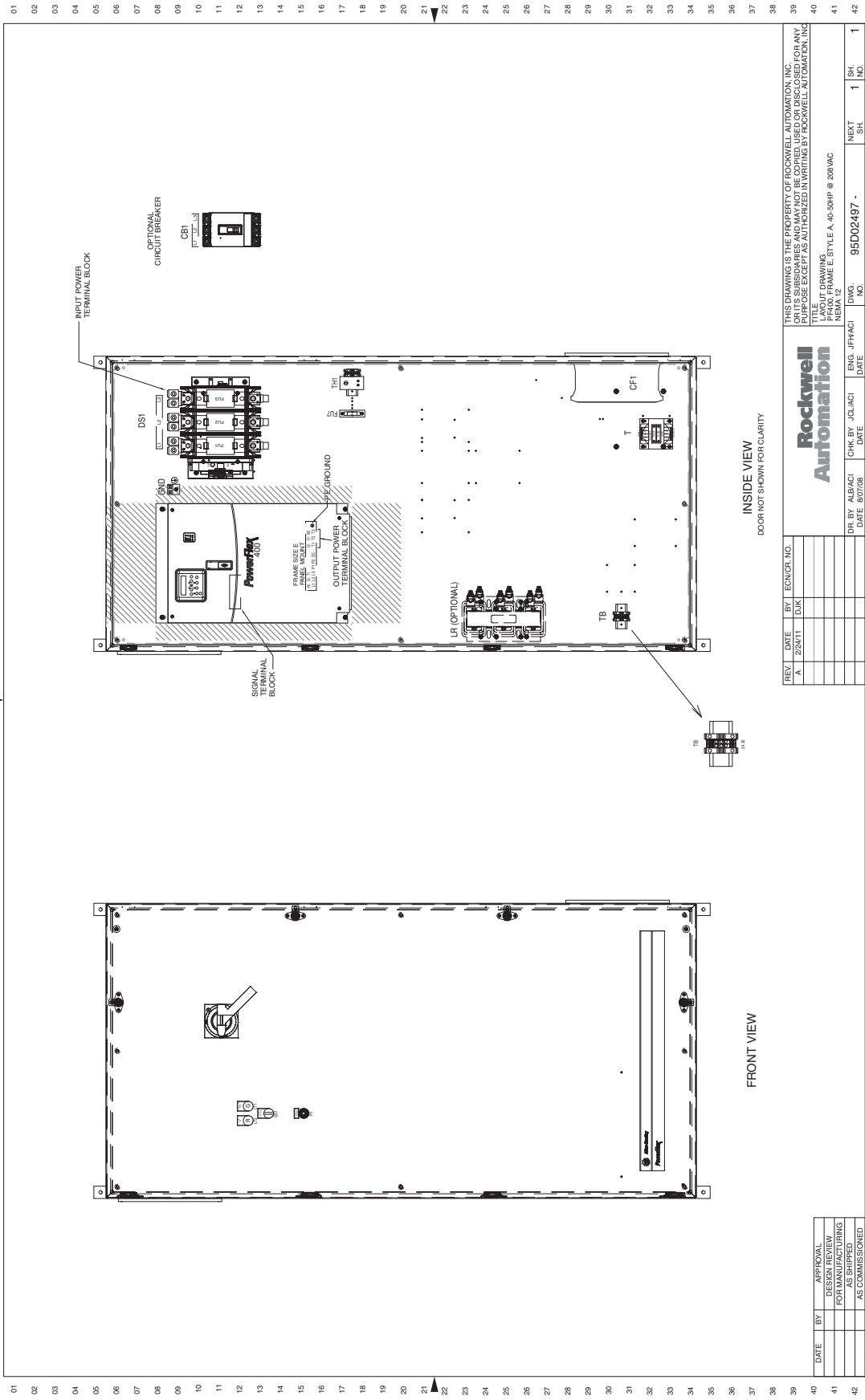

REV. A	DATE 2/24/11	BY DJK	ECNOR. NO.	THIS DRAWING IS THE PROPERTY OF ROCKWELL AUTOMATION, INC. OR ITS SUBSIDIARIES AND MAY NOT BE COPIED, USED OR DISCLOSED FOR ANY PURPOSES EXCEPT AS AUTHORIZED IN WRITING BY ROCKWELL AUTOMATION, INC.
				TITLE LAYOUT DRAWING
				DR. BY ALB/ACI DATE 8/07/08
				ENG. JFH/ACI DATE
				DWG. NO. 95D02497 -
				NEXT SH. 1
				SH. NO. 1

Figure 31 - 50...60 Hp, 460V AC Drives - NEMA/UL Type 12

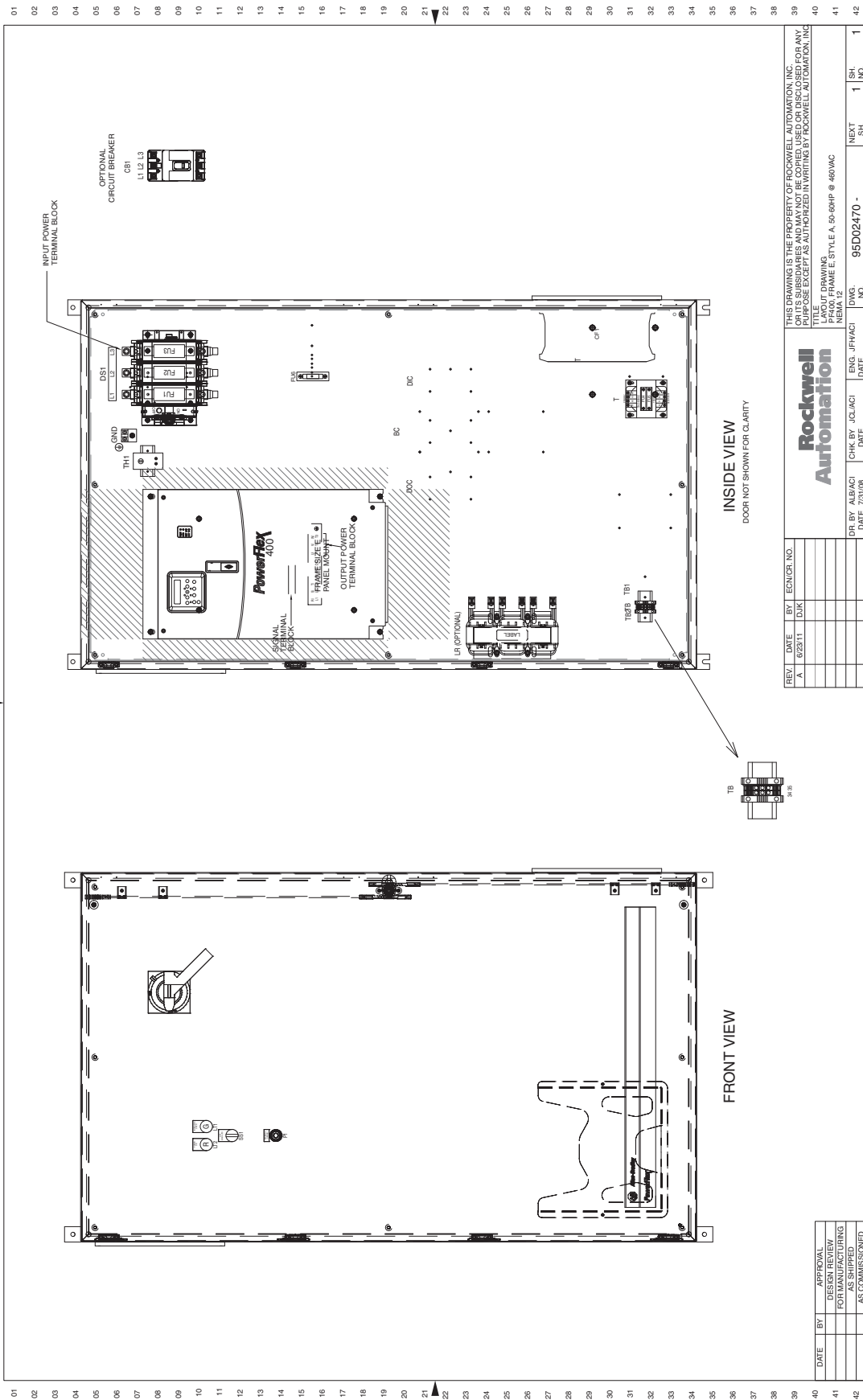
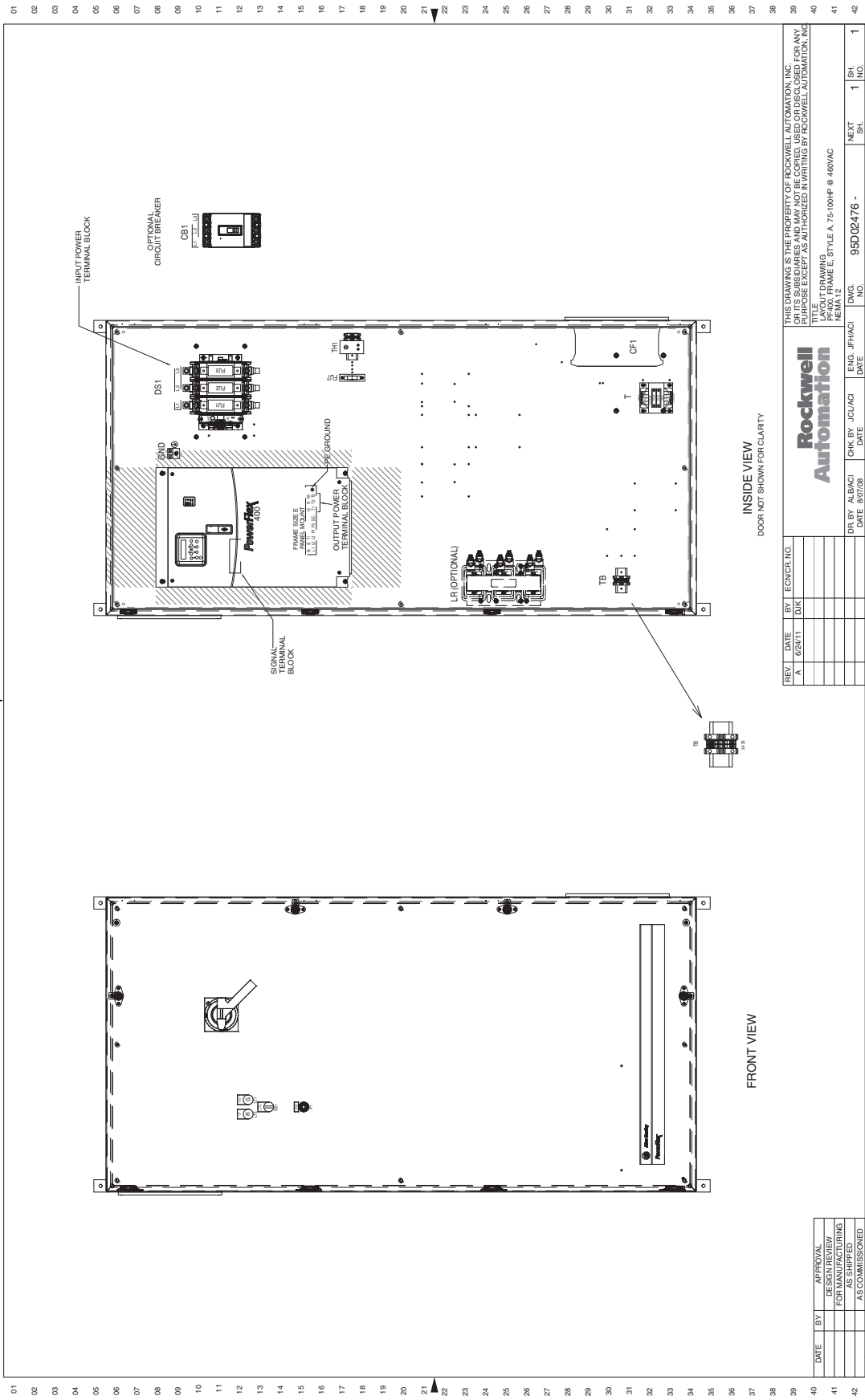

Figure 32 - 75...100 Hp, 460V AC Drives - NEMA/UL Type 12



01	02	03	04	05	06	07	08	09	10	11	12	13	14	15	16	17	18	19	20	21	22	23	24	25	26	27	28	29	30	31	32	33	34	35	36	37	38	39	40	41	42
REV.		DATE	BY	ECONCR. NO.	THIS DRAWING IS THE PROPERTY OF ROCKWELL AUTOMATION, INC. OR ITS SUBSIDIARIES AND MAY NOT BE COPIED, USED OR DISCLOSED FOR ANY PURPOSES EXCEPT AS AUTHORIZED BY ROCKWELL AUTOMATION, INC.		Rockwell Automation		LAYOUT DRAWING		FRAME E1, STYLE A, 75-100HP @ 460VAC		DWG. NO.		95D02476 -		NEXT SH.		1		SH. NO.		1		NO.		1		NO.		1		NO.		1						
A	8/24/11	DIK			DR. BY: ALBACI		CHK. BY: JCL/ACI		ENG. JFH/ACI		DATE		DATE		DATE		DATE		DATE		DATE		DATE		DATE		DATE		DATE		DATE		DATE		DATE						
DATE		BY		APPROVAL		DESIGN REVIEW		FOR MANUFACTURING		AS SHIPPED		AS COMMISSIONED																													

Figure 33 - 125...150 Hp, 460V AC Drives - NEMA/UL Type 12

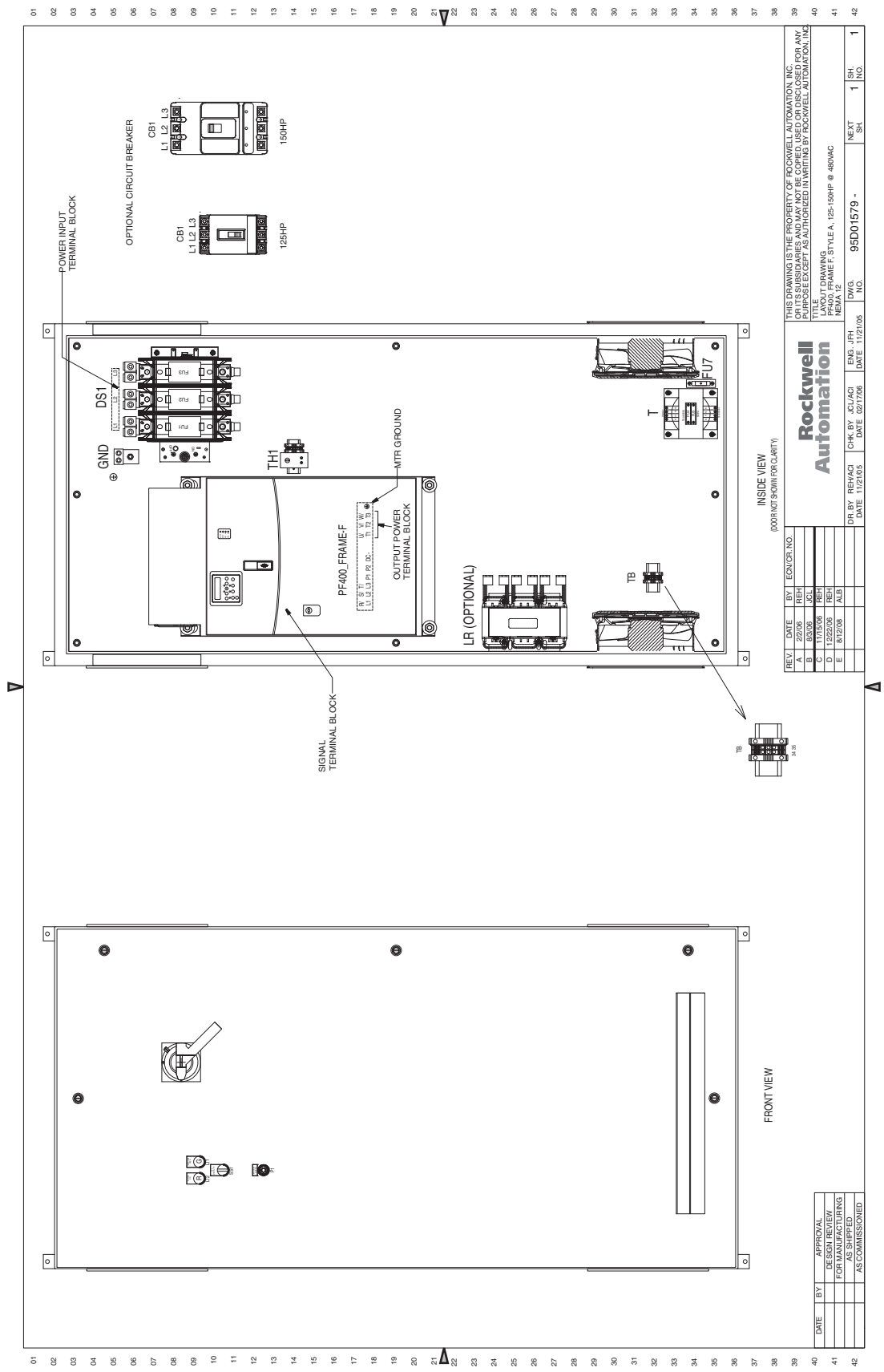

Figure 34 - 3.0...5.0 Hp, 460V AC Drives - NEMA/UL Type 4

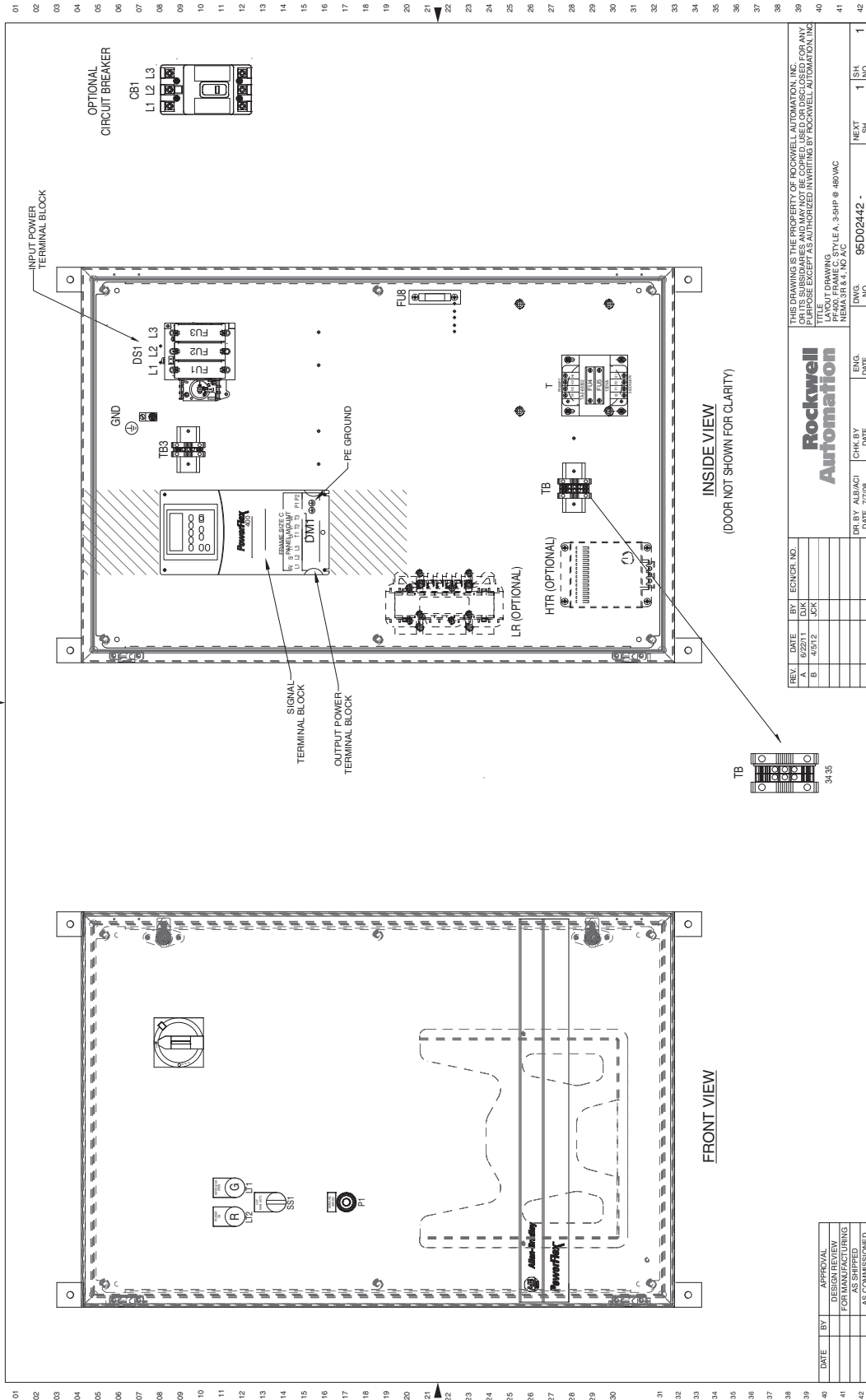

Figure 35 - 3.0...10 Hp, 208V AC and 7.5...20 Hp, 460V AC Drives - NEMA/UL Type 4

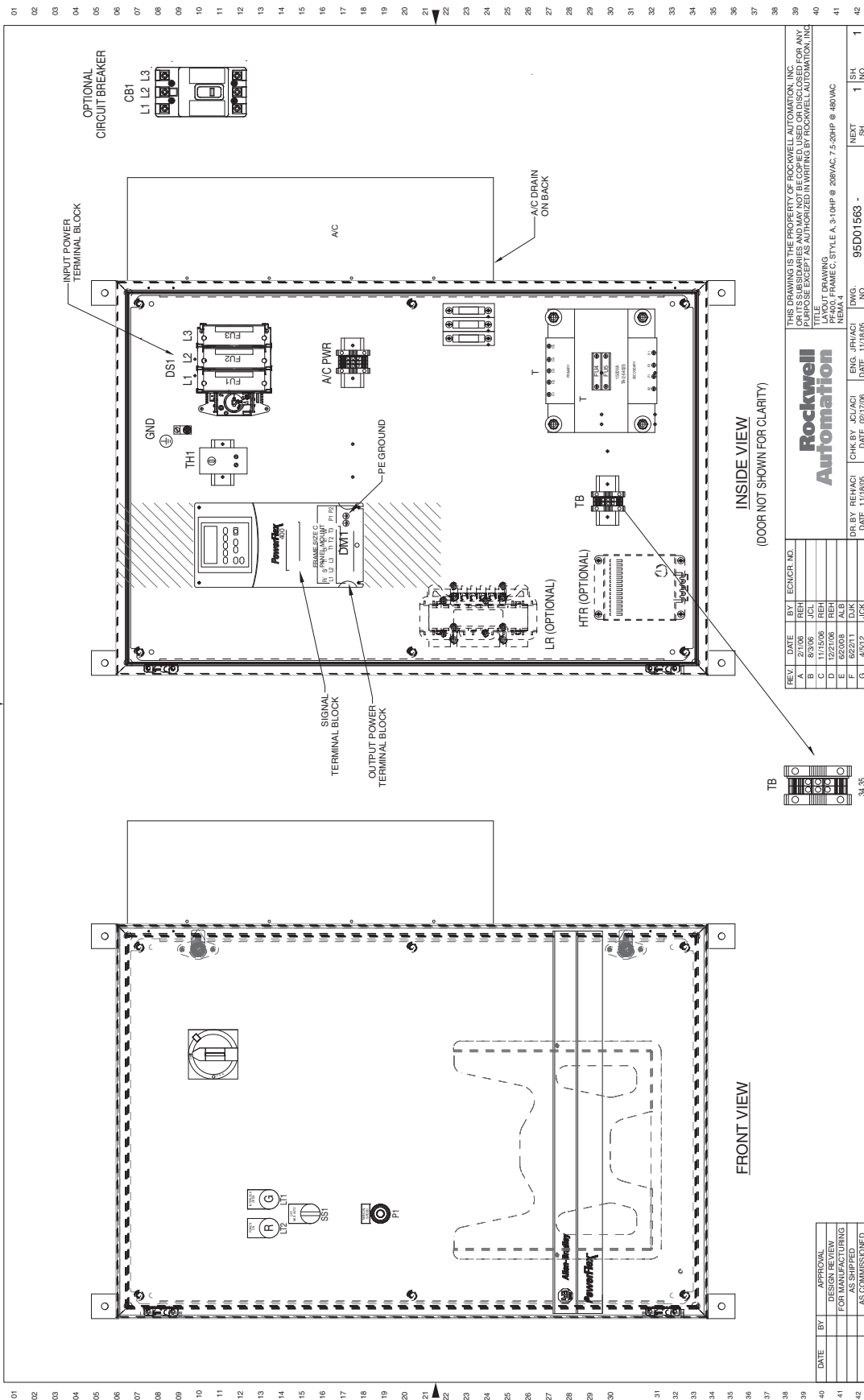

Figure 36 - 15...20 Hp, 208V AC and 25...40 Hp, 460V AC Drives - NEMA/UL Type 4

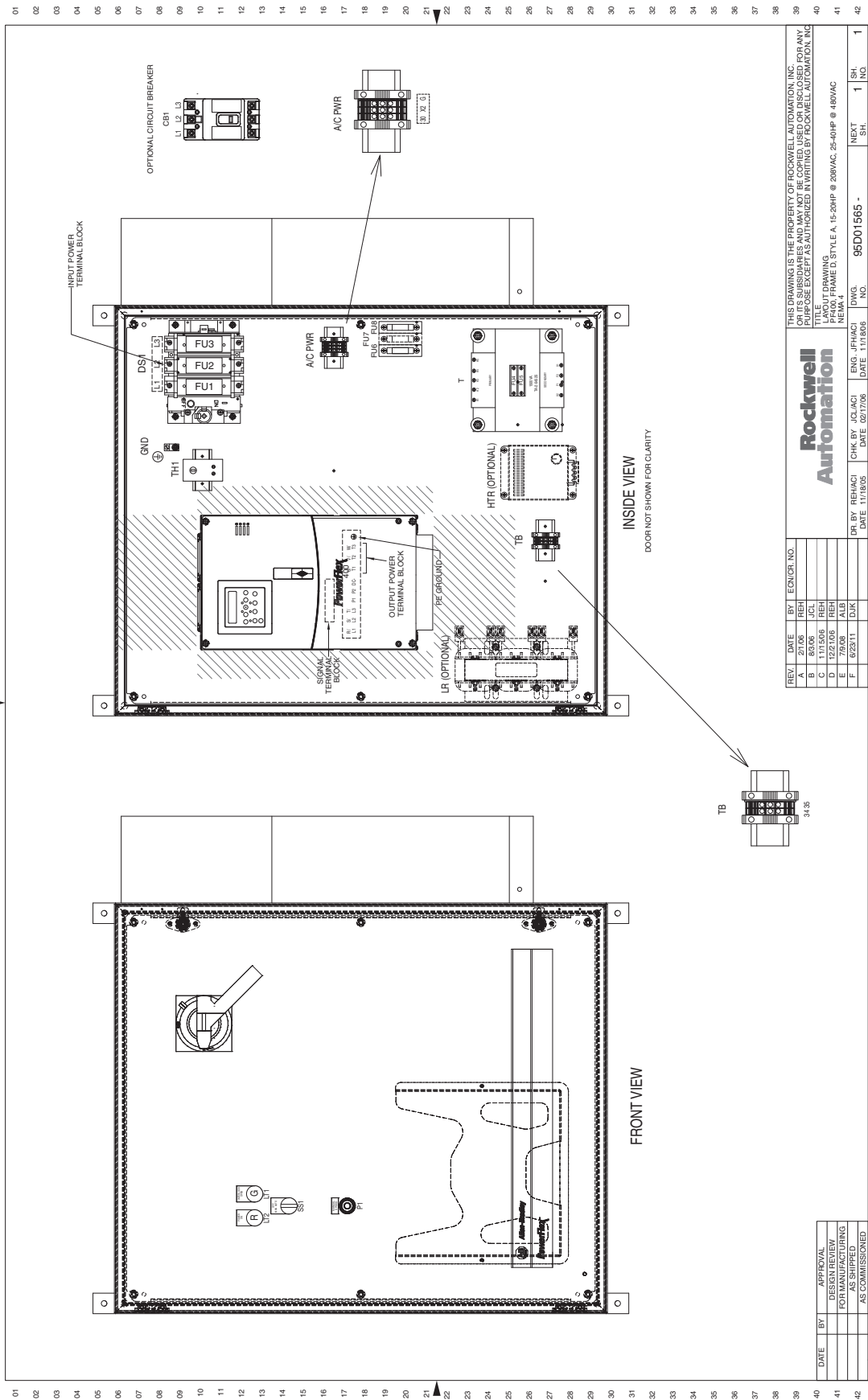

Figure 37 - 25...30 Hp, 208V AC Drives - NEMA/UL Type 4

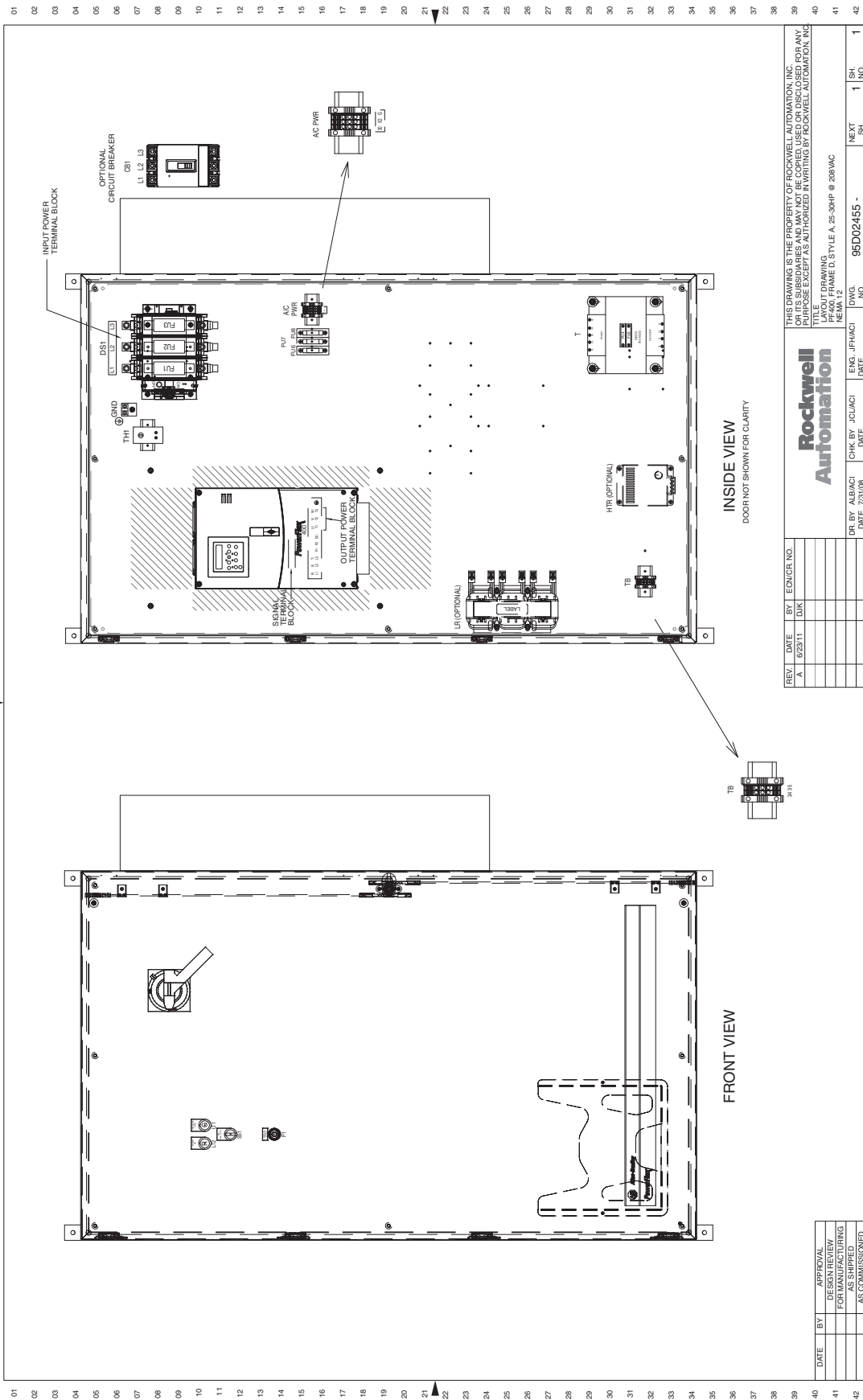
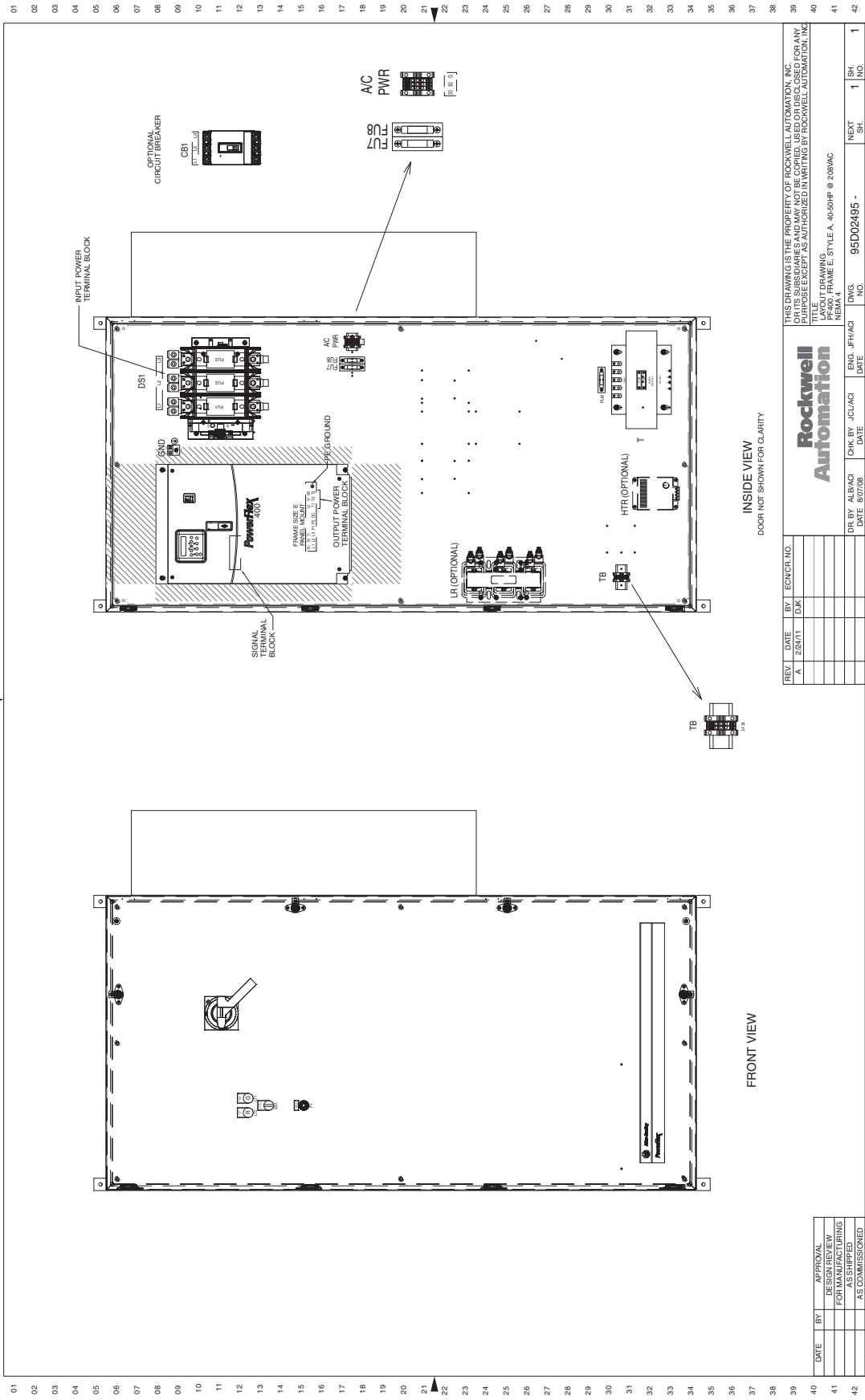

Figure 38 - 40...50 Hp, 208V AC Drives - NEMA/UL Type 4



REV	DATE	BY	ECN CR. NO.	DWG. NO.	ENG. JFH/ACI	DATE	DR. BY ALB/ACI	DATE	CHK. BY JQL/ACI	DATE	NO.	1	SH.	1	NO.	1
A	2/24/11	DJK		95D02495				8/07/08								
THIS DRAWING IS THE PROPERTY OF ROCKWELL AUTOMATION, INC. OR ITS SUBSIDIARIES AND MAY NOT BE COPIED, USED, OR DISCLOSED FOR ANY PURPOSES WITHOUT THE WRITTEN PERMISSION OF ROCKWELL AUTOMATION, INC.																
TITLE: LAYOUT DRAWING PART NAME: MAIN INPUT DISCONNECT PACKAGE (STYLE A, 40-50HP @ 208VAC)																
THIS DRAWING IS THE PROPERTY OF ROCKWELL AUTOMATION, INC. OR ITS SUBSIDIARIES AND MAY NOT BE COPIED, USED, OR DISCLOSED FOR ANY PURPOSES WITHOUT THE WRITTEN PERMISSION OF ROCKWELL AUTOMATION, INC.																

Figure 39 - 50...60 Hp, 460V AC Drives - NEMA/UL Type 4

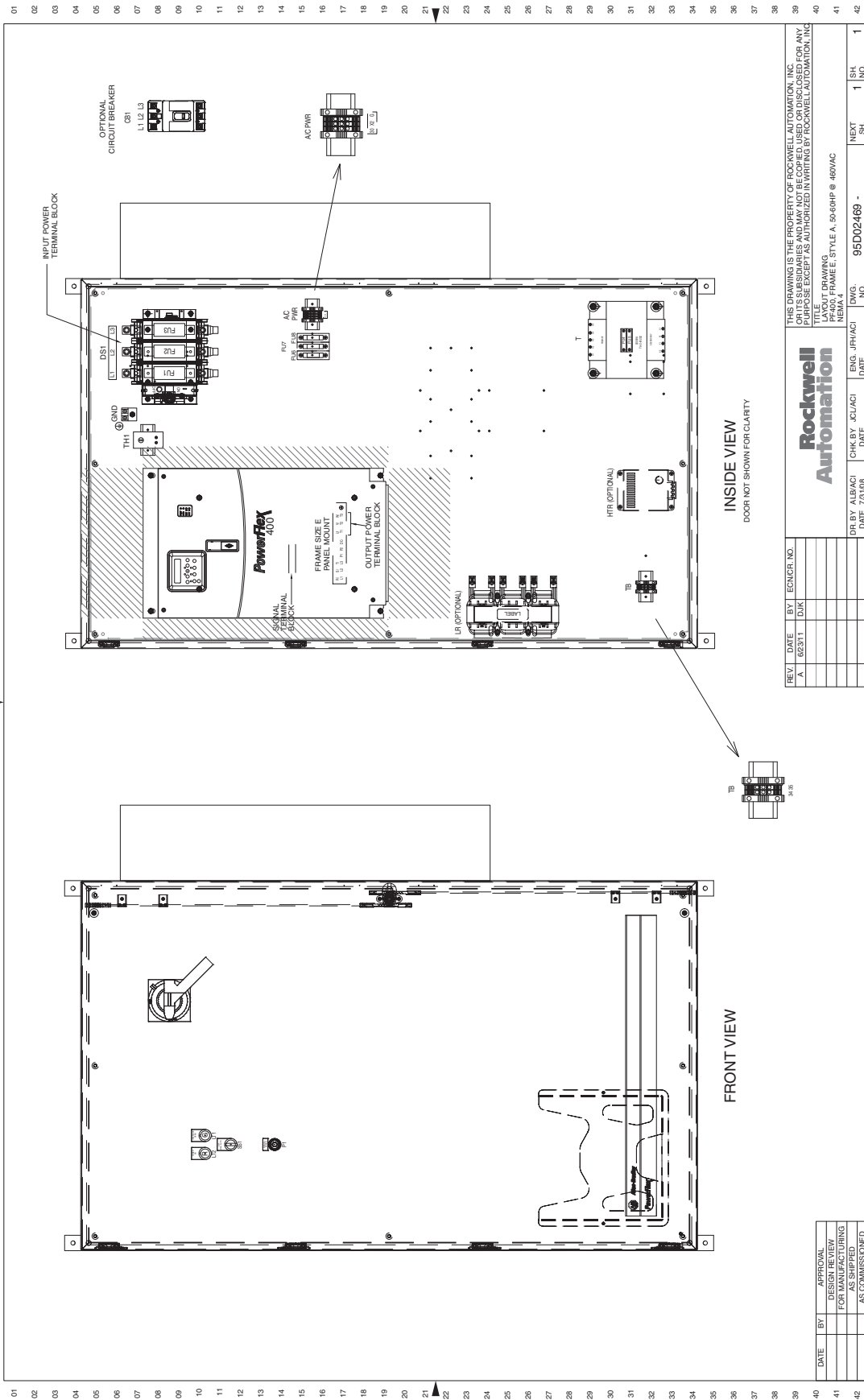
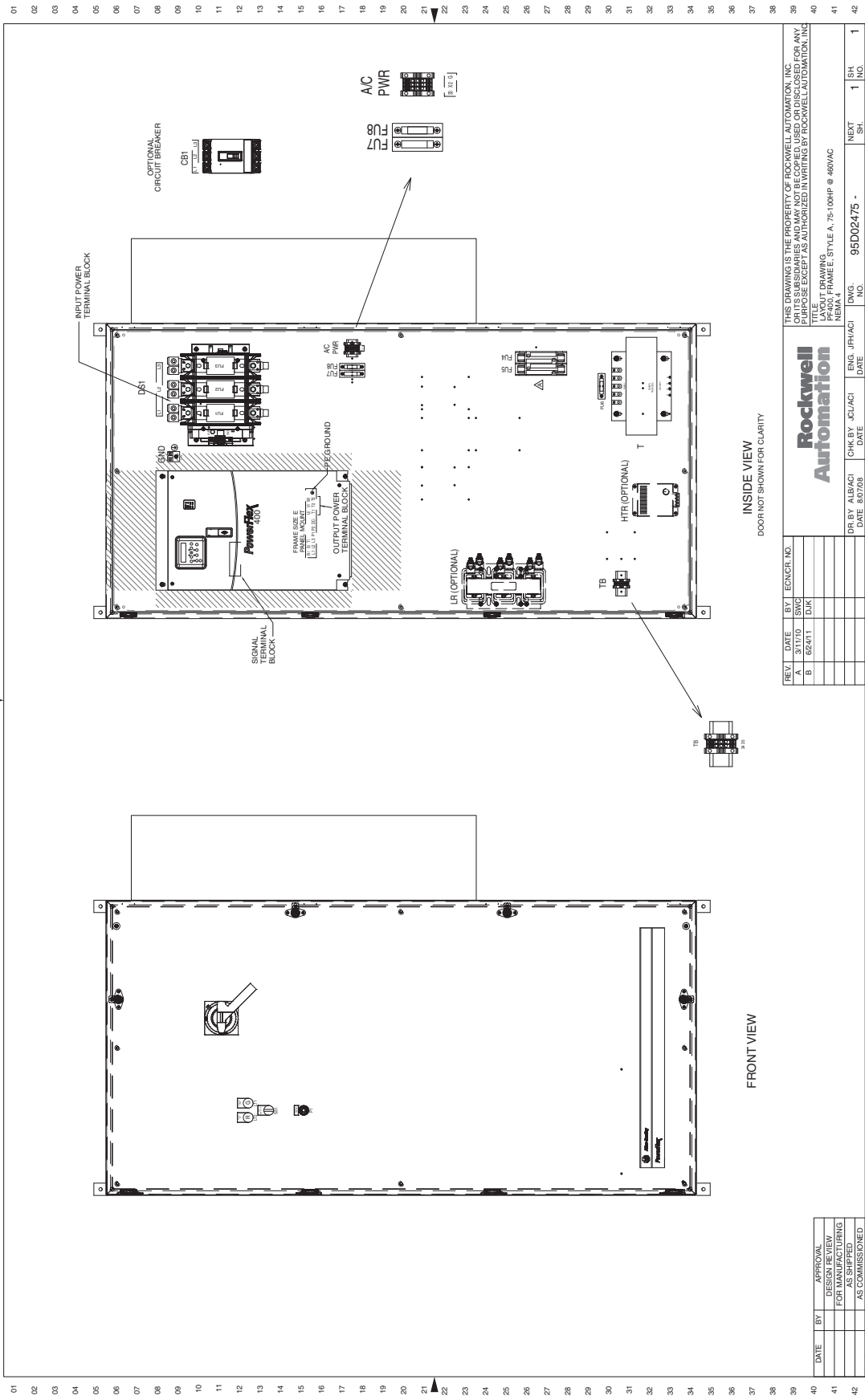

Figure 40 - 75...100 Hp, 460V AC Drives - NEMA/UL Type 4



01	02	03	04	05	06	07	08	09	10	11	12	13	14	15	16	17	18	19	20	21	22	23	24	25	26	27	28	29	30	31	32	33	34	35	36	37	38	39	40	41	42
REV		DATE	BY	ECNCR. NO.	THIS DRAWING IS THE PROPERTY OF ROCKWELL AUTOMATION, INC. OR ITS SUBSIDIARIES AND MAY NOT BE COPIED, USED, OR DISCLOSED FOR ANY PURPOSES WITHOUT THE WRITTEN PERMISSION OF ROCKWELL AUTOMATION, INC.		Rockwell Automation		TITL		LAYOUT DRAWING		FRAME STYLE A, 75-100HP @ 460VAC		DWG. NO.		95D02475		NEXT SH.		1		1		1		1		1		1		1		1		1				
A		3/11/10	SWC		LAYOUT DRAWING		Rockwell Automation		LAYOUT DRAWING		FRAME STYLE A, 75-100HP @ 460VAC		DWG. NO.		95D02475		NEXT SH.		1		1		1		1		1		1		1		1		1						
B		02/4/11	DJK		LAYOUT DRAWING		Rockwell Automation		LAYOUT DRAWING		FRAME STYLE A, 75-100HP @ 460VAC		DWG. NO.		95D02475		NEXT SH.		1		1		1		1		1		1		1		1		1						
DR. BY		ALB/ACI	DATE	8/07/08	CHK. BY		JL/ACI	DATE		ENG. JH/ACI		DATE		DWG. NO.		95D02475		NEXT SH.		1		1		1		1		1		1		1		1		1					
APPROVAL		DESIGN REVIEW		FOR MANUFACTURING		AS SHIPPED		AS COMMISSIONED																																	

Figure 41 - 125...150 Hp, 460V AC Drives - NEMA/UL Type 4

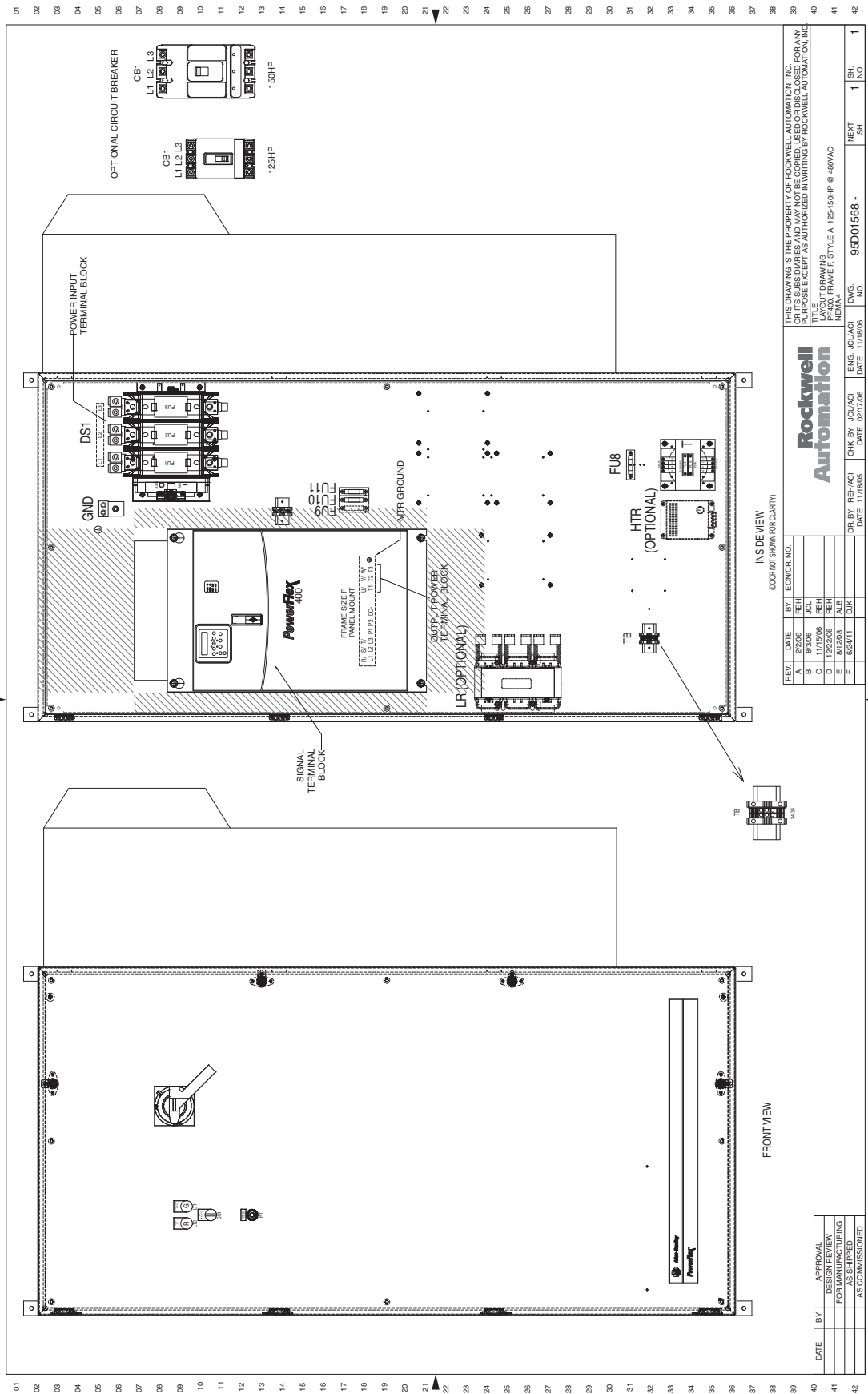

Figure 42 - 3.0...10 Hp, 208V AC and 3.0...20 Hp, 460V AC Drives - NEMA/UL Type 3R

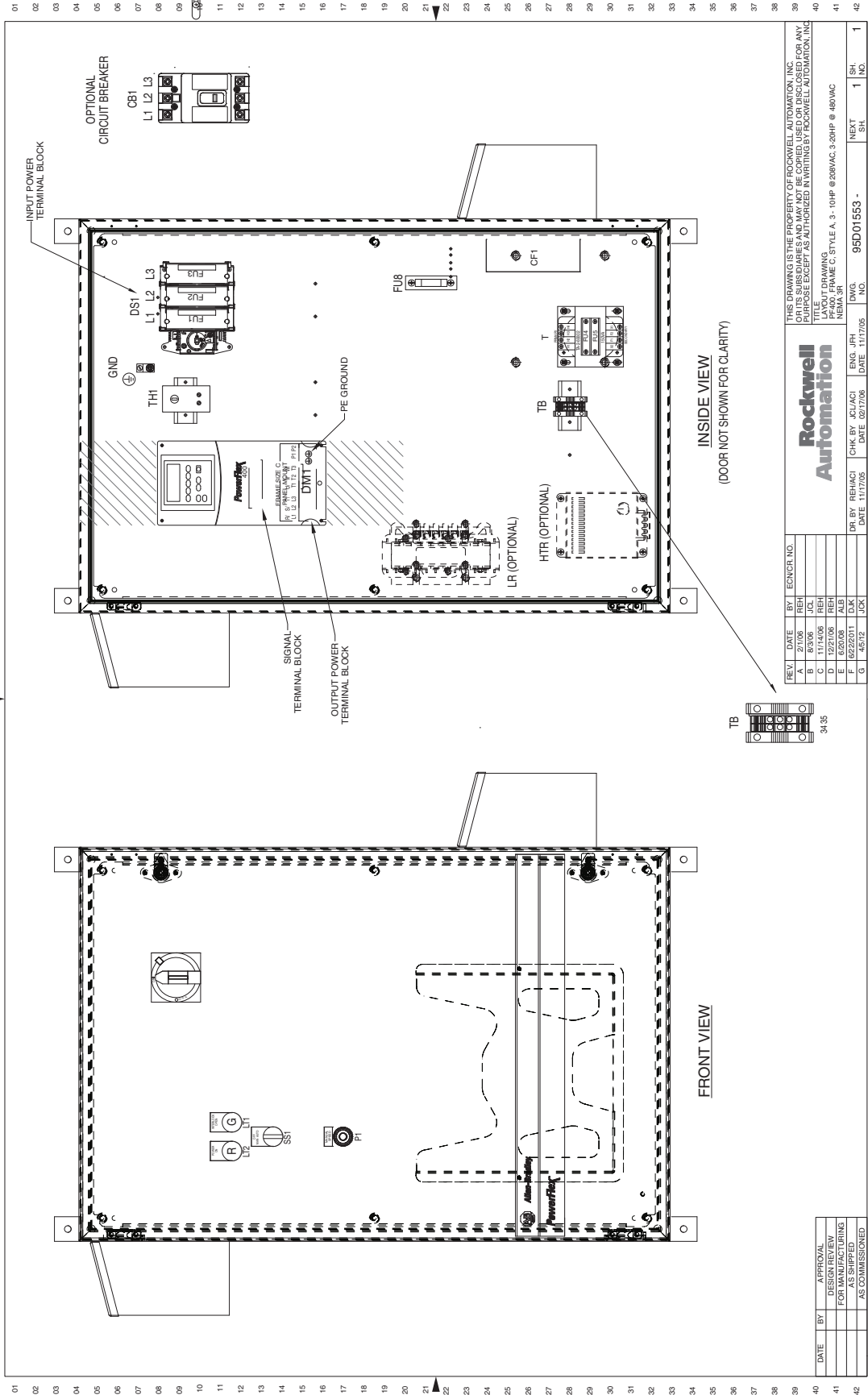

Figure 43 - 15...20 Hp, 208V AC and 25...40 Hp, 460V AC Drives - NEMA/UL Type 3R

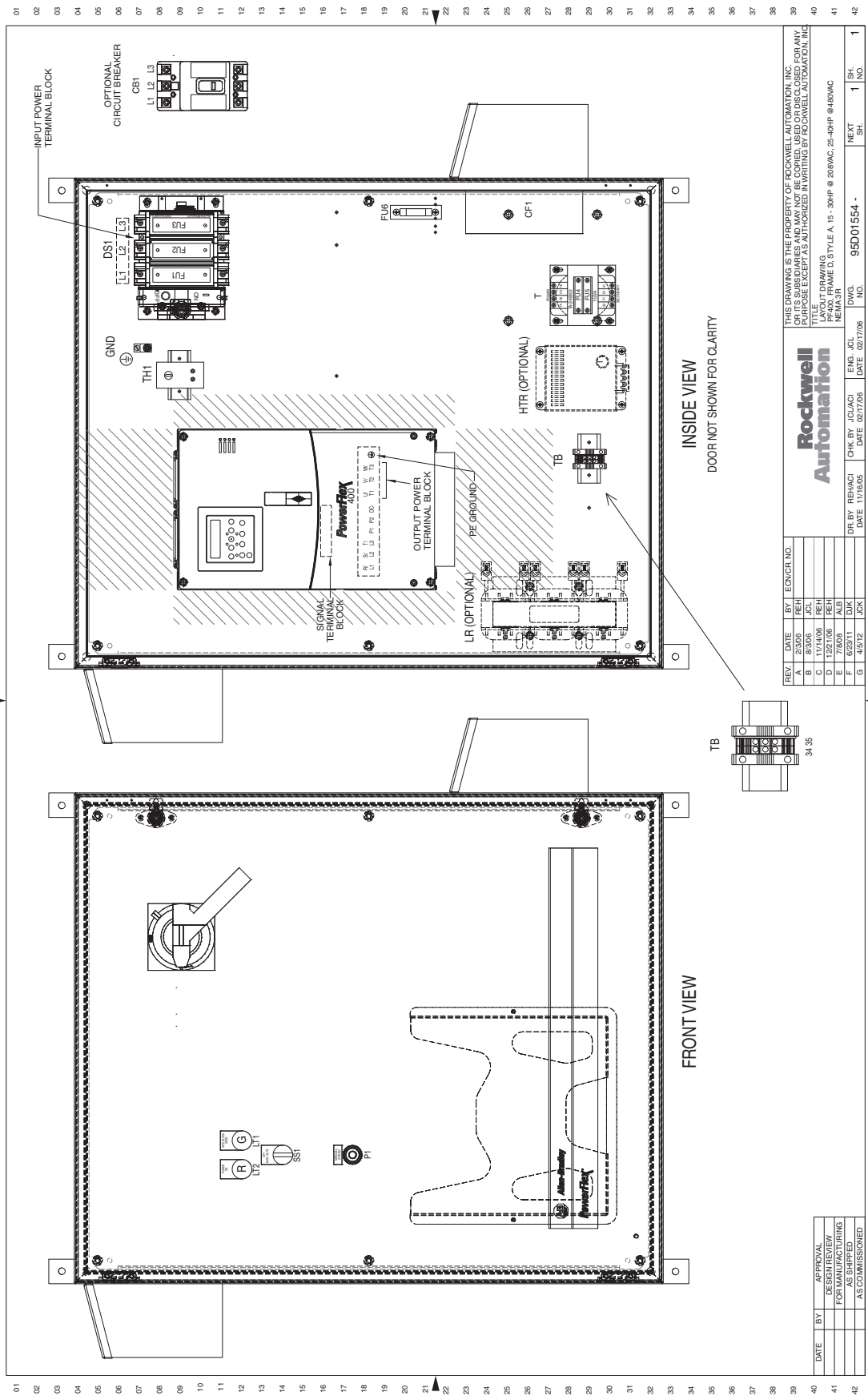
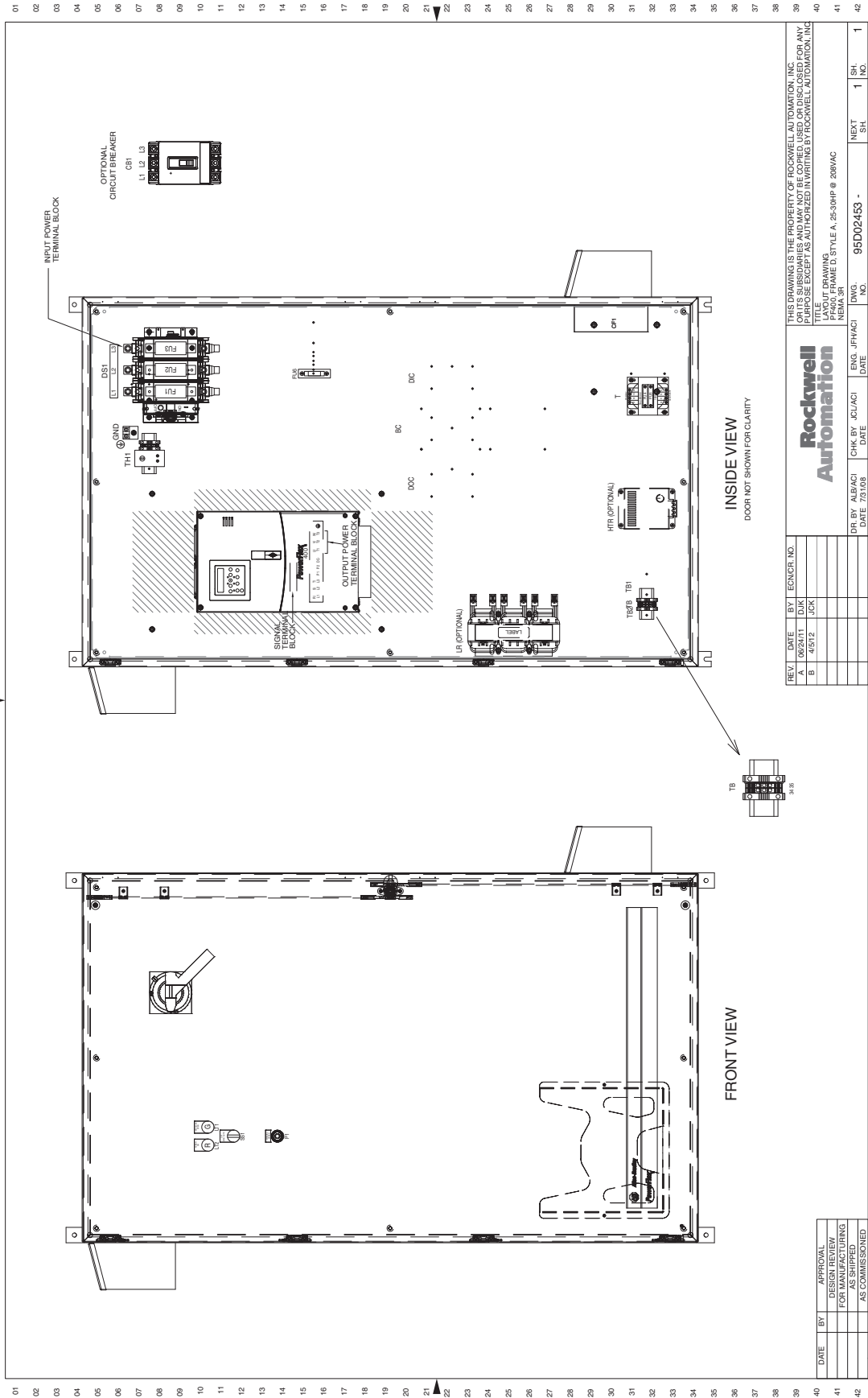

Figure 44 - 25...30 Hp, 208V AC Drives - NEMA/UL Type 3R



THIS DRAWING IS THE PROPERTY OF ROCKWELL AUTOMATION, INC. OR ITS SUBSIDIARIES AND MAY NOT BE COPIED, REPRODUCED, OR DISCLOSED FOR ANY PURPOSES WITHOUT THE WRITTEN PERMISSION OF ROCKWELL AUTOMATION, INC.

TITLE: LAYOUT DRAWING
PART NAME: STYLE A, 25-30HP @ 208VAC
NEMA 3R

REV.	DATE	BY	ECNCR. NO.
A	09/24/11	DJK	
B	4/25/12	JCK	

DR. BY	ALB/ACI	CHK. BY	JCL/ACI
DATE	7/3/08	DATE	

ENG.	JFH/ACI	DWG. NO.	95D02453
DATE		NO.	

SH.	1	SH.	1
NO.		NO.	

DATE	BY	APPROVAL
		DESIGN REVIEW
		FOR MANUFACTURING
		AS SHIPPED
		AS COMMISSIONED

Figure 45 - 40...50 Hp, 208V AC Drives - NEMA/UL Type 3R

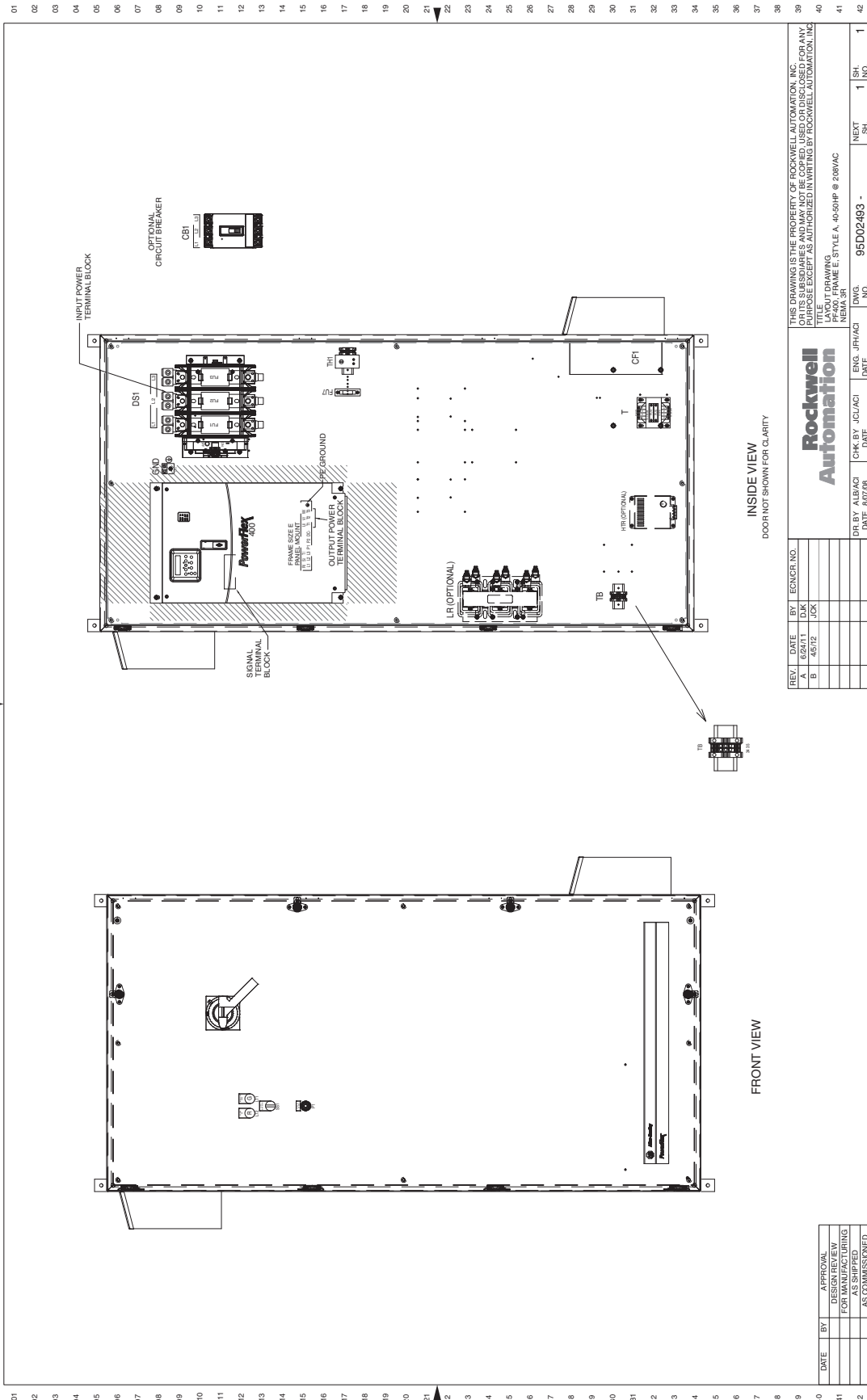

INSIDE VIEW
DOOR NOT SHOWN FOR CLARITY

FRONT VIEW

REV.	DATE	BY	ECNCR. NO.
A	5/24/11	DK	
B	4/27/12	JOK	

DATE	BY	APPROVAL
		DESIGN REVIEW FOR MANUFACTURING AS SHIPPED AS COMMISSIONED

DR BY	ALB/ACI	DATE	CHK BY	JG/L/ACI	DATE	ENG	JPH/ACI	DATE	DWG.	NO.	1SH.	1	IND.
										95D02493			

THIS DRAWING IS THE PROPERTY OF ROCKWELL AUTOMATION, INC. IT IS TO BE USED FOR THE SPECIFIC PROJECT AND FOR ANY PURPOSE EXCEPT AS AUTHORIZED IN WRITING BY ROCKWELL AUTOMATION, INC.

TITLE: T DRAWING
PART: PF400, FRAME E, STYLE A, 40-50HP @ 208VAC
NEMA 3R

Figure 46 - 50...60 Hp, 460V AC Drives - NEMA/UL Type 3R

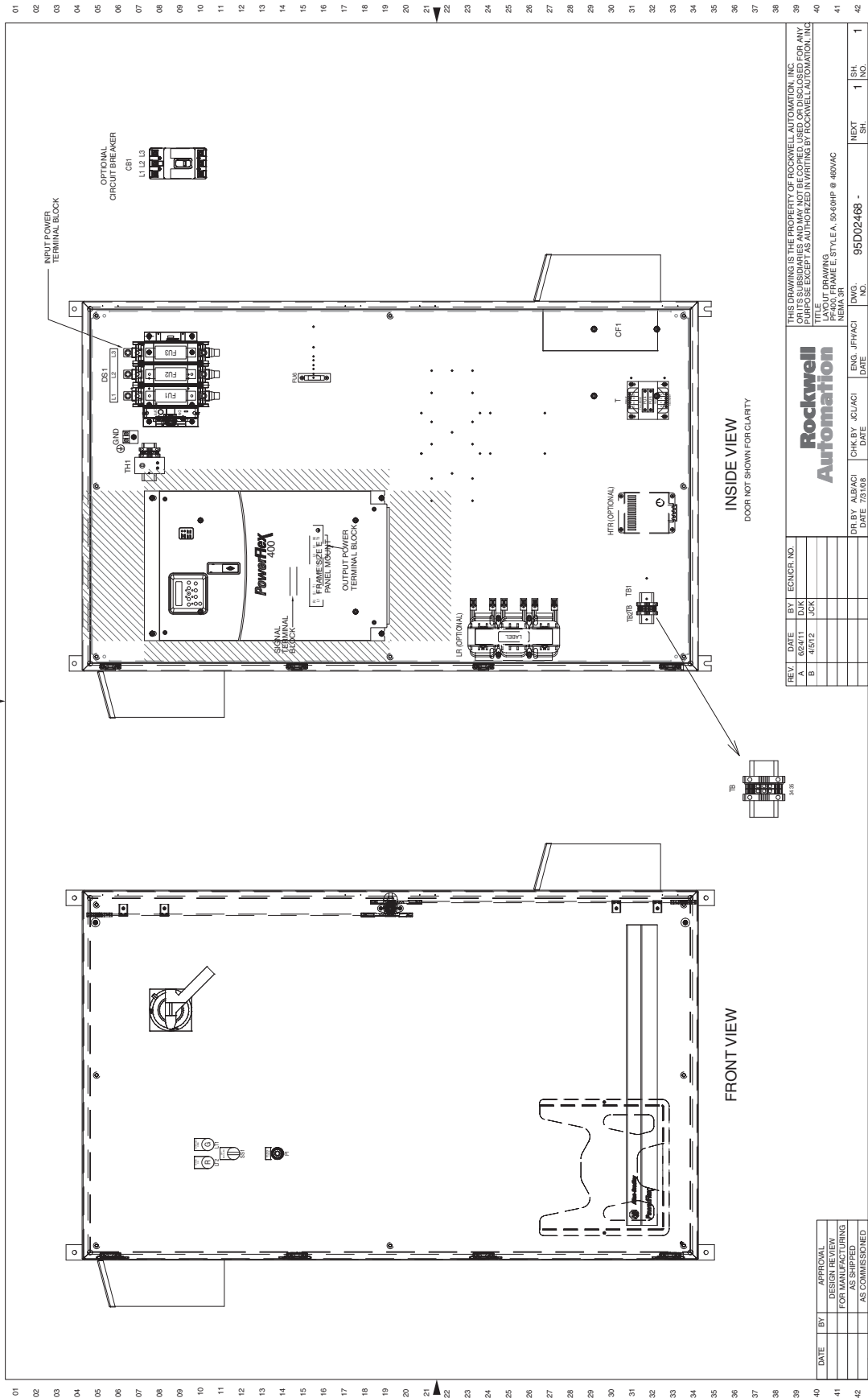

01
02
03
04
05
06
07
08
09
10
11
12
13
14
15
16
17
18
19
20
21
22
23
24
25
26
27
28
29
30
31
32
33
34
35
36
37
38
39
40
41
42

REV.	DATE	BY	ECNCR. NO.
A	6/24/11	DJK	
B	4/5/12	JCK	

DR. BY	ALB/ACI	DATE	7/3/08
CHK. BY	JCL/ACI	DATE	
ENG.	JFH/ACI	DATE	
DWG. NO.	95D02468	DWG. NO.	
NEXT SH.	1	SH. NO.	1

THIS DRAWING IS THE PROPERTY OF ROCKWELL AUTOMATION, INC. OR ITS SUBSIDIARIES AND MAY NOT BE COPIED, USED, REPRODUCED, OR TRANSMITTED IN ANY FORM OR BY ANY MEANS, ELECTRONIC OR MECHANICAL, INCLUDING PHOTOCOPYING, RECORDING, OR BY ANY INFORMATION STORAGE AND RETRIEVAL SYSTEM. WITHOUT THE WRITTEN PERMISSION OF ROCKWELL AUTOMATION, INC.

DATE	BY	APPROVAL
		DESIGN REVIEW
		FOR MANUFACTURING
		AS SHIPPED
		AS COMMISSIONED

01
02
03
04
05
06
07
08
09
10
11
12
13
14
15
16
17
18
19
20
21
22
23
24
25
26
27
28
29
30
31
32
33
34
35
36
37
38
39
40
41
42

Figure 47 - 75...100 Hp, 460V AC Drives - NEMA/UL Type 3R

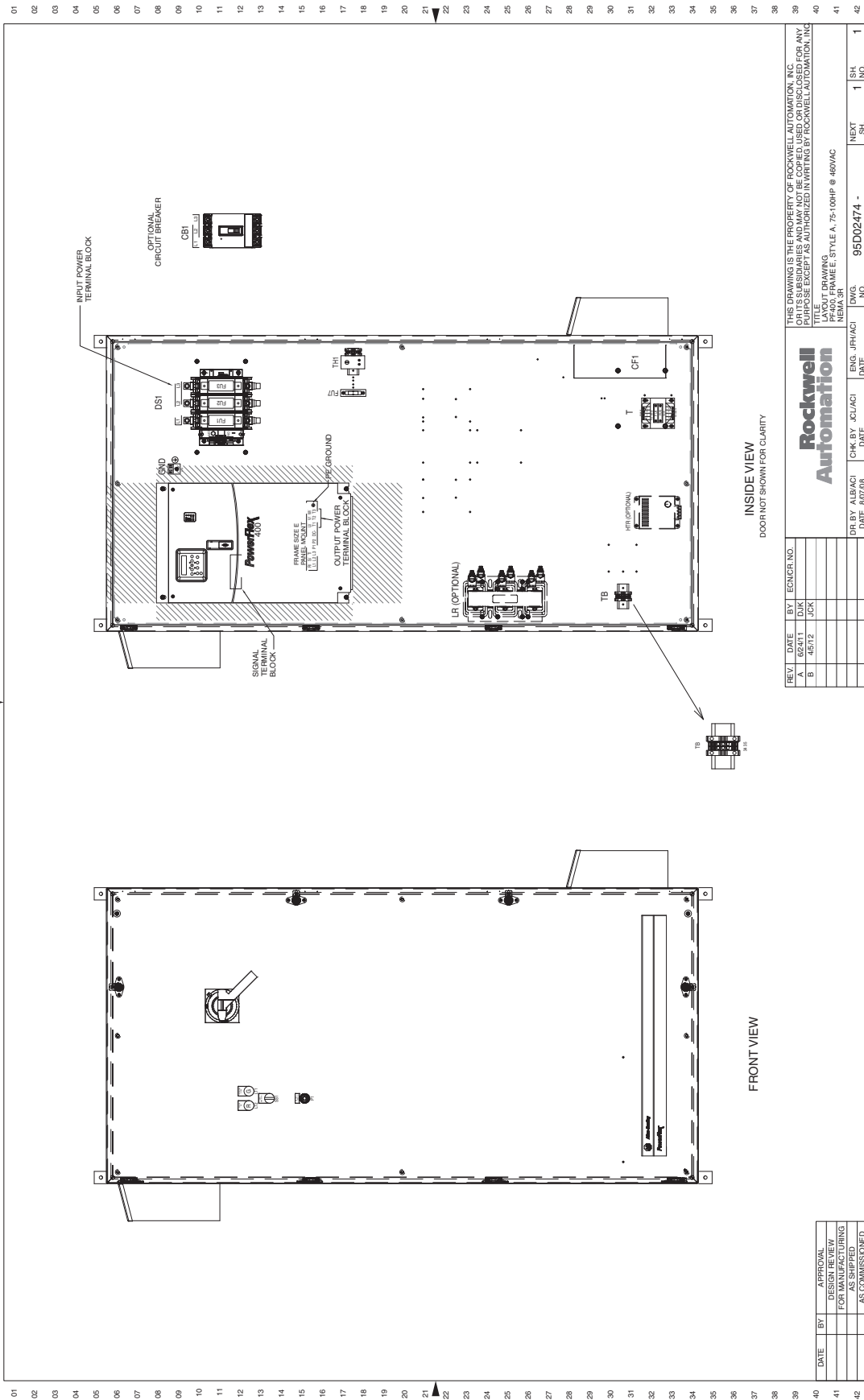
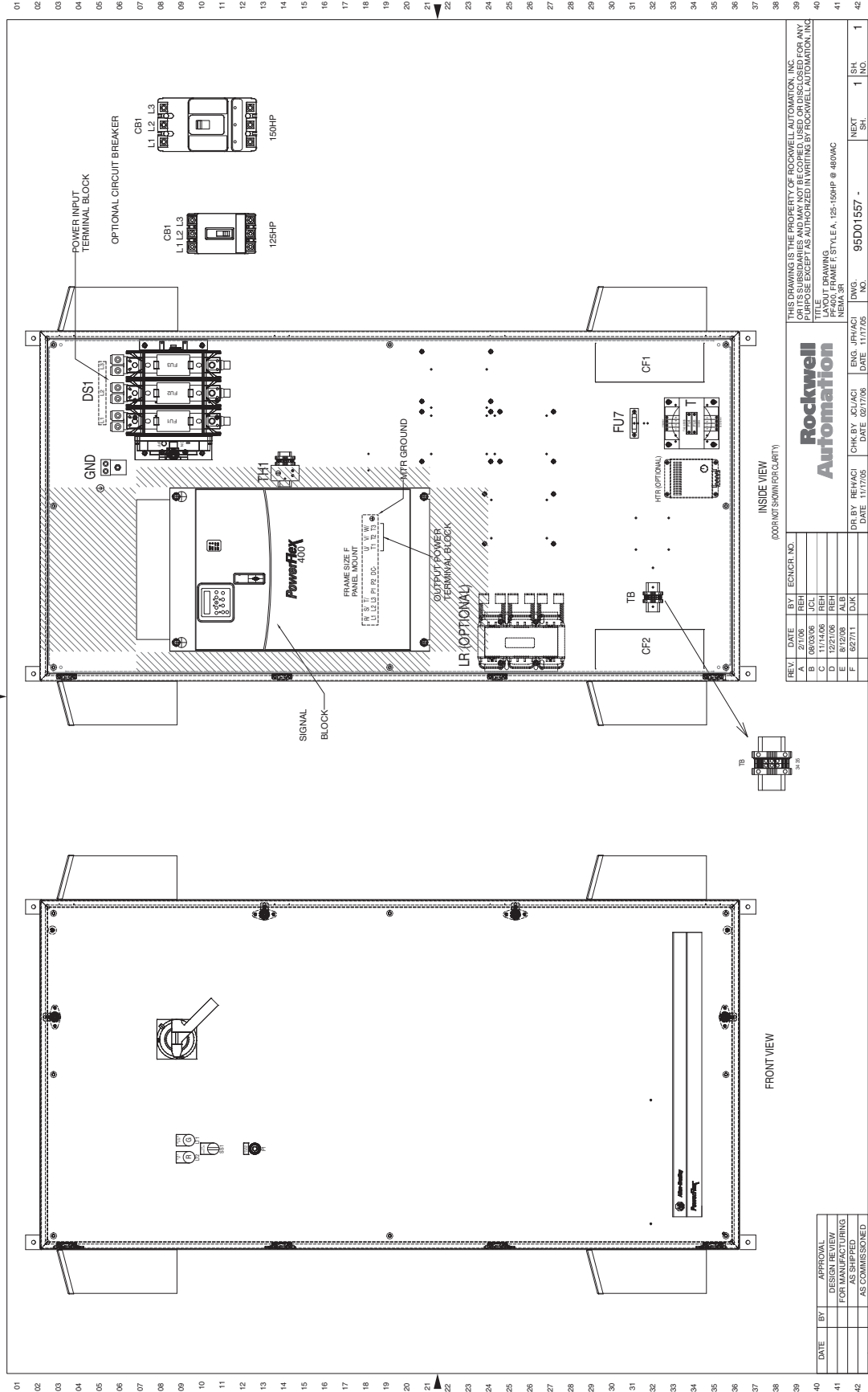

Figure 48 - 125...150 Hp, 460V AC Drives - NEMA/UL Type 3R



THIS DRAWING IS THE PROPERTY OF ROCKWELL AUTOMATION, INC. OR ITS SUBSIDIARIES AND MAY NOT BE COPIED, USED, REPRODUCED, OR TRANSMITTED IN ANY FORM OR BY ANY MEANS, WITHOUT THE EXPRESS WRITTEN PERMISSION OF ROCKWELL AUTOMATION, INC.

TITLE: MAIN INPUT DISCONNECT PACKAGE (STYLE A/M) 125-150HP @ 460VAC

LAYOUT DRAWING

NO. 95D01557 -

REV.	DATE	BY	ENGR. NO.
A	2/7/06	REH	
B	08/03/06	JCL	
C	12/27/06	REH	
D	8/12/08	ALB	
E	8/27/11	DJK	
F	6/27/11	DJK	

DR. BY	REH/ACI	ENG. JRM/ACI	DWG. NO.
DATE	11/17/05	DATE	11/17/05
CHK. BY	JCL/ACI	NO.	95D01557 -
DATE	11/17/05	DATE	11/17/05
SH.	1	SH.	1
NO.		NO.	

DATE	BY	APPROVAL
		FOR MANUFACTURING
		AS SHIPPED
		AS COMMISSIONED

01
02
03
04
05
06
07
08
09
10
11
12
13
14
15
16
17
18
19
20
21
22
23
24
25
26
27
28
29
30
31
32
33
34
35
36
37
38
39
40
41
42

Outline Drawings

Figure 49 - 3.0...10 Hp, 208V AC and 3.0...20 Hp, 460V AC Drives - NEMA/UL Type 1

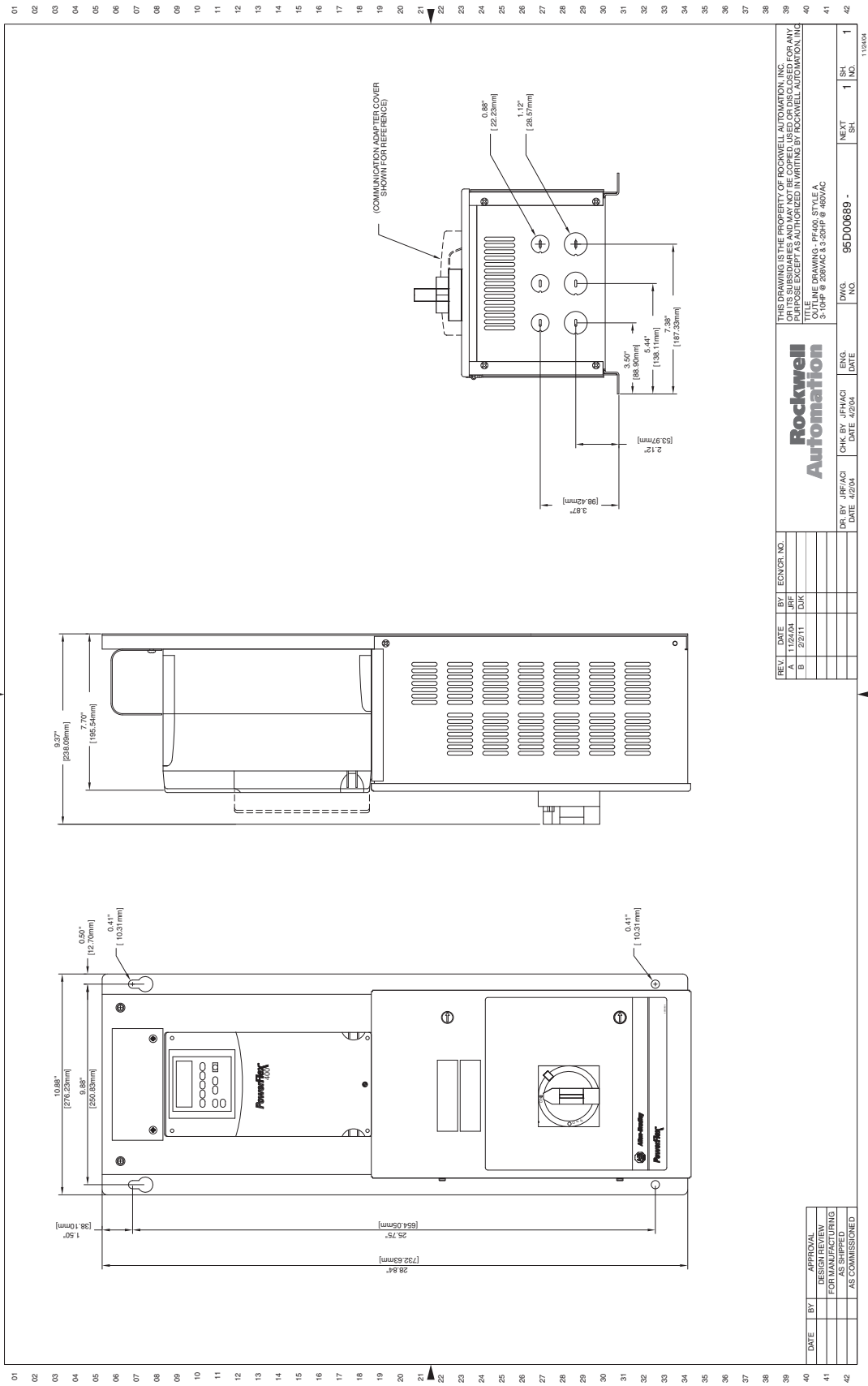

Figure 50 - 15...20 Hp, 208V AC and 25...40 Hp, 460V AC Drives - NEMA/UL Type 1

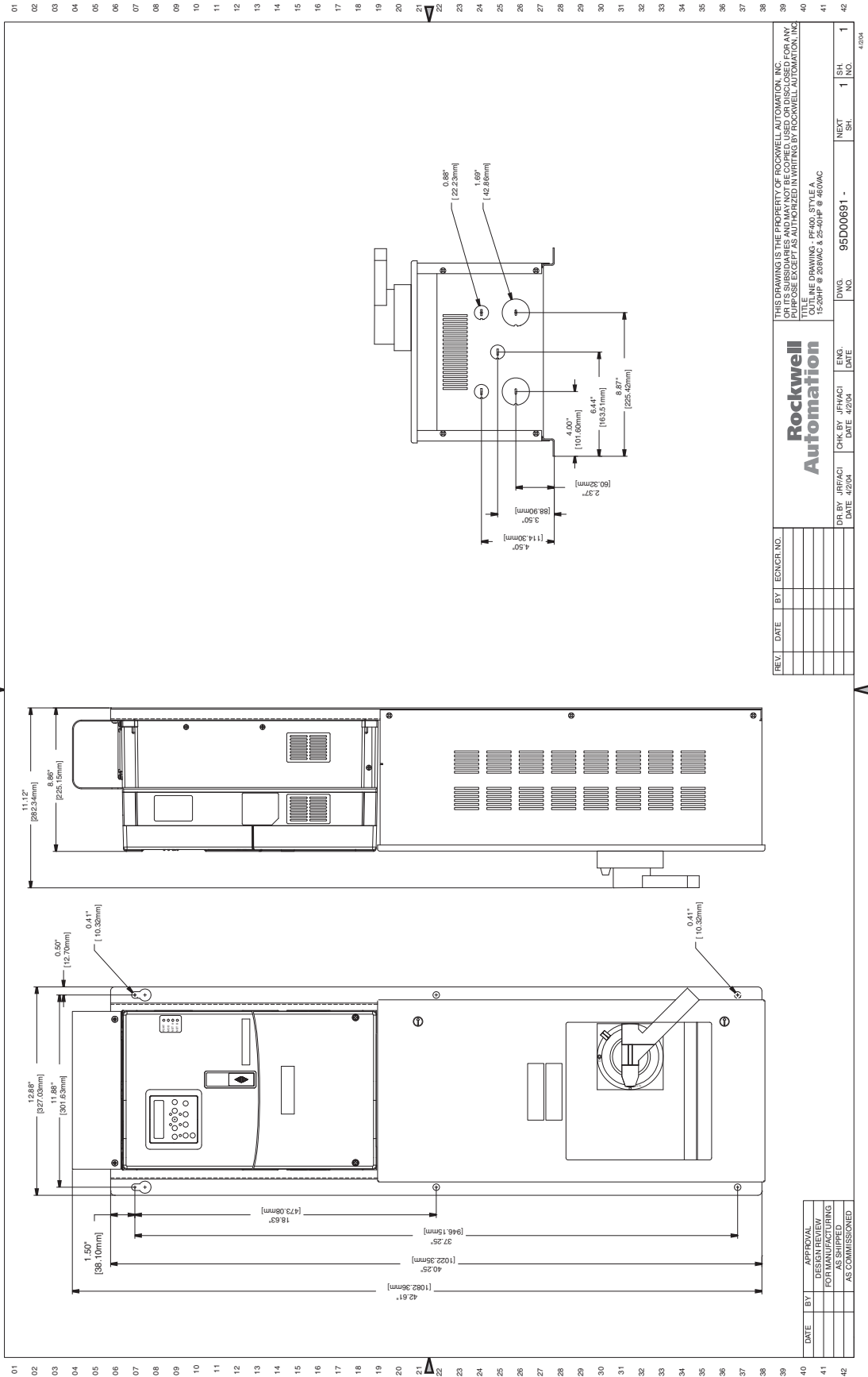

Figure 51 - 25...30 Hp, 208V AC Drives - NEMA/UL Type 1

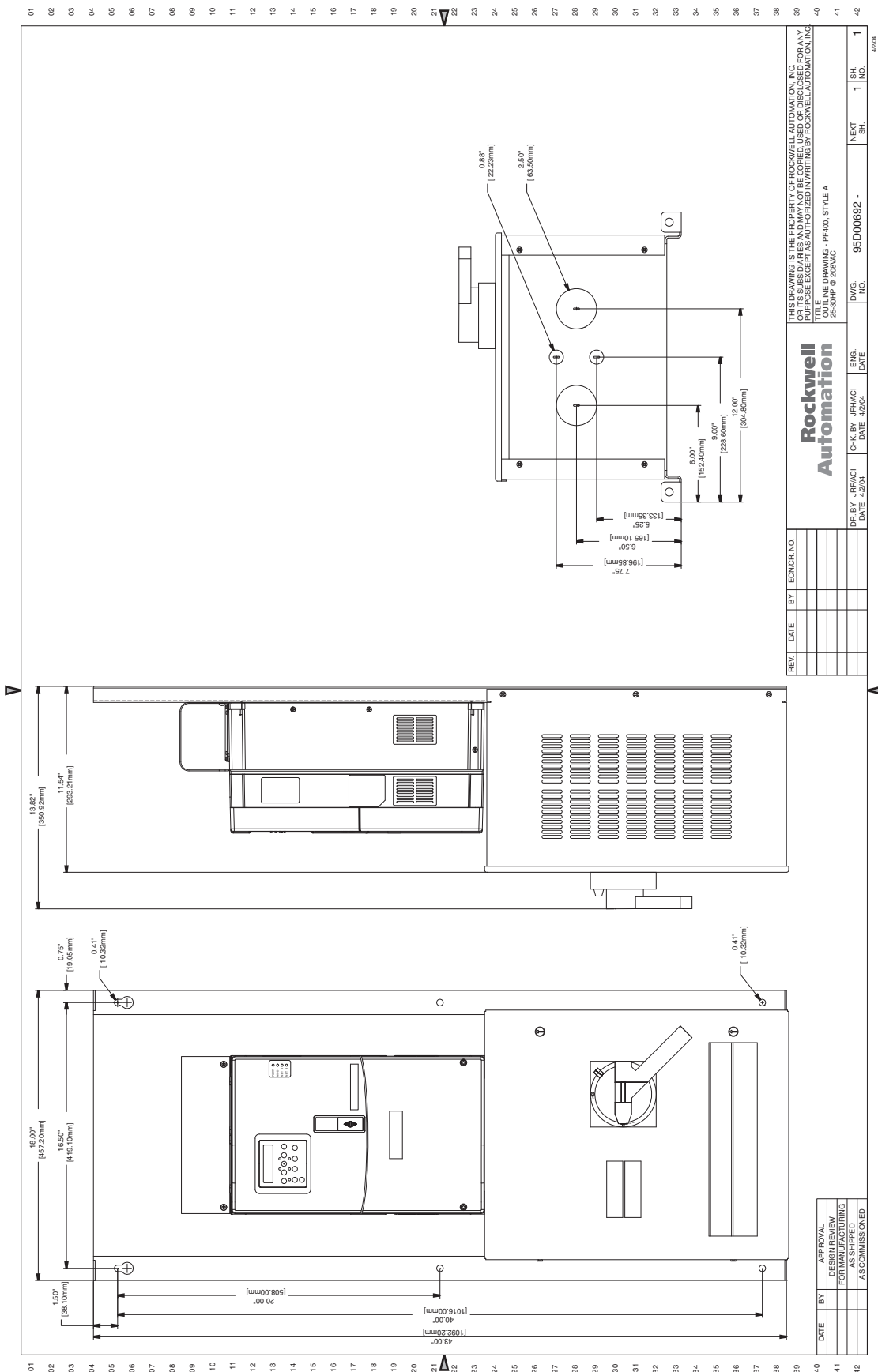

Figure 52 - 40 Hp, 208V AC and 50...100 Hp, 460V AC Drives - NEMA/UL Type 1

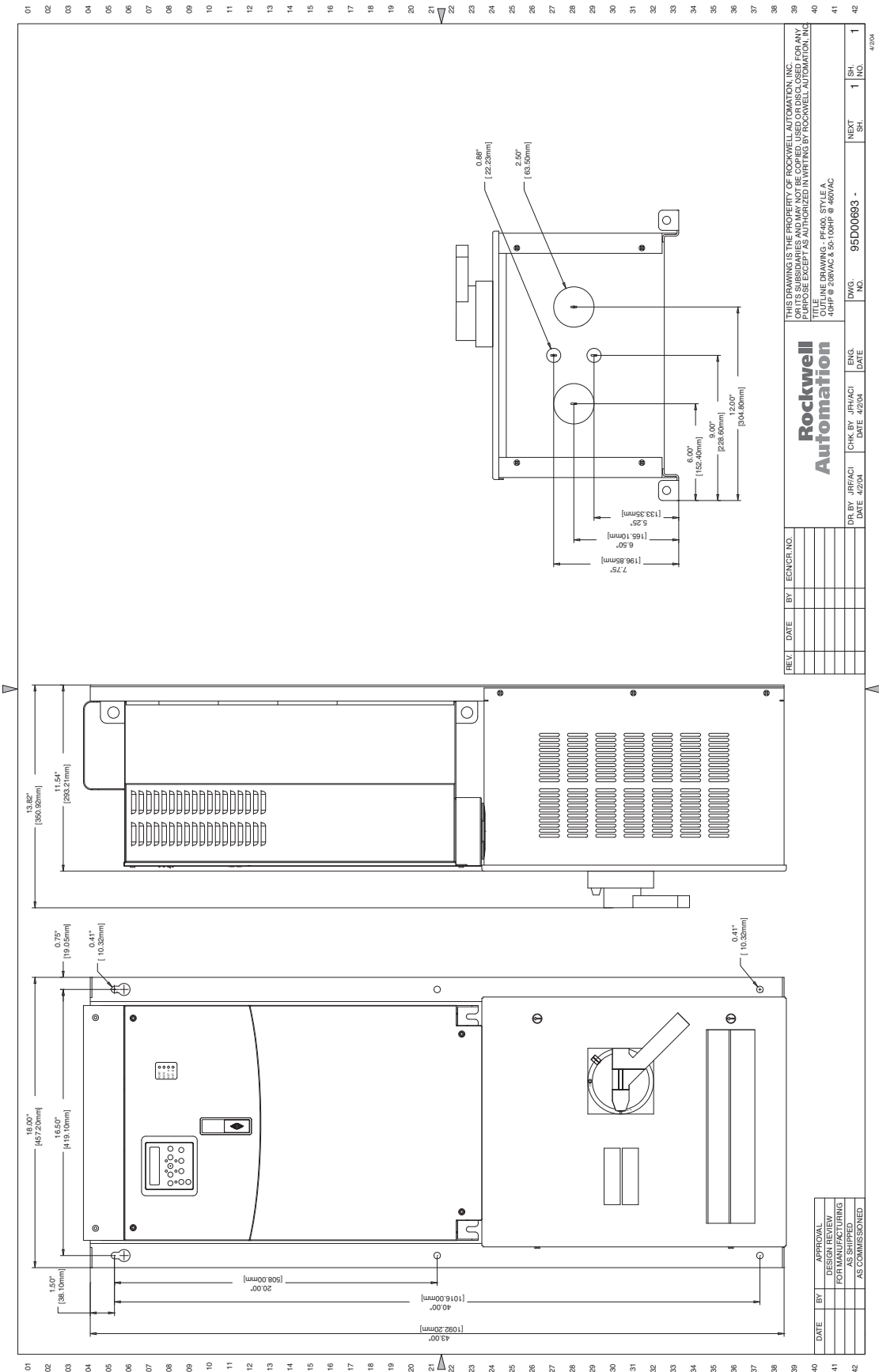
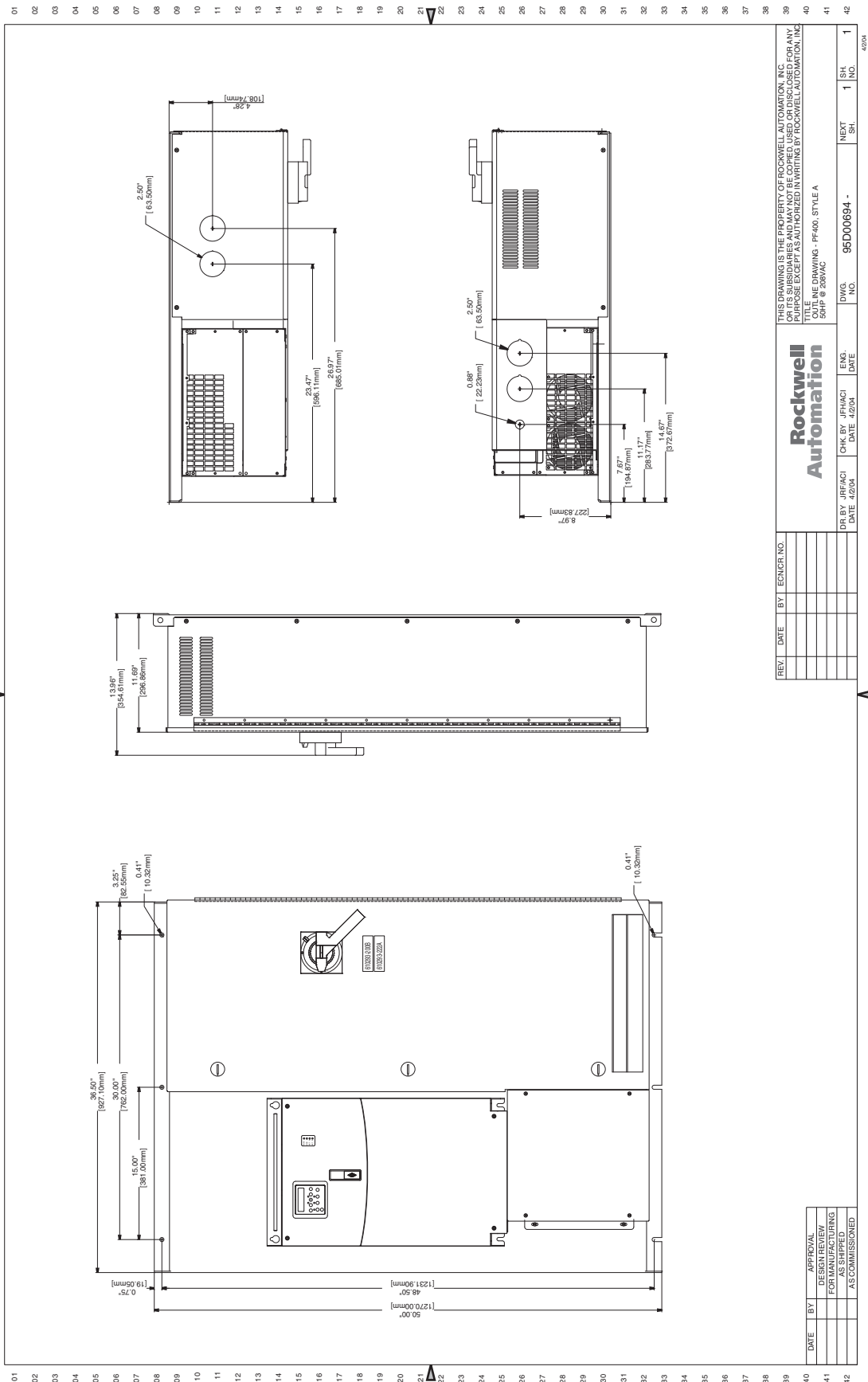

Figure 53 - 50 Hp, 208V AC Drives - NEMA/UL Type 1



REV.	DATE	BY	ECNCR. NO.	DR. BY	JRH/ACI	DATE	4/2/04	CHK. BY	JRH/ACI	DATE	4/2/04	ENG. DATE	DWG. NO.	95D00694 -	NEXT SH.	1	ISL	1

THIS DRAWING IS THE PROPERTY OF ROCKWELL AUTOMATION, INC. NO PART OF THIS DRAWING IS TO BE REPRODUCED OR TRANSMITTED IN ANY FORM OR BY ANY MEANS, ELECTRONIC OR MECHANICAL, INCLUDING PHOTOCOPYING, RECORDING, OR BY ANY INFORMATION STORAGE AND RETRIEVAL SYSTEM, WITHOUT THE WRITTEN PERMISSION OF ROCKWELL AUTOMATION, INC.

TITLE: ME DRAWING - PF400, STYLE A
50HP @ 208VAC

Figure 54 - 125...150 Hp, 460V AC Drives - NEMA/UL Type 1

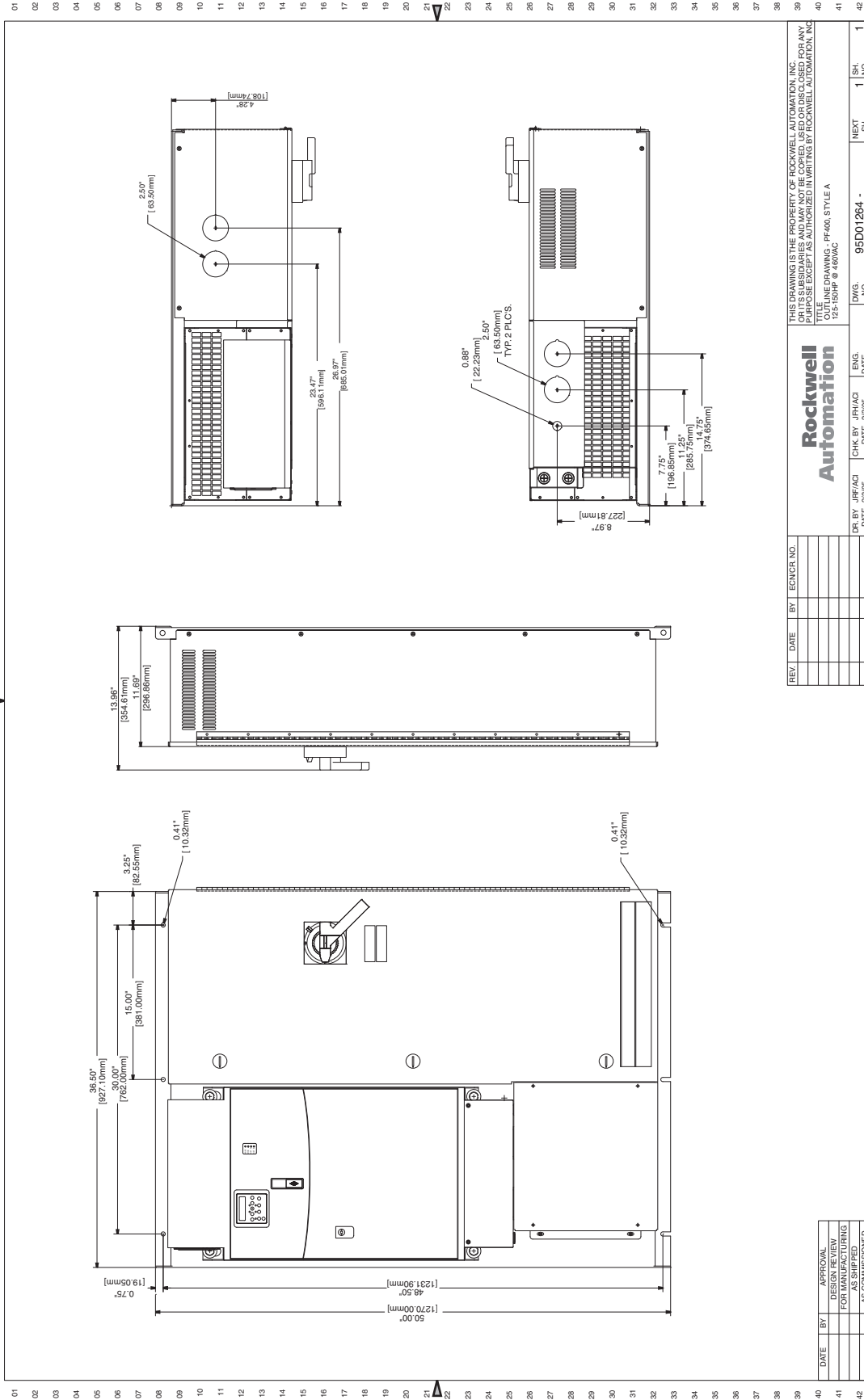

REV.		DATE	BY	ECONCR. NO.	DR. BY: JRF/ACJ DATE: 2/3/05		CHK. BY: JRH/ACI DATE: 2/3/05		ENG. DATE	DWG. NO.	95D01264	1	1	1	1
THIS DRAWING IS THE PROPERTY OF ROCKWELL AUTOMATION, INC. IT IS THE PROPERTY OF ROCKWELL AUTOMATION, INC. AND IS NOT TO BE REPRODUCED OR TRANSMITTED IN ANY FORM OR BY ANY MEANS, ELECTRONIC OR MECHANICAL, INCLUDING PHOTOCOPYING, RECORDING, OR BY ANY INFORMATION STORAGE AND RETRIEVAL SYSTEM, WITHOUT THE WRITTEN PERMISSION OF ROCKWELL AUTOMATION, INC. TITLE: OUTFIT DRAWING - PPH00, STYLE A 125...150HP @ 460VAC															
Rockwell Automation															
APPROVAL FOR MANUFACTURING AS SHIPPED AS COMMISSIONED															

Figure 55 - 200...250 Hp, 460V AC Drives - NEMA/UL Type 1

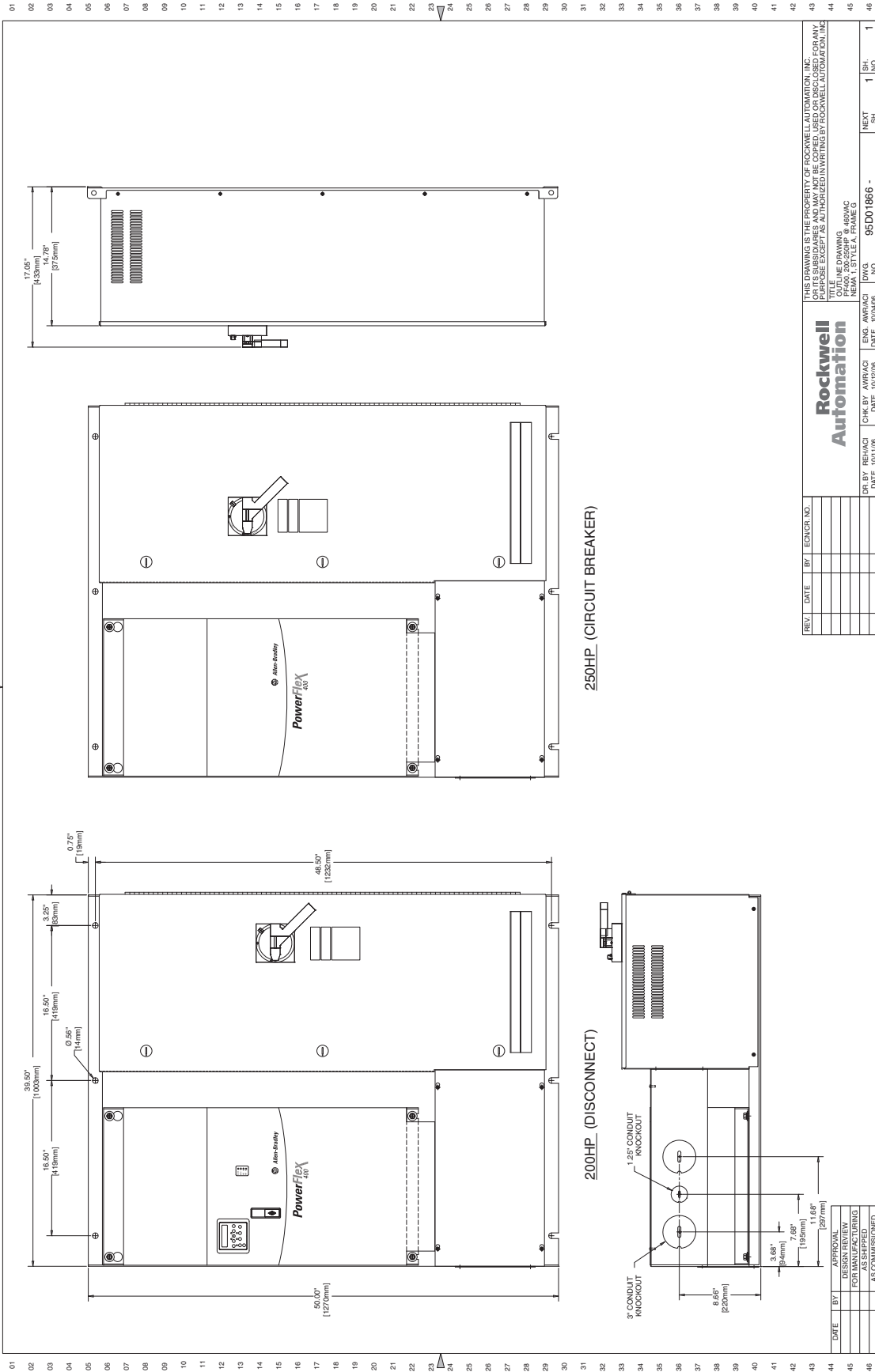

Figure 56 - 300...350 Hp, 460V AC Drives - NEMA/UL Type 1

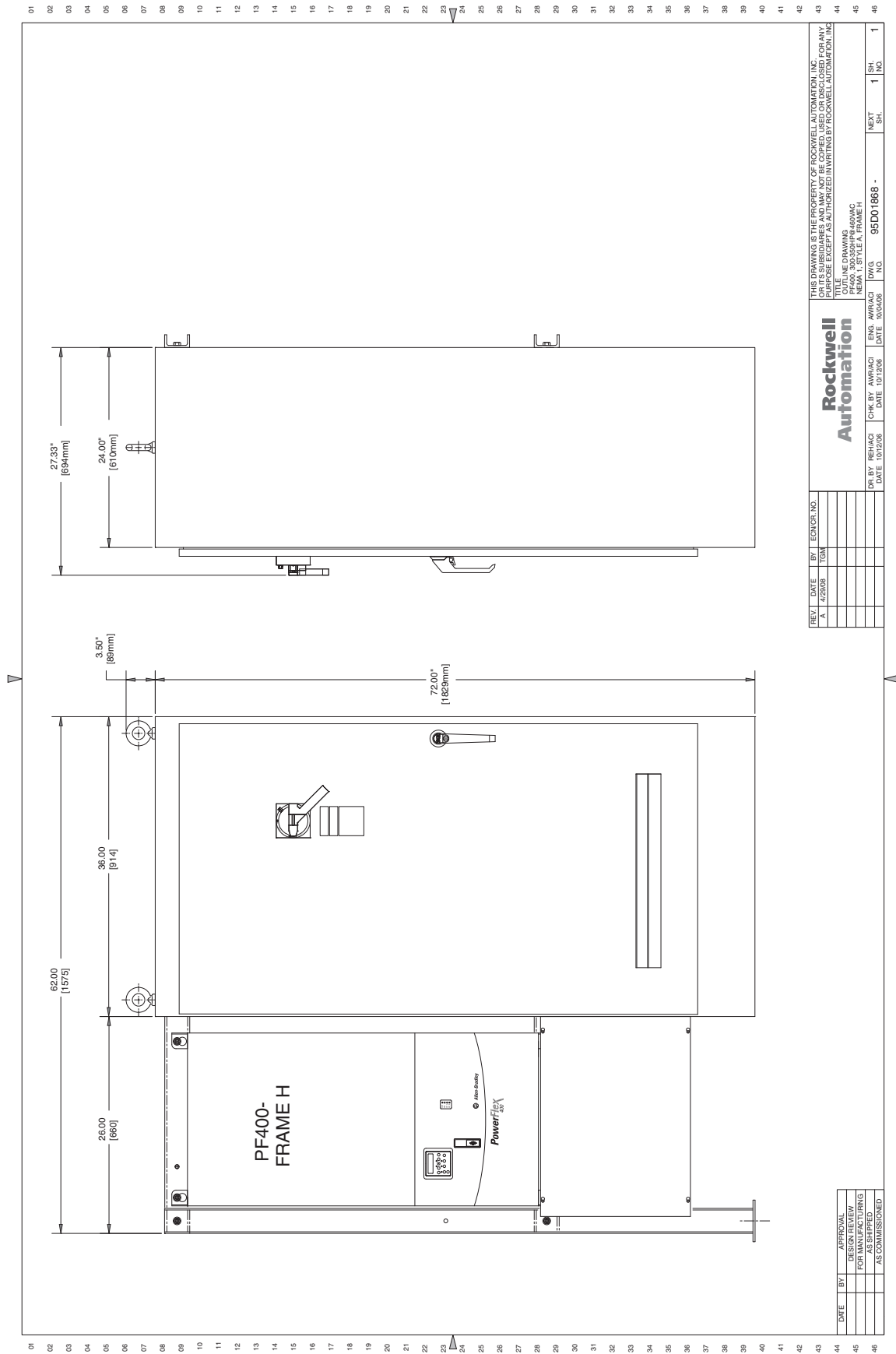

Figure 57 - 3.0...5.0 Hp, 208V AC and 3.0...10 Hp, 460V AC Drives with Line Reactor - NEMA/UL Type 1

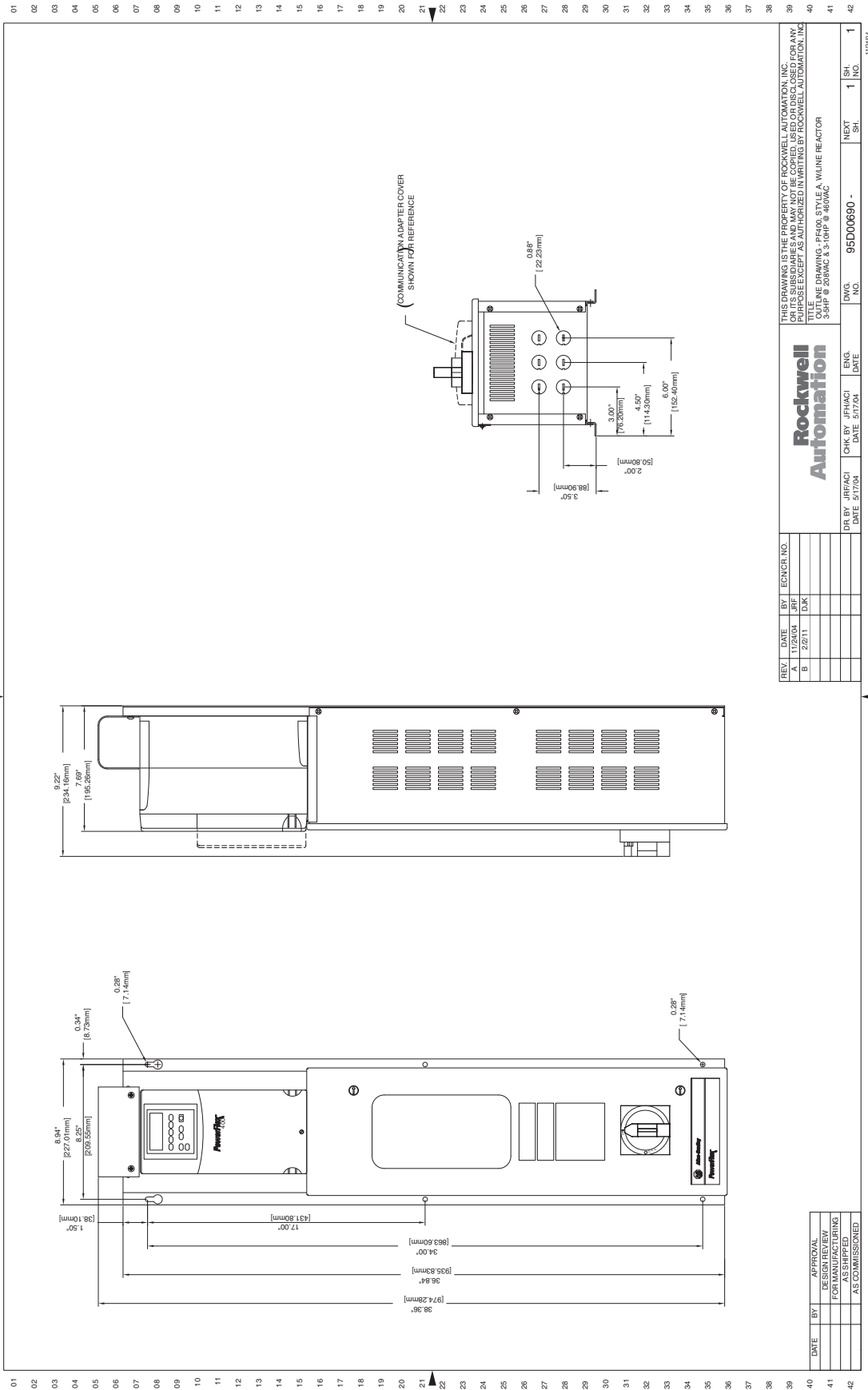

Figure 58 - 7.5...10 Hp, 208V AC and 15...20 Hp, 460V AC Drives with Line Reactor - NEMA/UL Type 1

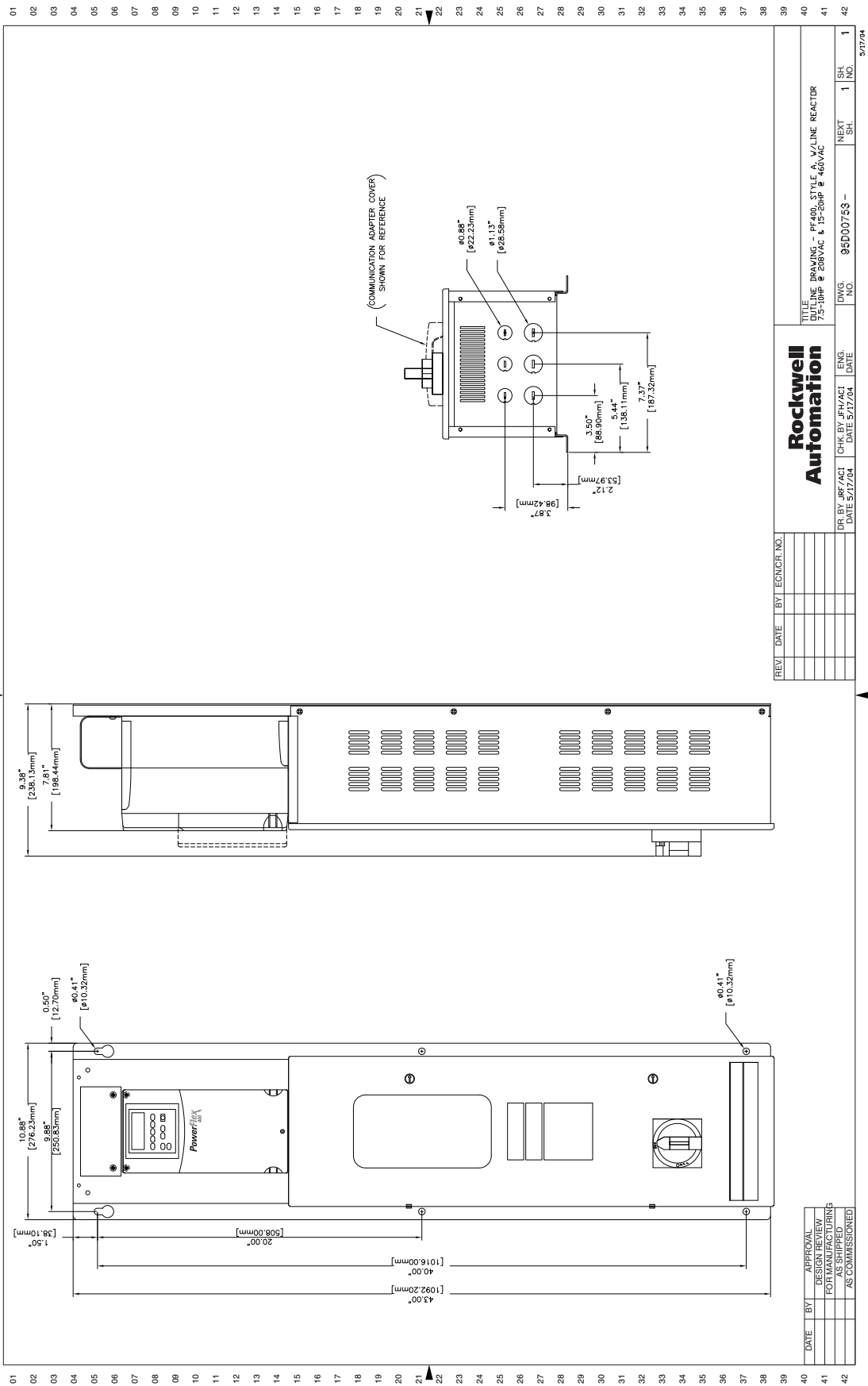

Figure 59 - 15...20 Hp, 208V AC and 25...40 Hp, 460V AC Drives with Line Reactor - NEMA/UL Type 1

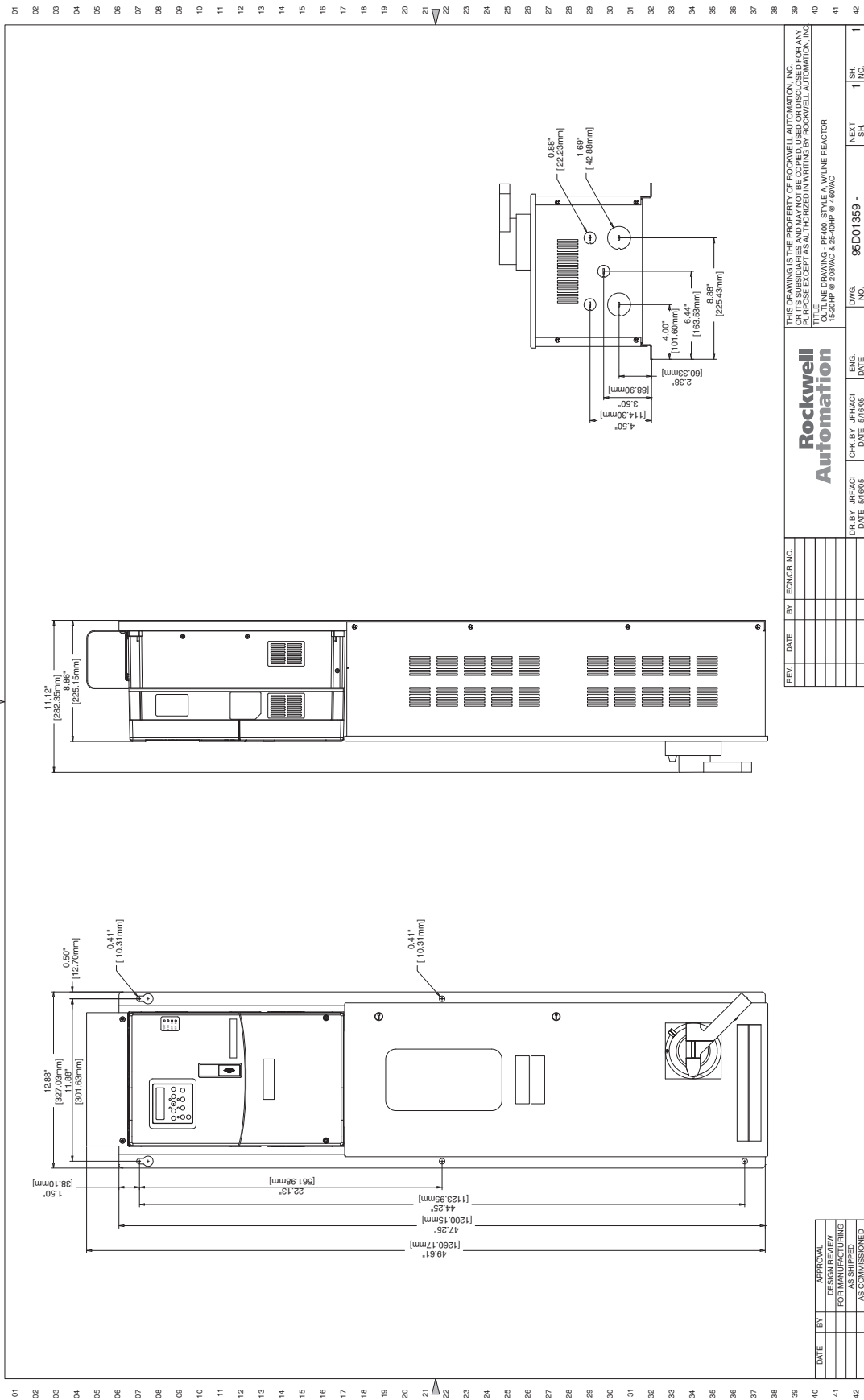

Figure 60 - 25...30 Hp, 208V AC Drives with Line Reactor - NEMA/UL Type 1

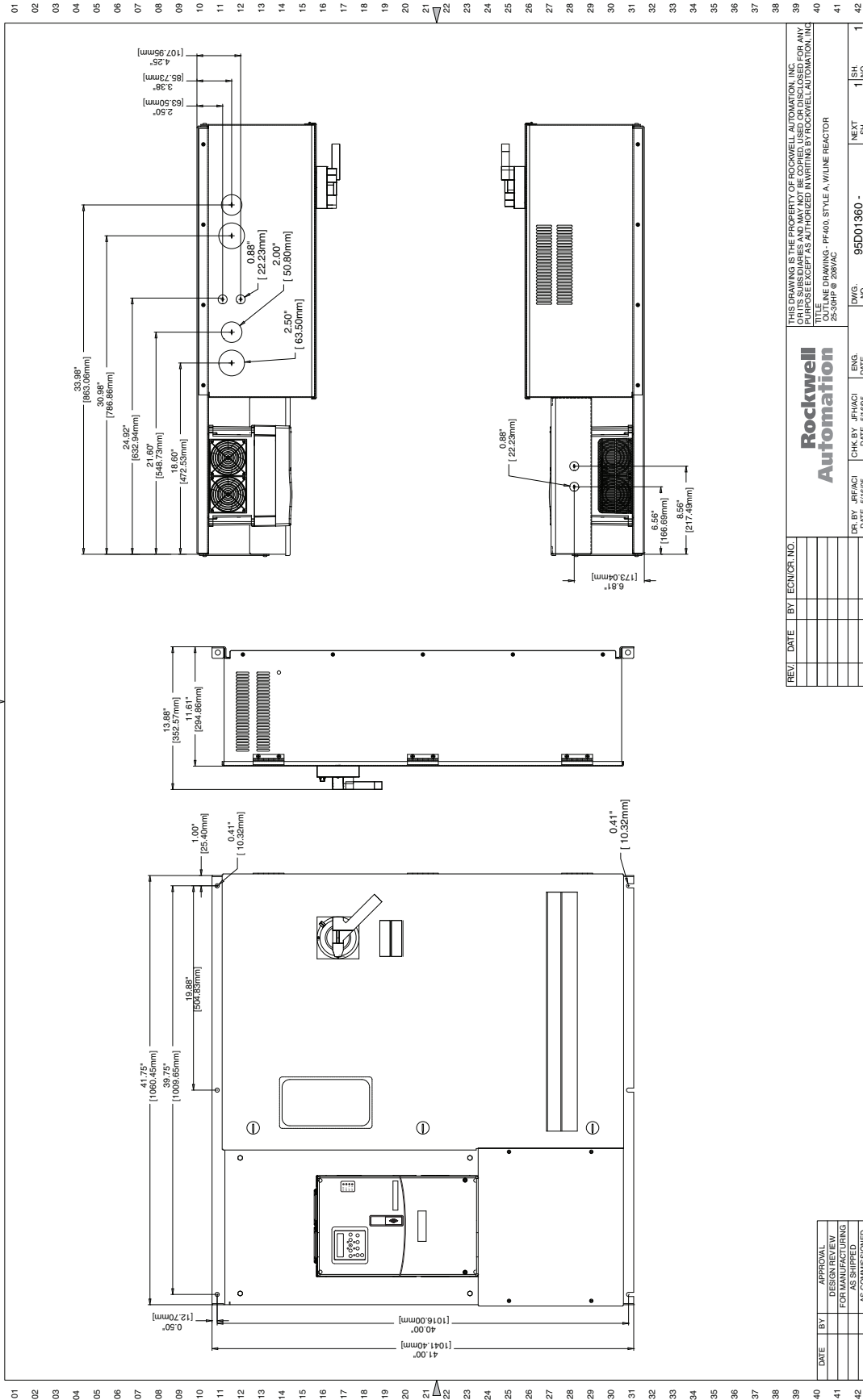

Figure 61 - 40...50 Hp, 208V AC and 50...100 Hp, 460V AC Drives with Line Reactor - NEMA/UL Type 1

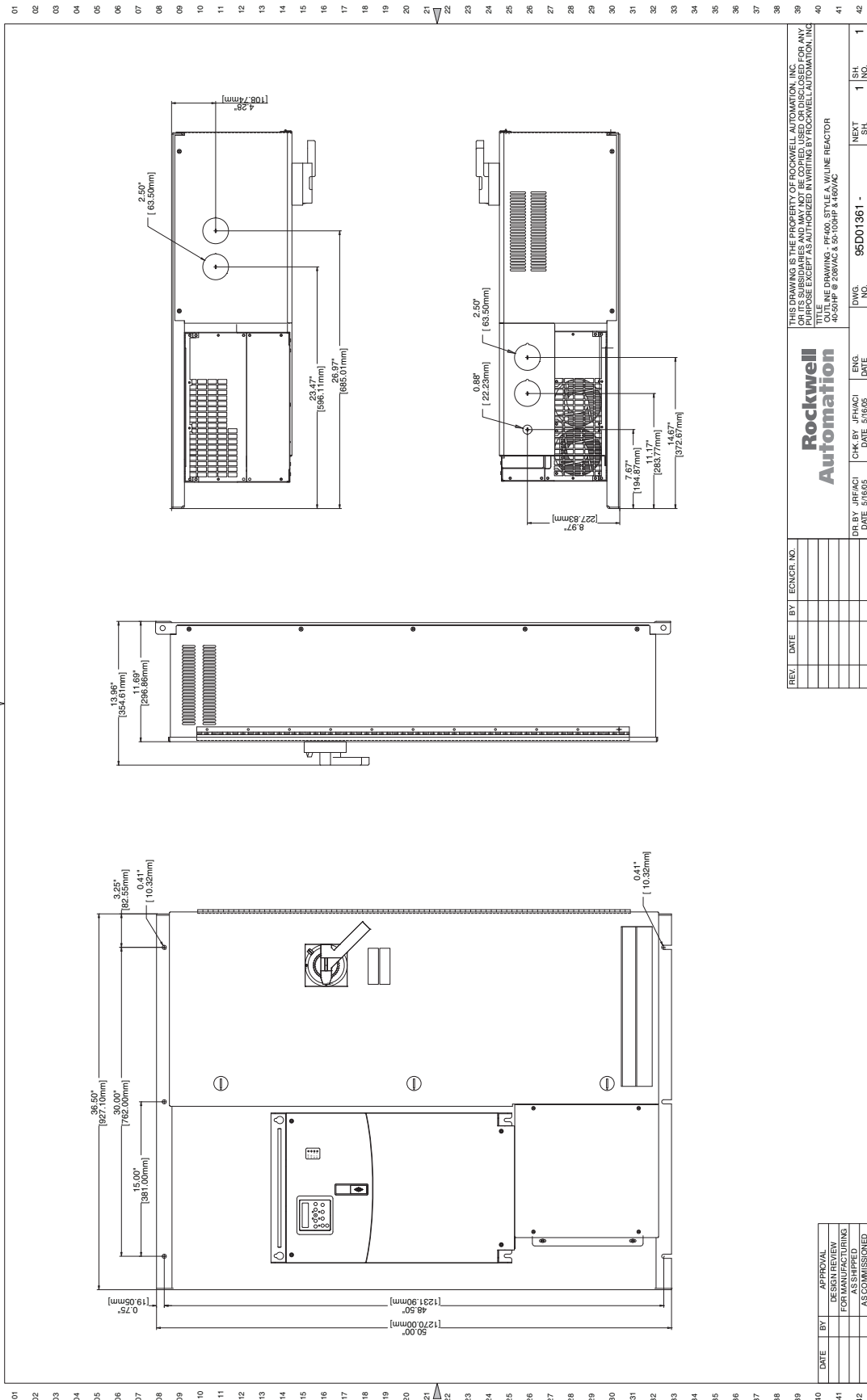

Figure 62 - 125...150 Hp, 460V AC Drives with Line Reactor - NEMA/UL Type 1

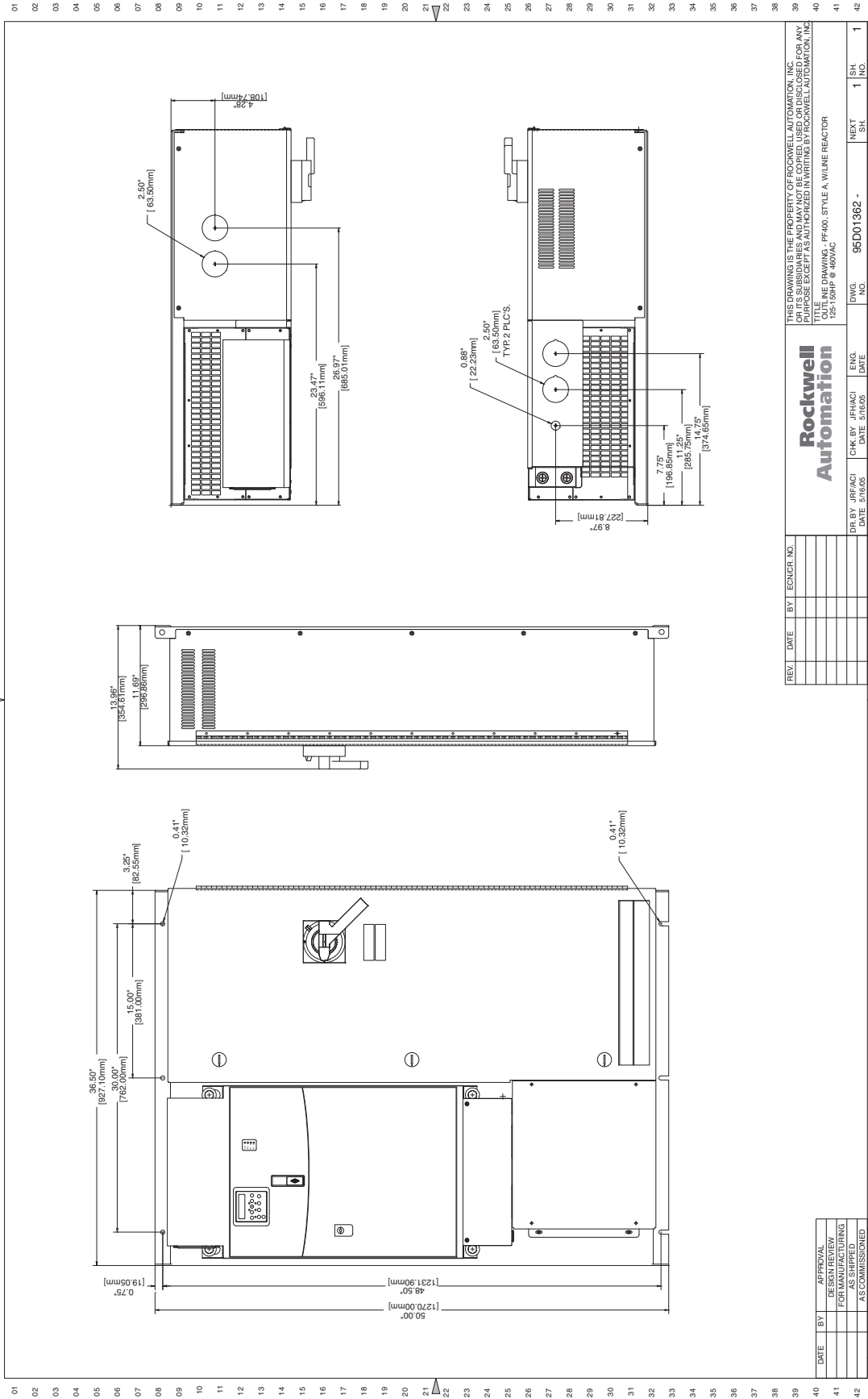

Figure 63 - 3.0...50 Hp, 208V AC and 3.0...150 Hp, 460V AC Drives - NEMA/UL Type 12

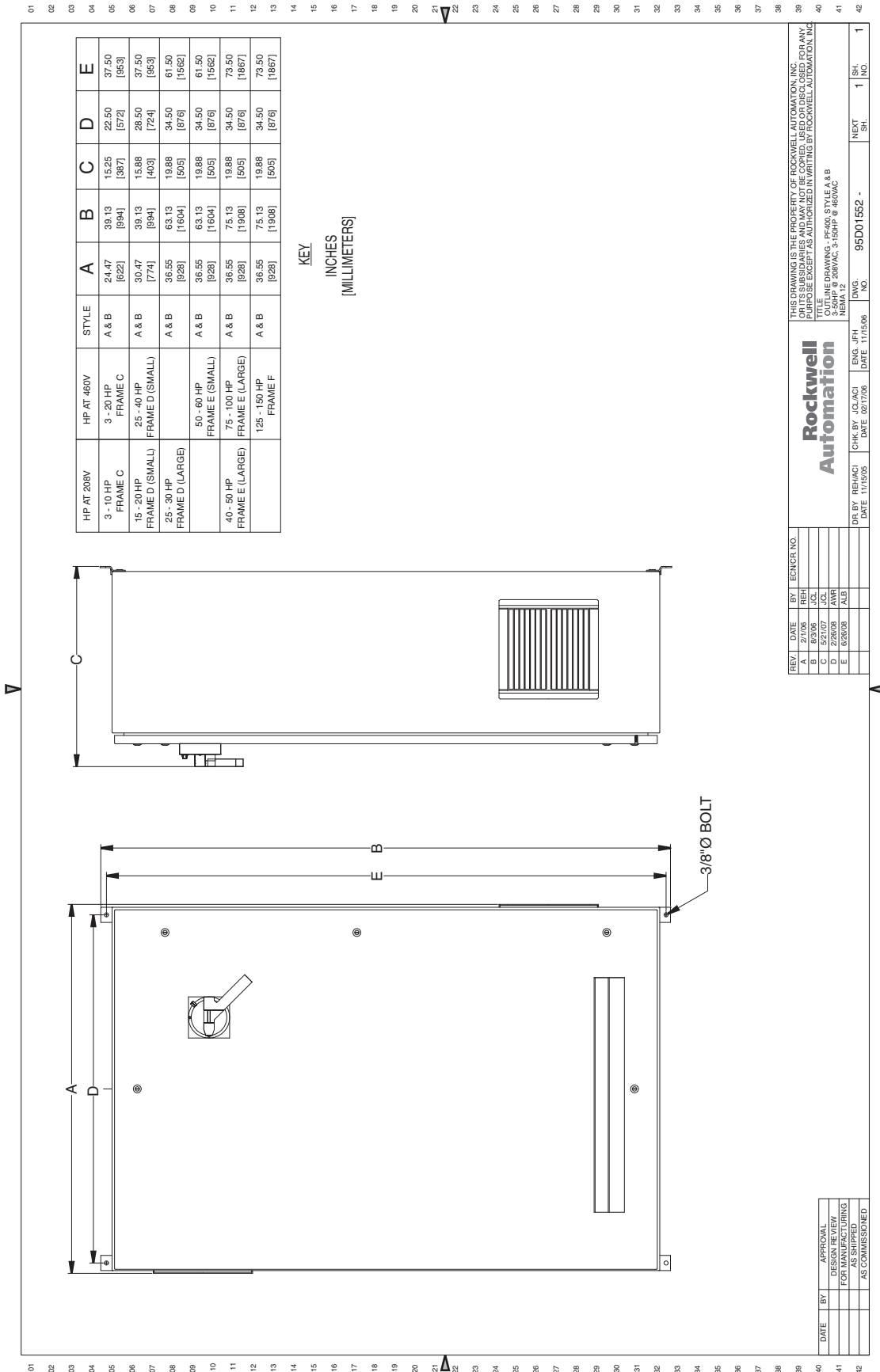
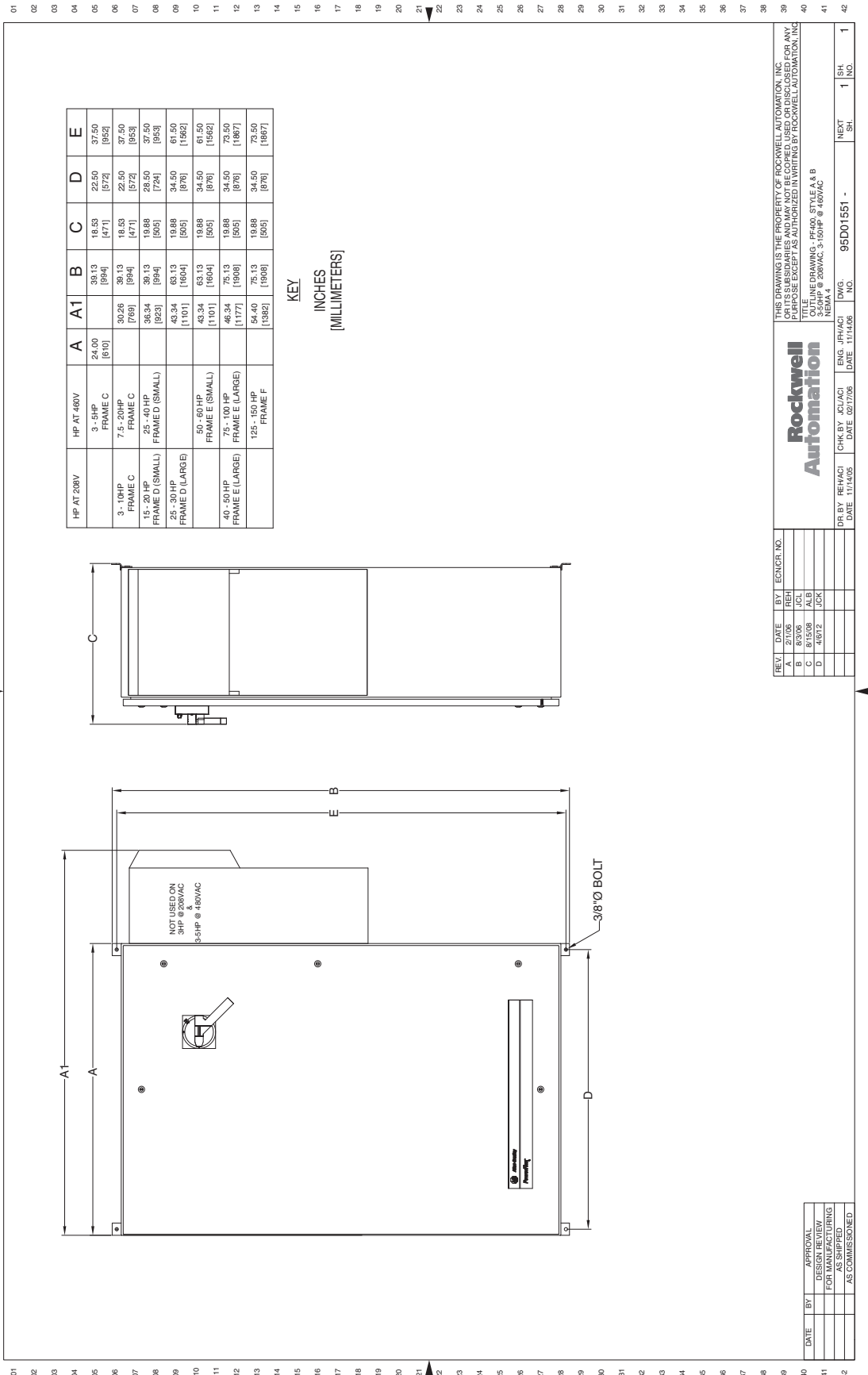

Figure 64 - 3.0...50 Hp, 208V AC and 3.0...150 Hp, 460V AC Drives - NEMA/UL Type 4



REV	DATE	BY	ECNCR. NO.	REH
A	2/1/06	JCL		
B	8/3/06	JCL		
C	4/9/12	JCL		
D	4/9/12	JCL		

THIS DRAWING IS THE PROPERTY OF ROCKWELL AUTOMATION, INC. OR ITS SUBSIDIARIES AND MAY NOT BE COPIED, USED, OR DISCLOSED FOR ANY PURPOSES WITHOUT THE WRITTEN AUTHORITY OF ROCKWELL AUTOMATION, INC.

Rockwell Automation

OUTLINE DRAWING - IPI400, STYLE A & B
NEMA 4, 3-50HP @ 460VAC

DR BY: REH/ACI DATE: 11/14/05
CHK BY: JAJ/ACI DATE: 02/17/06
ENG: JPH/ACI DATE: 11/14/06

DWG. NO. 95D01551 -
NEXT SH. 1
1 SH. 1

Figure 65 - 3.0...50 Hp, 208V AC and 3.0...150 Hp, 460V AC Drives - NEMA/UL Type 3R

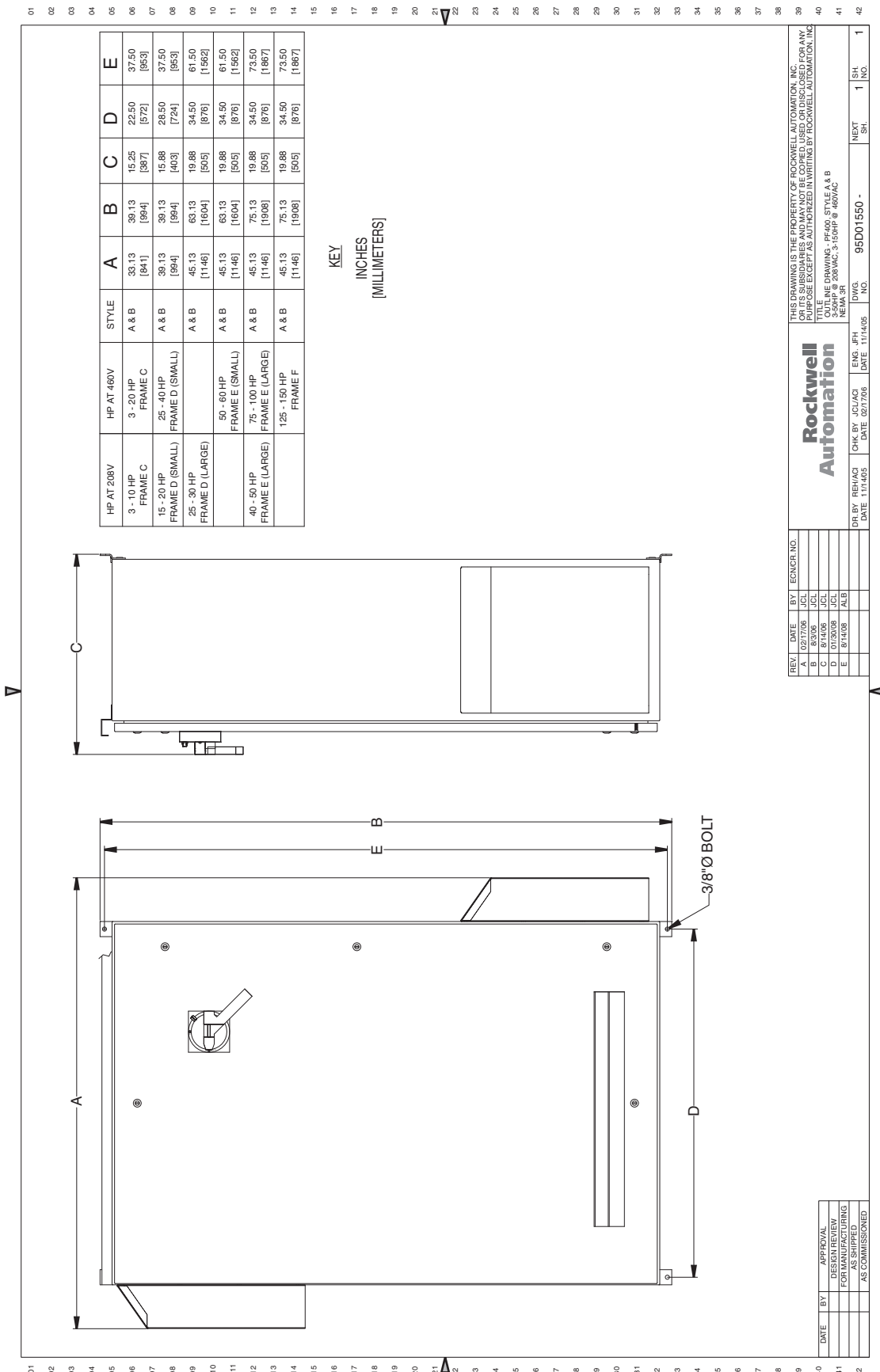

3 Contactor Full Feature Bypass with Disconnect Package (Style B/N)

This chapter describes the features and operation for the 3 Contactor Full Feature Bypass with Disconnect Package (Style B/N).

Topic	Page
Hardware Overview	87
Electrical Installation	92
Operating Modes	96
Parameter Defaults (Style B/N)	97
Drawing Index	98
Schematic Drawings	101
Interconnect Drawings	117
Layout Drawings	122
Outline Drawings	159

Style Explanation

- Style B = Fused Disconnect
- Style N = Circuit Breaker

Hardware Overview

The 3 Contactor Full Feature Bypass with Disconnect Package (Style B/N) allows the motor to be manually transferred from drive output to the AC line, or from the AC line to the drive, while the motor is at zero speed. The contactor bypass is electrically interlocked. A means for disconnecting input power via a door interlocked fuse disconnect switch is standard. In addition, this package is supplied with a bypass control interface, which provides status indication and, allows for remote activation of the bypass circuit.

Main Disconnect Switch (DS1)

An Allen-Bradley® Bulletin 194R™ fused disconnect switch with lockable rotary-mounted operator handle is provided. The disconnect switch is designed to meet disconnect switch requirements for branch circuit protection. The door-mounted handle accepts up to three padlocks.

Main Circuit Breakers (CB1)

A circuit breaker with lockable rotary-mounted operator handle is provided. It is important to note that the circuit breaker serves as a disconnect only. Suitable branch circuit protection, such as fuses, need to be provided upstream of the circuit breaker. The door-mounted handle accepts up to three padlocks.

Main Fuses (FU1-FU3)



ATTENTION: Most codes require that upstream branch circuit protection be provided to help protect input power wiring. Install the fuses recommended in [Table 5](#). Do not exceed the fuse ratings. Failure to observe this precaution could result in damage to, or destruction of, the equipment.

Input line branch circuit protection fuses must be used to help protect the input power lines. If input fuses are not provided with your drive, the recommended fuse values are shown in [Table 5](#). The input fuse ratings that are listed in [Table 5](#) are applicable for one drive per branch circuit. No other load may be applied to that fused circuit.

The recommended fuse type for all PowerFlex® Drives for Fan and Pump Applications is UL Class J, 600V.

Table 5 - Fuse Recommendations

Drive Rating			Fuse Rating
Input Voltage	kW	Hp	Amps
208V AC – 3 Phase	2.2	3.0	20
	3.7	5.0	20
	5.5	7.5	35
	7.5	10	40
	11	15	80
	15	20	100
	18.5	25	125
	22	30	150
	30	40	200
	37	50	250
460V AC – 3 Phase	2.2	3.0	10
	4.0	5.0	15
	5.5	7.5	20
	7.5	10	20
	11	15	35
	15	20	35
	18.5	25	60
	22	30	70
	30	40	80
	37	50	100
	45	60	150
	55	75	175
	75	100	200
	90	125	250
	110	150	350
	132	200	400
160	250	500	
200	300	600	
250	350	700	

Contactors (DIC, DOC, BC)

Allen-Bradley Bulletin 100 Contactors are provided for all ratings. The contactors function as follows:

1. Drive-input contactor (DIC) opens and closes input to the drive.
2. Drive-output contactor (DOC) opens and closes the connection between the drive and the motor.
3. Bypass contactor (BC) opens and closes the connection to line-start the motor.

Motor Overload Relay (OL)

The motor overload relay is set at the factory to 100% of the drive output current. In many cases, this setting matches the motor full load amps (FLA). However, before starting the drive, you should check the setting on the motor overload relay to assure that it is set properly for your motor.

- For motors with a service factor less than 1.15, set the motor overload relays to 0.9x motor FLA.
- For motors with a service factor equal to, or greater than 1.15, set the motor overload relay to the motor FLA.

Figure 66 - Setting Motor Overload

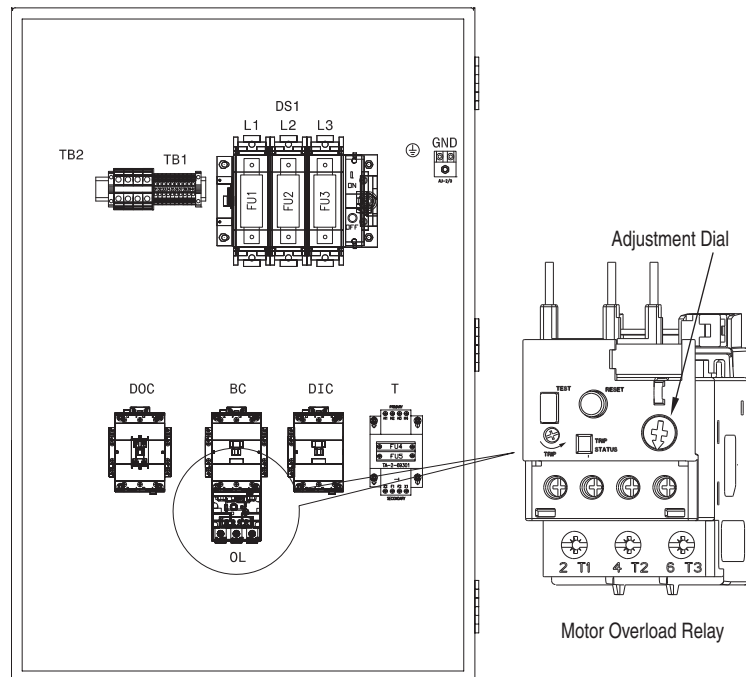

Table 6 - Overload Ratings

Drive Rating			Overload Rating	
Input Voltage	kW	Hp	Trip Class	Adjustment Rating (Amps)
208V AC – 3 Phase	2.2	3.0	20	3.2...16
	3.7	5.0	20	5.4...27
	5.5	7.5	20	9...45
	7.5	10	20	9...45
	11	15	20	18...90
	15	20	20	18...90
	18.5	25	20	18...90
	22	30	20	40...200
	30	40	20	40...200
460V AC – 3 Phase	37	50	20	40...200
	2.2	3.0	20	3.2...16
	4.0	5.0	20	3.2...16
	5.5	7.5	20	3.2...16
	7.5	10	20	5.4...27
	11	15	20	9...45
	15	20	20	9...45
	18.5	25	20	9...45
	22	30	20	9...45
	30	40	20	18...90
	37	50	20	18...90
	45	60	20	18...90
	55	75	20	40...200
	75	100	20	40...200
	90	125	20	40...200
	110	150	20	40...200
	132	200	20	100...500
160	250	20	100...500	
200	300	20	100...500	
250	350	20	100...500	

Control Transformer (T1)

115V AC control power is obtained via a supplied control power transformer. The control transformer is fused on the primary.

Bypass Control Interface (CP1)

The operator interface on the bypass option box shows the following status indicators:

- Ready (green) - On when power is applied to the drive-bypass unit.
- Interlock Open (amber) - On when the customer interlock or Aux Fault is de-energized.
- Bypass Run (green) - On when the bypass contactor (BC) is energized.
- Bypass Trip (red) - On when a bypass fault condition exists (for example, bypass motor overload has tripped).
- Purge (amber) - On when the purge condition is active.
- Drive Output Enable (Green) - On when the drive output contactor (DOC) is energized.

In addition, the Bypass Control Interface contains two selector switches. Selector Switch 1 (SS1) determines the state of the DIC, DOC, and BC contactors. Selector Switch 2 (SS2) determines the source of control logic.

Figure 67 - Bypass Control Interface

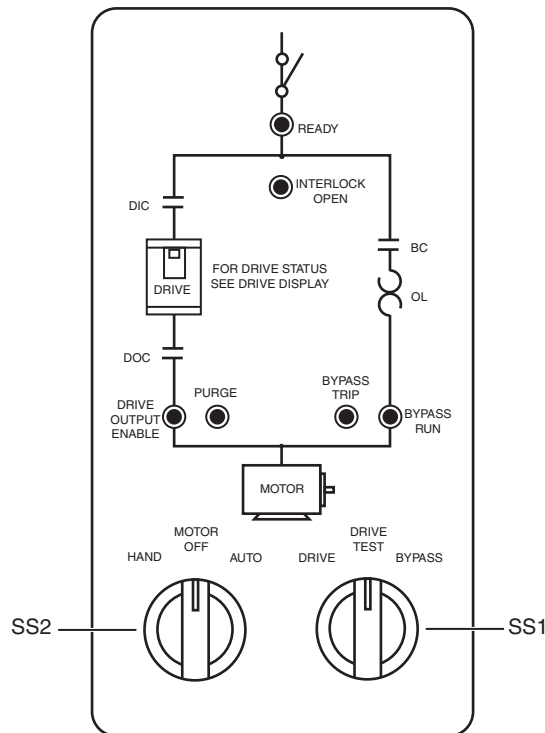

Electrical Installation

Input Power Wiring

Use 75 °C rated copper conductors only for customer power wiring.

See the PowerFlex 400 User Manual, publication [22C-UM001](#) for additional detailed information about input power wiring recommendations and selection.



ATTENTION: Protect the contents of the options cabinet from metal chips and other debris while drilling the conduit openings. Failure to observe this precaution could result in damage to, or destruction of, the equipment.



ATTENTION: Do not route signal and control wiring with power wiring in the same conduit. This can cause interference with drive operation. Failure to observe this precaution could result in damage to, or destruction of, the equipment.

To connect AC input power to the drive package:

- ❑ 1. Select the proper wire size according to NEC and all applicable local codes and standards. You must punch openings in the Option Cabinet of the desired conduit size, following NEC, and all applicable local codes and standards. Power terminal block specifications are listed in [Table 7](#).
- ❑ 2. Connect the three-phase AC input power leads (three-wire VAC) to the appropriate terminals. Connect the AC input power leads to terminals L1, L2, L3 on the fused disconnect switch.
- ❑ 3. Tighten the AC input terminal power terminals to the proper torque according to drive type as shown in [Table 7](#).

Table 7 - AC Input Power Terminal Block Specification

Volts AC	kW	Hp	Maximum Wire Size ⁽¹⁾	Minimum Wire Size	Recommended Torque
208V	2.2...3.7	3.0...5.0	8.4 mm ² (8 AWG)	2.5 mm ² (14 AWG)	4.0 N•m (35 lb•in)
	5.5...7.5	7.5...10	16.0 mm ² (4 AWG)	2.5 mm ² (14 AWG)	4.0 N•m (35 lb•in)
	11...15	15...20	33.6 mm ² (2 AWG)	2.5 mm ² (14 AWG)	17.5 N•m (155 lb•in)
	18.5...30	25...40	250 MCM	10.0 mm ² (6 AWG)	31.1 N•m (275 lb•in)
	37	50	350 MCM	35.0 mm ² (1/0 AWG)	31.1 N•m (275 lb•in)
460V	2.2...7.5	3.0...10	8.4 mm ² (8 AWG)	2.5 mm ² (14 AWG)	4.0 N•m (35 lb•in)
	11...18.5	15...25	16.0 mm ² (4 AWG)	2.5 mm ² (14 AWG)	4.0 N•m (35 lb•in)
	22...37	30...50	33.6 mm ² (2 AWG)	2.5 mm ² (14 AWG)	17.5 N•m (155 lb•in)
	45...75	60...100	250 MCM	10.0 mm ² (6 AWG)	31.1 N•m (275 lb•in)
	90...110	125...150	(2) 350 MCM	(2) 10.0 mm ² (6 AWG)	31.1 N•m (275 lb•in)
	132	200	(2) 350 MCM	(2) 35.0 mm ² (1/0 AWG)	31.1 N•m (275 lb•in)
	160...200	250...300	(2) 350 MCM	(2) 70.0 mm ² (3/0 AWG)	31.1 N•m (275 lb•in)
	250	350	(2) 400 MCM	(2) 70.0 mm ² (3/0 AWG)	31.1 N•m (275 lb•in)

(1) Maximum/minimum sizes that the terminal block will accept - these are not recommendations. If national or local codes require sizes outside the range, lugs may be used.

Output Power Wiring

See the PowerFlex 400 User Manual, publication [22C-UM001](#) for additional detailed information about output power wiring recommendations and selection.



ATTENTION: Unused wires in conduit must be grounded at both ends to avoid a possible shock hazard that is caused by induced voltages. Also, if a drive sharing a conduit is being serviced or installed, all drives using this conduit should be disabled to eliminate the possible shock hazard from cross-coupled motor leads. Failure to observe these precautions could result in bodily injury.



ATTENTION: Do not route signal and control wiring with power wiring in the same conduit. This can cause interference with drive operation. Failure to observe this precaution could result in damage to, or destruction of, the equipment.

To connect AC output power wiring from the drive to the motor:

- ❑ 1. Wire the three-phase AC output power motor leads by routing them according to the drive option type. You must punch openings in the option cabinet of the desired conduit size, following NEC, and all applicable local codes and standards. Output power terminal block specifications are listed in [Table 8](#).

Do not route more than three sets of motor leads through a conduit. This will minimize cross-talk that could reduce the effectiveness of noise reduction methods. If more than three drive/motor connections per conduit are required, shielded cable must be used. If possible, each conduit should contain only one set of motor leads.

- ❑ 2. Connect the three-phase AC output power motor leads to terminals T1, T2, T3 on the output power terminal block (TB2) located inside the option cabinet.
- ❑ 3. Tighten the three-phase AC output power terminals to the proper torque according to drive type as shown in [Table 8](#).

Table 8 - Output Power Terminal Block Specification

Volts AC	kW	Hp	Maximum Wire Size ⁽¹⁾	Minimum Wire Size	Recommended Torque
208V	2.2...5.5	3.0...7.5	8.4 mm ² (8 AWG)	0.5 mm ² (22 AWG)	1.5 N·m (13 lb·in)
	7.5...15	10...20	16.0 mm ² (4 AWG)	2.5 mm ² (14 AWG)	2.3 N·m (20 lb·in)
	18.5...22	25...30	35.0 mm ² (1/0 AWG)	2.5 mm ² (14 AWG)	2.5 N·m (22 lb·in)
	30...37	40...50	350 MCM	10.0 mm ² (6 AWG)	31.1 N·m (275 lb·in)
460V	2.2...5.5	3.0...7.5	8.4 mm ² (8 AWG)	0.5 mm ² (22 AWG)	1.5 N·m (13 lb·in)
	7.5...22	10...30	16.0 mm ² (4 AWG)	2.5 mm ² (14 AWG)	2.3 N·m (20 lb·in)
	30...55	40...75	35.0 mm ² (1/0 AWG)	2.5 mm ² (14 AWG)	2.5 N·m (22 lb·in)
	75	100	350 MCM	10.0 mm ² (6 AWG)	31.1 N·m (275 lb·in)
	90...110	125...150	350 MCM	10.0 mm ² (6 AWG)	31.1 N·m (275 lb·in)
	132...160	200...250	300 MCM	107.2 mm ² (4/0 AWG)	29.4 N·m (260 lb·in)
	200...250	300...350	500 MCM	300 MCM	40.0 N·m (354 lb·in)

(1) Maximum/minimum sizes that the terminal block will accept - these are not recommendations. If national or local codes require sizes outside the range, lugs may be used.

Control and Signal Wiring

See the PowerFlex 400 User Manual, publication [22C-UM001](#) for additional detailed information about control and signal wiring.

The Signal Terminal Block (TB1 Terminals 1...20 and R1...R6) on the drive Main Control Board and Control Terminal Block (TB1 Terminals 31...40) located inside the Option Cabinet provide terminals for interfacing customer supplied control inputs and outputs. All analog and discrete control wiring will be made at these terminals. Typical customer control and signal wiring are shown on the Interconnect drawings, [Figure 84](#) on page [117](#) and [Figure 87](#) on page [120](#).

To connect control and signal wiring to the drive package:

- ❑ 1. Wire the control and signal leads by routing them according to the drive option type. You must punch openings in the option cabinet of the desired conduit size, following NEC, and all applicable local codes and standards. Control and signal terminal block specifications are listed in [Table 9](#).

Control and signal wires should be separated from power wires by at least 0.3 meters (1 foot).

- ❑ 2. Connect the analog and relay output signal wiring to terminals 1...20 and R1...R6 on the drive Main Control Board.
- ❑ 3. Connect the control wiring listed below to terminals 31...40 located inside the Option Cabinet.
 - Interlock
 - Freeze/Fire Stats
 - Autostart
 - Bypass
 - Purge
 - Bypass Running
- ❑ 4. Tighten the control and signal terminals to the proper torque according to drive type as shown in [Table 9](#).

Table 9 - Control and Signal Terminal Block Specifications

Voltage Rating	Terminals	Location	Maximum Wire Size ⁽¹⁾	Minimum Wire Size	Torque
208...460V AC	1...20, R1...R6	Main Control Board	1.3 mm ² (16 AWG)	0.13 mm ² (26 AWG)	0.5-0.8 N•m (4.4...7 lb•in)
	31...40	Option Cabinet	4.0 mm ² (10 AWG)	0.5 mm ² (22 AWG)	0.6 N•m (5.0 lb•in)

(1) Maximum/minimum sizes that the terminal block will accept - these are not recommendations.

Customer Connections

The 3 Contactor Full Feature Bypass with Disconnect Package is designed to accommodate the following customer supplied contacts. Contacts should be rated for 120V AC.

Interlock

The “Interlock” input functions as an Enable input when operating in either Drive or Bypass mode. Opening of the “Interlock” input (T31-T32) will prevent the drive/motor from running. T31-T32 are shipped jumpered together (with a jumper wire) from the factory. If it is desirable to use the “Interlock” input, this jumper wire can be removed and appropriate customer contacts wired in. If a valid “Autostart” or “Bypass” contact is present, the drive/motor will immediately run upon the closing of the “Interlock” input.

Freeze/Fire Stat

The “Freeze/Fire Stat” input functions as a system fault input when operating in either Drive or Bypass mode. Opening of the “Freeze/Fire Stat” input (T31-T33) will prevent the drive/motor from running. T31-T33 are shipped jumpered together (with a jumper wire) from the factory. If it is desirable to use the “Freeze/Fire Stat” input, the jumper wire can be removed and appropriate customer contacts wired in. If the “Freeze/Fire Stat” input opens while operating in Drive mode, the drive will fault and require a manual reset to restart once the input closes. If the “Freeze/Fire Stat” input opens while operating in Bypass mode, the motor will coast to a stop and immediately run upon the reclosing of the input.

Autostart

The “Autostart” input is used to remotely start the drive when SS1 is in the DRIVE position and SS2 is in the AUTO position. A closed input to terminals 34-35 will start the drive.

Bypass

The “Bypass” input is used to remotely start the motor across the 3-phase AC line when SS1 is in the BYPASS position and SS2 is in the AUTO position. A closed input to terminals 34-36 will start the motor.

See [Figure 67](#) on page [91](#) for details on selector switch location.

Purge

A “Purge” input can be wired to terminals 37-38. When this input is closed, the motor will run at the Purge Frequency, which is defined by Parameter A141 [Purge Frequency], assuming the following conditions exist.

- SS1 is either in the DRIVE or BYPASS position.
- SS2 is either in the HAND or AUTO position if Jumper P1 on the Bypass Control Panel (CP1) is in position A.
- SS2 is in the HAND, MOTOR OFF, or AUTO position if Jumper P1 on the Bypass Control Panel (CP1) is in Position B.
- Interlock wired to terminals 31-32 is closed.
- Freeze/Fire Stat wired to terminals 31-33 is closed.



ATTENTION: A Purge command will take precedence over a Stop command from the Comm Port/Network. Insure that another stop method is available if stopping is necessary during a purge.

Bypass Running

The “Bypass Running” contact is normally open. When the Bypass Contactor (BC) is closed, the Bypass Running” contact will also be closed.

Operating Modes

Selector Switch 1 (SS1) and Selector Switch 2 (SS2), on the Bypass Control Panel (CP1), are used to determine the operating state of the 3 Contactor Full Feature Bypass with Disconnect Package. SS1 is used to select motor control:

- DRIVE = Drive keypad/terminal block controls the motor
- DRIVE TEST = Drive is powered but is not controlling the motor
- BYPASS = Motor runs across 3-Phase line

Jumper P2 on the Bypass Control Panel (CP1) allows the drive to be powered while running in bypass. This is accomplished by moving Jumper P2 to position B-C and turning SS1 from BYPASS to DRIVE TEST. If Jumper P2 is in position Allen-Bradley, the drive cannot be powered while running in bypass. SS2 selects the source of the Start, Stop, and Drive Speed Reference as defined in [Table 10](#).

Table 10 - Command and Reference Selection

SS1 ⁽¹⁾ Selection	SS2 ⁽¹⁾ Selection	Start Command ⁽²⁾			Stop Command			Drive Speed Reference ⁽³⁾		
		TB	Keypad	None	TB	Keypad	None	TB	Keypad	None
DRIVE	HAND									
	MOTOR OFF									
	AUTO									
DRIVE TEST	HAND									
	MOTOR OFF									
	AUTO									
BYPASS	HAND	Automatically Starts			Automatically Starts			Motor Runs at Base Speed		
	MOTOR OFF									
	AUTO							Motor Runs at Base Speed		

(1) See [Figure 67](#) on page 91 for details on selector switch location.

(2) When “Auto” is selected, the Start Command is defined by P036 [Start Source]. Factory default is configured for terminal block control. See the PowerFlex 400 User Manual, publication [22C-UM001](#) for other control schemes.

(3) When “Auto” is selected, the Speed Reference is defined by P038 [Speed Reference]. Analog In1 has control by factory default. See the PowerFlex 400 User Manual, publication [22C-UM001](#) for other control schemes.

Parameter Defaults (Style B/N)

Parameter Name	Number	Default
Output Freq	b001	Read Only
Commanded Freq	b002	Read Only
Output Current	b003	Read Only
Output Voltage	b004	Read Only
DC Bus Voltage	b005	Read Only
Drive Status	b006	Read Only
Fault 1 Code	b007	Read Only
Process Display	b008	Read Only
Output Power	b010	Read Only
Elapsed MWh	b011	Read Only
Elapsed Run Time	b012	Read Only
Torque Current	b013	Read Only
Drive Temp	b014	Read Only
Elapsed kWh	b015	Read Only

Motor NP Volts	P031	Drive Rated Volts
Motor NP Hertz	P032	60 Hz
Motor OL Current	P033	Drive Rated Amps
Minimum Freq	P034	0.0 Hz
Maximum Freq	P035	60 Hz
Start Source	P036	6 "2-W Lvl/Enbl" ⁽¹⁾
Stop Mode	P037	1 "Coast, CF"
Speed Reference	P038	2 "Analog In1"
Accel Time 1	P039	20.00 Secs
Decel Time 1	P040	20.00 Secs
Reset To Defaults	P041	0 "Ready/Idle"
Auto Mode	P042	0 "No Function" ⁽¹⁾

Digital In1 Sel	T051	1 "Purge"
Digital In2 Sel	T052	3 "Local"
Digital In3 Sel	T053	10 "Clear Fault"
Digital In4 Sel	T054	4 "Comm Port"
Relay Out1 Sel	T055	0 "Ready/Fault"
Relay Out1 Level	T056	0.0
Relay 1 On Time	T058	0.0 Secs
Relay 1 Off Time	T059	0.0 Secs
Relay Out2 Sel	T060	2 "MotorRunning"
Relay Out2 Level	T061	0.0
Relay 2 On Time	T063	0.0 Secs
Relay 2 Off Time	T064	0.0 Secs
Opto Out Sel	T065	1 "At Frequency"
Opto Out Level	T066	0.0
Opto Out Logic	T068	0 "Normally Open"
Analog In 1 Sel	T069	2 "0-10V"
Analog In 1 Lo	T070	0.0%
Analog In 1 Hi	T071	100.0%
Analog In 1 Loss	T072	0 "Disabled"
Analog In 2 Sel	T073	1 "4-20 mA" ⁽¹⁾
Analog In 2 Lo	T074	0.0%
Analog In 2 Hi	T075	100.0%
Analog In 2 Loss	T076	0 "Disabled"
Sleep-Wake Sel	T077	0 "Disabled"
Sleep Level	T078	10.0%
Sleep Time	T079	0.0 Secs
Wake Level	T080	15.0%
Wake Time	T081	0.0 Secs
Analog Out1 Sel	T082	0 "OutFreq 0-10"
Analog Out1 High	T083	100%
Analog Out1 Setpt	T084	0.0%
Analog Out2 Sel	T085	1 "OutCurr 0-10"
Analog Out2 High	T086	100%
Analog Out2 Setpt	T087	0.0%

Language	C101	1 "English"
Comm Format	C102	0 "RTU 8-N-1"
Comm Data Rate	C103	3 "9600"
Comm Node Addr	C104	100
Comm Loss Action	C105	0 "Fault"
Comm Loss Time	C106	5.0 Secs

Parameter Name	Number	Default
Comm Write Mode	C107	0 "Save"
Purge Frequency	A141	5.0 Hz
Internal Freq	A142	60.00 Hz
Preset Freq 0	A143	0.0 Hz
Preset Freq 1	A144	5.0 Hz
Preset Freq 2	A145	10.0 Hz
Preset Freq 3	A146	20.0 Hz
Accel Time 2	A147	30.00 Secs
Decel Time 2	A148	30.00 Secs
S Curve %	A149	20%
PID Trim Hi	A150	60.0 Hz
PID Trim Lo	A151	0.0 Hz
PID Ref Sel	A152	0 "PID Disabled"
PID Feedback Sel	A153	0 "Analog In 1"
PID Prop Gain	A154	0.01
PID Integ Time	A155	2.0 Secs
PID Diff Rate	A156	0.00
PID Setpoint	A157	0.0%
PID Deadband	A158	0.0%
PID Preload	A159	0.0 Hz
Process Factor	A160	30.0
Auto Rstrt Tries	A163	0
Auto Rstrt Delay	A164	1.0 Secs
Start At PowerUp	A165	1 "Enabled" ⁽¹⁾
Reverse Disable	A166	1 "Rev Disabled"
Flying Start En	A167	1 "Enabled" ⁽¹⁾
PWM Frequency	A168	4.0 kHz
PWM Mode	A169	1 "2-Phase"
Boost Select	A170	4 "45.0, VT"
Start Boost	A171	2.5%
Break Voltage	A172	25.0%
Break Frequency	A173	15.0 Hz
Maximum Voltage	A174	Drive Rated Volts
Slip Hertz @ FLA	A175	2.0 Hz
DC Brake Time	A176	0.0 Secs
DC Brake Level	A177	Drive Rated Amps
DC Brk Time@Strt	A178	0 (Disabled)
Current Limit 1	A179	Drive Rated Amps
Current Limit 2	A180	Drive Rated Amps
Motor OL Select	A181	0 "No Derate"
Drive OL Mode	A182	3 "Both-PWM 1st"
SW Current Trip	A183	0.0 (Disabled)
Load Loss Level	A184	0.0 (Disabled)
Load Loss Time	A185	0 Secs
Stall Fault Time	A186	0 "60 Seconds"
Bus Reg Mode	A187	1 "Enabled"
Skip Frequency 1	A188	0 Hz
Skip Freq Band 1	A189	0.0 Hz
Skip Frequency 2	A190	0 Hz
Skip Freq Band 2	A191	0.0 Hz
Skip Frequency 3	A192	0 Hz
Skip Freq Band 3	A193	0.0 Hz
Compensation	A194	1 "Electrical"
Reset Meters	A195	0 "Ready/Idle"
Testpoint Sel	A196	400
Fault Clear	A197	0 "Ready/Idle"
Program Lock	A198	0 "Unlocked"
Motor NP Poles	A199	4

Relay Out3 Sel	R221	0 "Ready/Fault"
Relay Out3 Level	R222	0.0
Relay Out4 Sel	R224	0 "Ready/Fault"
Relay Out4 Level	R225	0.0
Relay Out5 Sel	R227	0 "Ready/Fault"
Relay Out5 Level	R228	0.0
Relay Out6 Sel	R230	0 "Ready/Fault"
Relay Out6 Level	R231	0.0
Relay Out7 Sel	R233	0 "Ready/Fault"
Relay Out7 Level	R234	0.0
Relay Out8 Sel	R236	0 "Ready/Fault"

Parameter Name	Number	Default
Relay Out8 Level	R237	0.0
Aux Motor Mode	R239	0 "Disabled"
Aux Motor Qty	R240	1 "1 Aux Mtr"
Aux 1 Start Freq	R241	50.0 Hz
Aux 1 Stop Freq	R242	25.0 Hz
Aux 1 Ref Add	R243	0.0%
Aux 2 Start Freq	R244	50.0 Hz
Aux 2 Stop Freq	R245	25.0 Hz
Aux 2 Ref Add	R246	0.0%
Aux 3 Start Freq	R247	50.0 Hz
Aux 3 Stop Freq	R248	25.0 Hz
Aux 3 Ref Add	R249	0.0%
Aux Start Delay	R250	5.0 Secs
Aux Stop Delay	R251	3.0 Secs
Aux Prog Delay	R252	0.50 Secs
Aux AutoSwap Time	R253	0.0 Hr
Aux AutoSwap Lvl	R254	50.0%

Control Source	d301	Read Only
Contrl In Status	d302	Read Only
Comm Status	d303	Read Only
PID Setptn Displ	d304	Read Only
Analog In 1	d305	Read Only
Analog In 2	d306	Read Only
Fault 1 Code	d307	Read Only
Fault 2 Code	d308	Read Only
Fault 3 Code	d309	Read Only
Fault 1 Time-hr	d310	Read Only
Fault 1 Time-min	d311	Read Only
Fault 2 Time-hr	d312	Read Only
Fault 2 Time-min	d313	Read Only
Fault 3 Time-hr	d314	Read Only
Fault 3 Time-min	d315	Read Only
Elapsed Time-hr	d316	Read Only
Elapsed Time-min	d317	Read Only
Output Powr Fctr	d318	Read Only
Testpoint Data	d319	Read Only
Control SW Ver	d320	Read Only
Drive Type	d321	Read Only
Output Speed	d322	Read Only
Output RPM	d323	Read Only
Fault Frequency	d324	Read Only
Fault Current	d325	Read Only
Fault Bus Volts	d326	Read Only
Status @ Fault	d327	Read Only

- (1) The default values of these parameters differ from Factory Defaults. Setting P041 [Reset To Defaults] to 1 "Factory Reset" will change these parameter settings to the defaults listed in the PowerFlex 400 User Manual, publication [22C-UM001](#).



ATTENTION: Parameter A165 [Start At PowerUp] ships from the factory enabled. This feature allows a Run command to automatically cause the drive to resume running at commanded speed after drive input power is restored. Equipment damage and/or personal injury may result if this parameter is used in an inappropriate application. Do not use this function without considering applicable local, national, and international codes, standards, regulations or industry guidelines.

Drawing Index

208V AC – 3 Contactor Full Feature Bypass with Disconnect Package (Style B/N)

Input Voltage	Type	Hp	Input Line Reactor	Drawing				HP	Style									
				SchematicPage	InterconnectPage	LayoutPage	OutlinePage											
208V AC	NEMA/UL Type 1	3	No	98D00705	101	97D00704	117	95D00761	122	95D00719	159	3	B					
		5						95D00762	123	95D00698	160	5						
		7.5						95D00763	124	95D00700	161	7.5						
		10						95D00777	125	95D00701	162	10						
		15						95D00765	127	95D00702	163	15						
		20						95D00778	128	95D00703	164	20						
		25						95D00793	132	95D00720	168	25						
		30						95D00794	133	95D00699	169	30						
		40						95D01371	134	95D01363	170	40						
		50						95D01372	135	95D01364	171	50						
		3						Yes	98D00757	107	97D00755	120		95D01377	136	95D01364	171	3
		5												95D01374	138	95D01366	173	5
		7.5												95D01580	139	95D01552	174	7.5
		10												95D01581	140	95D01552	174	10
		15												95D01582	141	95D01552	174	15
	20	95D01583	142	95D01552	174	20												
	25	95D01569	145	95D01551	175	25												
	30	95D01571	146	95D01551	175	30												
	40	95D02456	147	95D01551	175	40												
	50	95D02496	148	95D01551	175	50												
	3	With or Without	98D01539	111	97D01549	121	95D01558							152	95D01550	176	3	
	5						95D01559							153	95D01550	176	5	
	7.5						95D01560							154	95D01550	176	7.5	
	10						95D02494							155	95D01550	176	10	
	15						95D01559							153	95D01550	176	15	
	20						95D01560	154	95D01550	176	20							
	25						95D01559	153	95D01550	176	25							
	30						95D01560	154	95D01550	176	30							
	40						95D02494	155	95D01550	176	40							
	50						95D01559	153	95D01550	176	50							
3	With or Without						98D01536	115	97D01549	121	95D01558	152	95D01550	176	3			
5											95D01559	153	95D01550	176	5			
7.5											95D01560	154	95D01550	176	7.5			
10											95D02494	155	95D01550	176	10			
15											95D01559	153	95D01550	176	15			
20		95D01560	154	95D01550	176	20												
25		95D01559	153	95D01550	176	25												
30		95D01560	154	95D01550	176	30												
40		95D02494	155	95D01550	176	40												
50		95D01559	153	95D01550	176	50												

460V AC – 3 Contactor Full Feature Bypass with Disconnect Package (Style B/N)

Input Voltage	Type	Hp	Input Line Reactor	Drawing								Hp	Style					
				Schematic	Page	Interconnect	Page	Layout	Page	Outline	Page							
460V AC	NEMA/UL Type 1	3	No									3	B					
		5										5						
		7.5										7.5						
		10										10						
		15										15						
		20										20						
		25										25						
		30										98D00705 101		97D00704 117	95D00763 124	95D00700 161	30	
		40															40	
		50															50	
		60													95D00764 126	95D00702 163	60	
		75															75	
		100													95D00765 127		100	
		125													95D01263 129	95D01265 165	125	
		150															150	
		200												98D01861 103	97D01892 118	95D01863 130	95D01867 166	200
		250															250	
		300												98D01860 105	97D01891 119	95D01865 131	95D01869 167	300
		350															350	
												NEMA/UL Type 12		3	With or Without			
	5	5																
	7.5	7.5																
	10	10																
	15	15																
	20	20																
	25	25																
	30	98D01541 109	97D01549 121	95D01580 139	95D01552 174	30												
	40					40												
	50			95D01581 140		50												
	60					60												
	75			95D01582 141		75												
	100			95D01583 142		100												
	125					125												
	150			95D01584 143		150												

Input Voltage	Type	Hp	Input Line Reactor	Drawing				Hp	Style															
				Schematic	Page	Interconnect	Page			Layout	Page	Outline	Page											
460V AC	NEMA/UL Type 4	3	With or Without	98D01539	111	97D01549	121	95D02443	144	95D01551	175	3	B & N											
		5						5	7.5			10		15	20	25	30	40	50	60	75	100	125	150
		7.5						10	15			20		25	30	40	50	60	75	100	125	150		
		10						15	20			25		30	40	50	60	75	100	125	150			
		15						20	25			30		40	50	60	75	100	125	150				
		20						25	30			40		50	60	75	100	125	150					
		25						30	40			50		60	75	100	125	150						
		30						40	50			60		75	100	125	150							
		40						50	60			75		100	125	150								
		50						60	75			100		125	150									
		60						75	100			125		150										
		75						100	125			150												
		100						125	150															
		125						150																
		150																						
	NEMA/UL Type 3R	With or Without	3	98D01536	115	97D01549	121	95D01558	152	95D01550	176	3												
			5					5	7.5			10		15	20	25	30	40	50	60	75	100	125	150
			7.5					10	15			20		25	30	40	50	60	75	100	125	150		
			10					15	20			25		30	40	50	60	75	100	125	150			
			15					20	25			30		40	50	60	75	100	125	150				
			20					25	30			40		50	60	75	100	125	150					
			25					30	40			50		60	75	100	125	150						
			30					40	50			60		75	100	125	150							
			40					50	60			75		100	125	150								
			50					60	75			100		125	150									
			60					75	100			125		150										
			75					100	125			150												
			100					125	150															
			125					150																
			150																					

Schematic Drawings

Figure 68 - 3.0...50 Hp, 208V AC and 3.0...150 Hp, 460V AC Drives (Sheet 1 of 2) - NEMA/UL Type 1

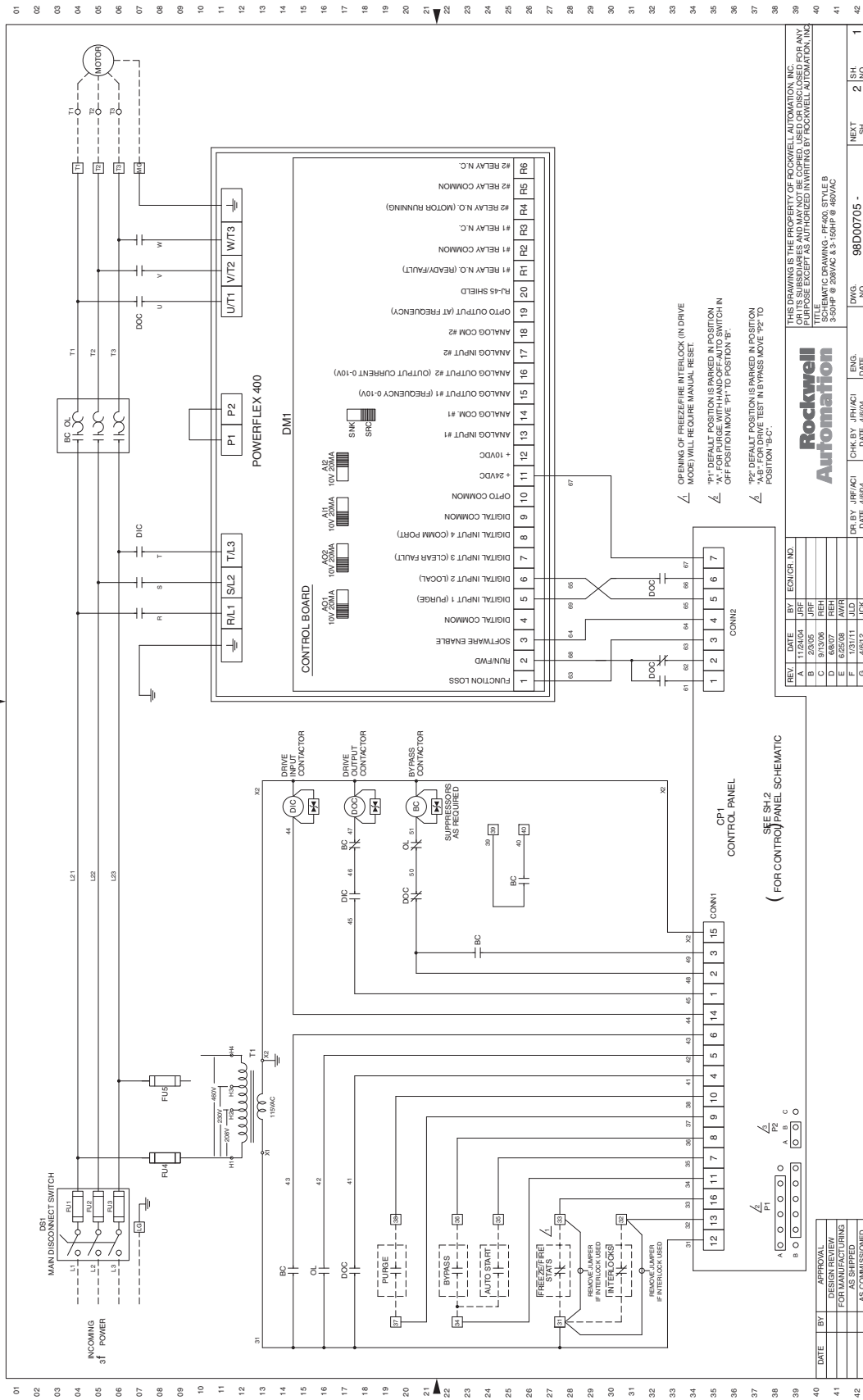
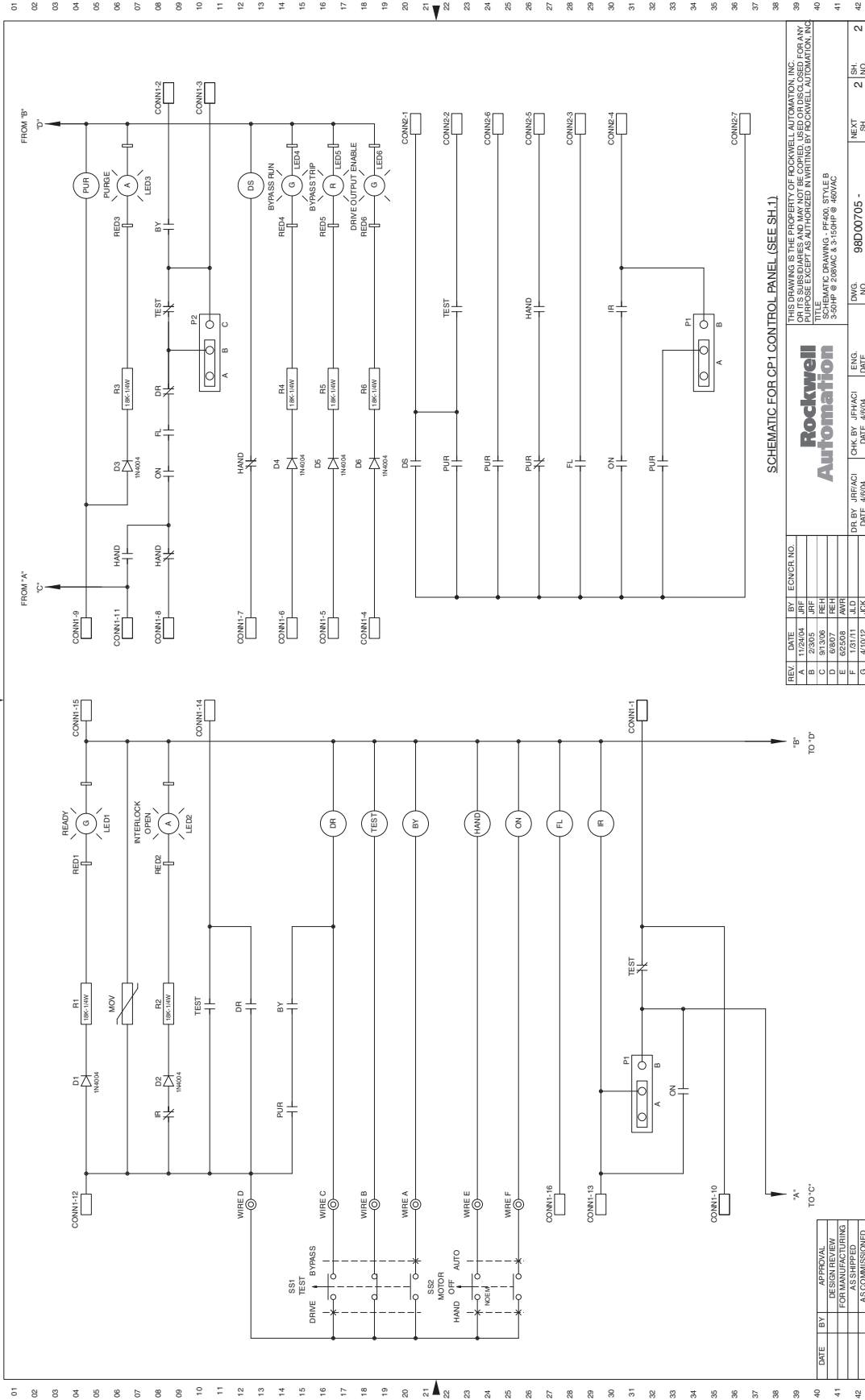

Figure 69 - 3.0...50 Hp, 208V AC and 3.0...150 Hp, 460V AC Drives (Sheet 2 of 2) - NEMA/UL Type 1



SCHEMATIC FOR CP1 CONTROL PANEL (SEE SH.1)

REV	DATE	BY	ENCR NO.
A	1/28/04	JRF	
B	6/23/04	REH	
C	8/13/06	REH	
D	6/8/07	REH	
E	6/25/08	AVR	
F	1/31/11	JED	
G	4/18/12	SC1	

THIS DRAWING IS THE PROPERTY OF ROCKWELL AUTOMATION, INC. FOR ANY PURPOSE EXCEPT AS AUTHORIZED IN WRITING BY ROCKWELL AUTOMATION, INC.

TITLE: **Rockwell Automation**
 3-50HP @ 208VAC & 3-150HP @ 460VAC

DRN BY: JRF/ACI
 DATE: 4/6/04

CHK BY: JPH/ACI
 DATE: 4/6/04

ENG. NO. 98D00705 -
 DWG. NO. 98D00705 -

NEXT SH. 2
 SH. NO. 2

DATE	BY	APPROVAL
		DESIGN REVIEW
		FOR MANUFACTURING
		ASSIGNED
		AS COMMISSIONED

Figure 70 - 200 Hp, 460V AC Drives (Sheet 1 of 2) - NEMA/UL Type 1

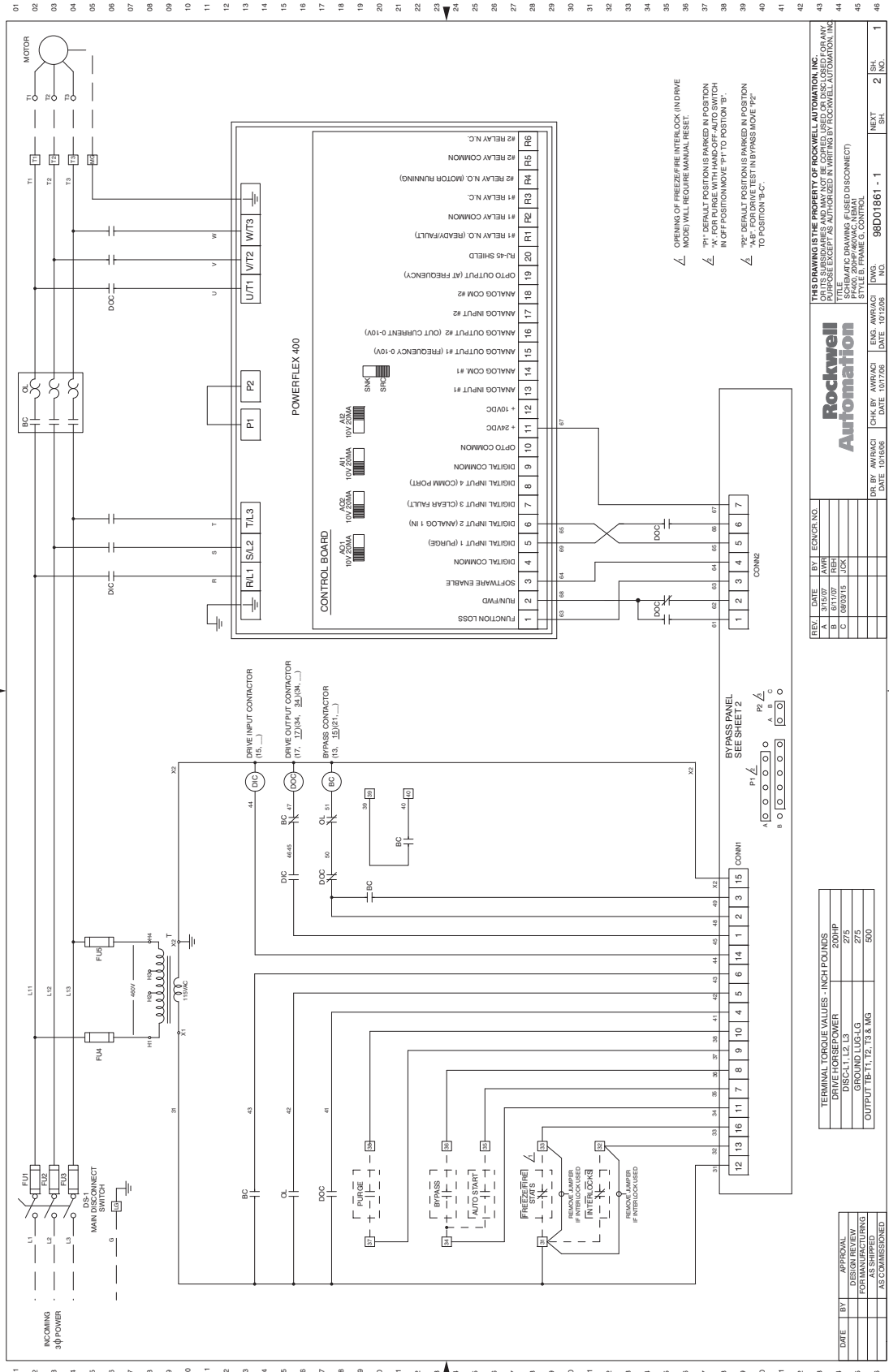

OPENING OF FREEZE/INTERLOCK (IN DRIVE MODE) WILL REQUIRE MANUAL RESET.

"P" - DEFAULT POSITION IS MARKED IN POSITION "A" FOR PURGE WITH HAND-OFF-AUTO SWITCH IN OFF POSITION MOVE P-1 TO POSITION "B".

"B" - DEFAULT POSITION IS MARKED IN POSITION "A" FOR DRIVE TEST IN BYPASS MOVE "P2" TO POSITION "B-C".

REV	DATE	BY	ECNOR. NO.
A	01/03/15	AWA	
B	05/03/15	JCK	
C	05/03/15	JCK	

DATE	BY	APPROVAL	DESIGN REVIEW	PRINTED	AS SHIPPED	AS COMMISSIONED

TERMINAL	TORQUE VALUES - INCH POUNDS
DISC L1, L2, L3	275
GROUND LUG-LG	275
OUTPUT TB-T1, T2, T3 & MG	500

DR BY	AWR/AC	CHK BY	AWR/AC	ENG	AWR/AC	DATE	10/12/06	NO.	98DD1861 - 1	REV	SH	NO.	1

Rockwell Automation	
THIS DRAWING IS THE PROPERTY OF ROCKWELL AUTOMATION, INC. NO PART OF THIS DRAWING IS TO BE REPRODUCED OR TRANSMITTED IN ANY FORM OR BY ANY MEANS, ELECTRONIC OR MECHANICAL, INCLUDING PHOTOCOPYING, RECORDING, OR BY ANY INFORMATION STORAGE AND RETRIEVAL SYSTEM, WITHOUT THE WRITTEN PERMISSION OF ROCKWELL AUTOMATION, INC.	
TITLE: NEMA/UL TYPE 1 200 HP/460V AC DRIVE WITH 3-POLE/4-POLE/5-POLE/6-POLE/7-POLE/8-POLE/9-POLE/10-POLE/11-POLE/12-POLE/13-POLE/14-POLE/15-POLE/16-POLE/17-POLE/18-POLE/19-POLE/20-POLE/21-POLE/22-POLE/23-POLE/24-POLE/25-POLE/26-POLE/27-POLE/28-POLE/29-POLE/30-POLE/31-POLE/32-POLE/33-POLE/34-POLE/35-POLE/36-POLE/37-POLE/38-POLE/39-POLE/40-POLE/41-POLE/42-POLE/43-POLE/44-POLE/45-POLE/46-POLE	

Figure 71 - 200 Hp, 460V AC Drives (Sheet 2 of 2) - NEMA/UL Type 1

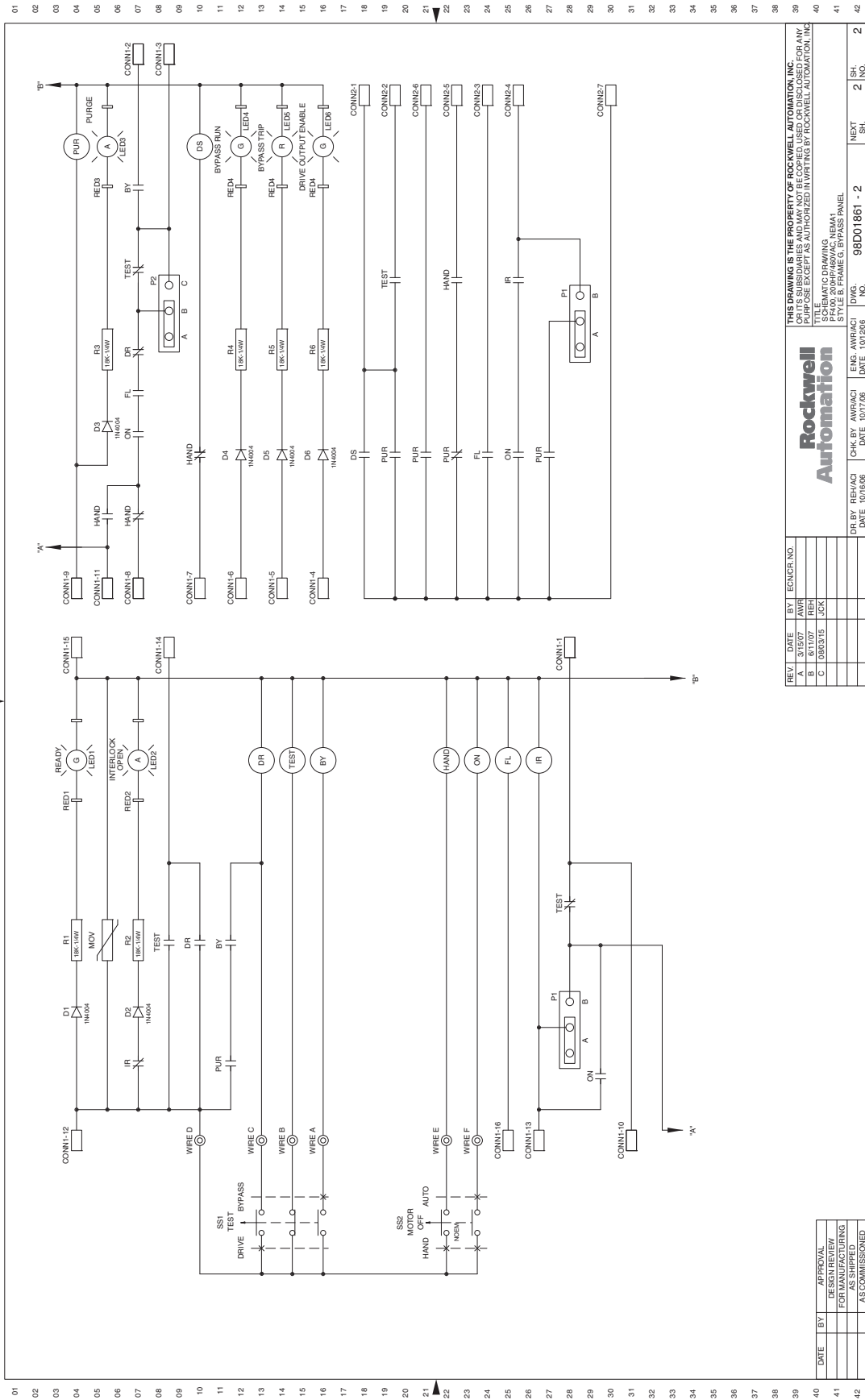

REV.	DATE	BY	ENCR. NO.
A	08/07/15	JCK	
B	08/07/15	JCK	
C	08/03/15	JCK	

DR. BY	REH/AC	DATE	CHK. BY	AWP/ACI	DATE	ENG. AWR/ACI	DATE	DWG. NO.	REV.	SH. NO.
		03/08/08			03/17/08			98D01861 - 2	2	2

DATE	BY	APPROVAL
		DESIGN REVIEW
		FOR MANUFACTURING
		AS COMMISSIONED

THIS DRAWING IS THE PROPERTY OF ROCKWELL AUTOMATION, INC. NO PART OF THIS DRAWING IS TO BE REPRODUCED OR TRANSMITTED IN ANY FORM OR BY ANY MEANS, ELECTRONIC OR MECHANICAL, INCLUDING PHOTOCOPYING, RECORDING, OR BY ANY INFORMATION STORAGE AND RETRIEVAL SYSTEM, WITHOUT THE WRITTEN PERMISSION OF ROCKWELL AUTOMATION, INC.

TITLE: ELECTRIC DRAWING
 PROJECT: 200HP460VAC, NEMA1
 STYLE: B FRAME G BYPASS PANEL

Figure 72 - 250...350 Hp, 460V AC Drives (Sheet 1 of 2) - NEMA/UL Type 1

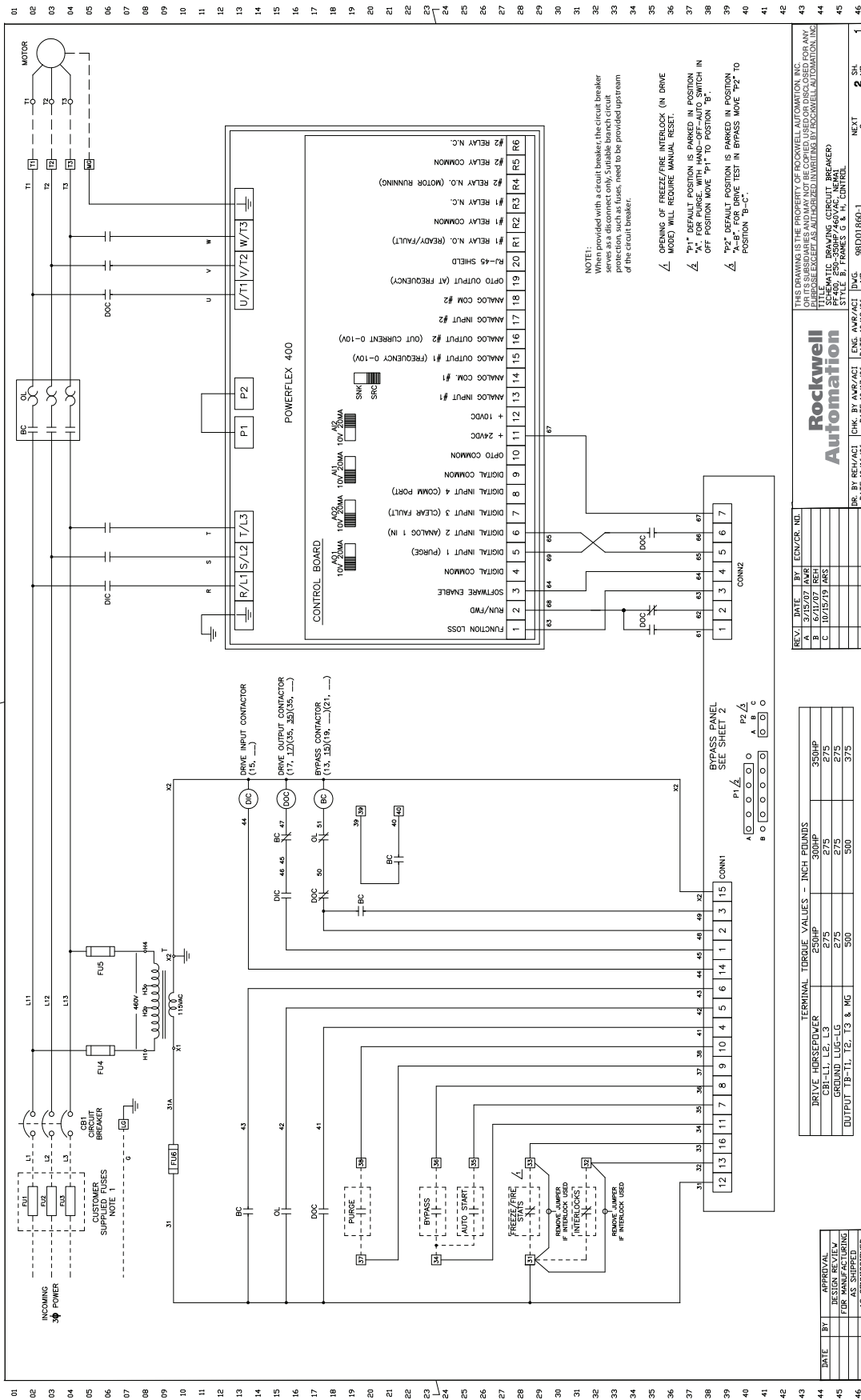
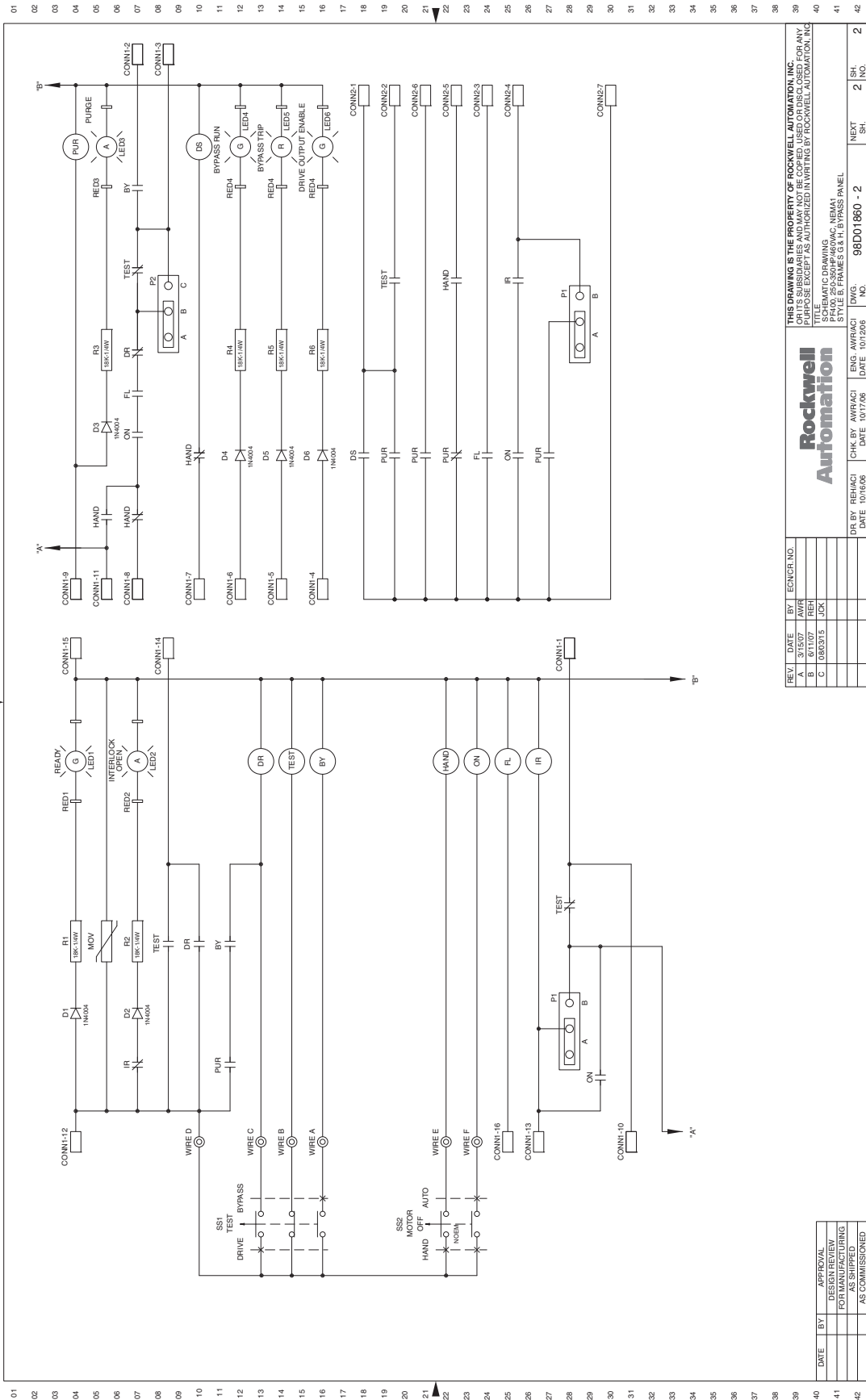

Figure 73 - 250...350 Hp, 460V AC Drives (Sheet 2 of 2) - NEMA/UL Type 1



REV	DATE	BY	ECNCR. NO.
A	8/11/07	REH	
C	08/03/15	JCK	

DATE	BY	APPROVAL
		DESIGN REVIEW
		FOR MANUFACTURING
		AS COMMISSIONED

DS BY	REV(S)	CHK BY	AWR(S)	DATE	DS	AWR(S)	DATE	TEST	DATE	TEST	DATE
				10/16/09			10/12/09				

Rockwell Automation		
THIS DRAWING IS THE PROPERTY OF ROCKWELL AUTOMATION, INC. IT IS TO BE USED FOR ANY PURPOSE EXCEPT AS AUTHORIZED IN WRITING BY ROCKWELL AUTOMATION, INC.		
TITLE: AUTOMATIC DRAWING		
P#400, 250-350HP/460VAC, NEMA1		
STYLE B, FRAMES G & H, BYPASS PANEL		
98D01860 - 2	INSTR.	INSTR.
NET	2	2
BA		

Figure 74 - 3.0...50 Hp, 208V AC and 3.0...100 Hp, 460V AC Drives with Line Reactor (Sheet 1 of 2) - NEMA/UL Type 1

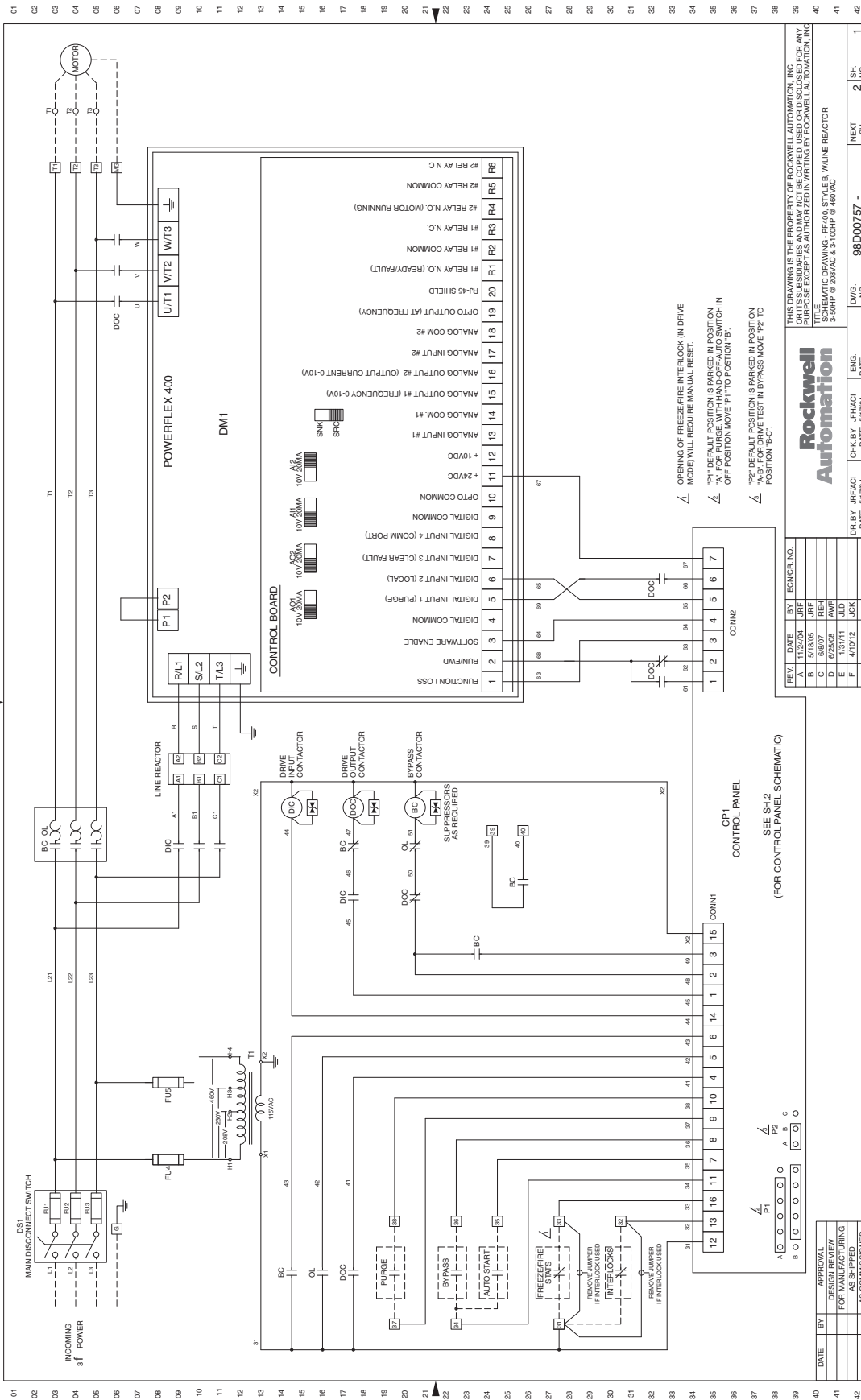

REV.	DATE	BY	ECNCR. NO.
A	11/24/04	JRF	
B	5/18/05	JRF	
C	8/25/08	JAVR	
D	1/31/11	JLD	
E	4/10/12	JCK	
F	4/10/12	JCK	

DATE	APPROVAL	DESIGN REVIEW	FOR MANUFACTURING	AS SHIPPED	AS COMMISSIONED

DR. BY	JRF/AC1	DATE	5/17/04	ENG.	JPH/AC1	DATE	5/17/04	DWG. NO.	98D00757 -	NEXT SH.	2	INC.	1
--------	---------	------	---------	------	---------	------	---------	----------	------------	----------	---	------	---

THIS DRAWING IS THE PROPERTY OF ROCKWELL AUTOMATION, INC. OR ITS SUBSIDIARIES AND MAY NOT BE COPIED, USED, OR DISCLOSED FOR ANY PURPOSES WITHOUT THE WRITTEN PERMISSION OF ROCKWELL AUTOMATION, INC.

DRIVE TEST POSITION IS PARKED IN POSITION 'P2' TO POSITION 'P1'.

*P1: DEFAULT POSITION IS PARKED IN POSITION 'P2' TO POSITION 'P1'.

*P2: DEFAULT POSITION IS PARKED IN POSITION 'P1' TO POSITION 'P2'.

*A.B.T. FOR DRIVE TEST IN BYPASS MOVE 'P2' TO POSITION 'P1'.

OPENING OF FREEZURE INTERLOCK (IN DRIVE MODE) WILL REQUIRE MANUAL RESET.

FOR CONTROL PANEL SCHEMATIC SEE SH.2

Figure 75 - 3.0...50 Hp, 208V AC and 3.0...100 Hp, 460V AC Drives with Line Reactor (Sheet 2 of 2) - NEMA/UL Type 1

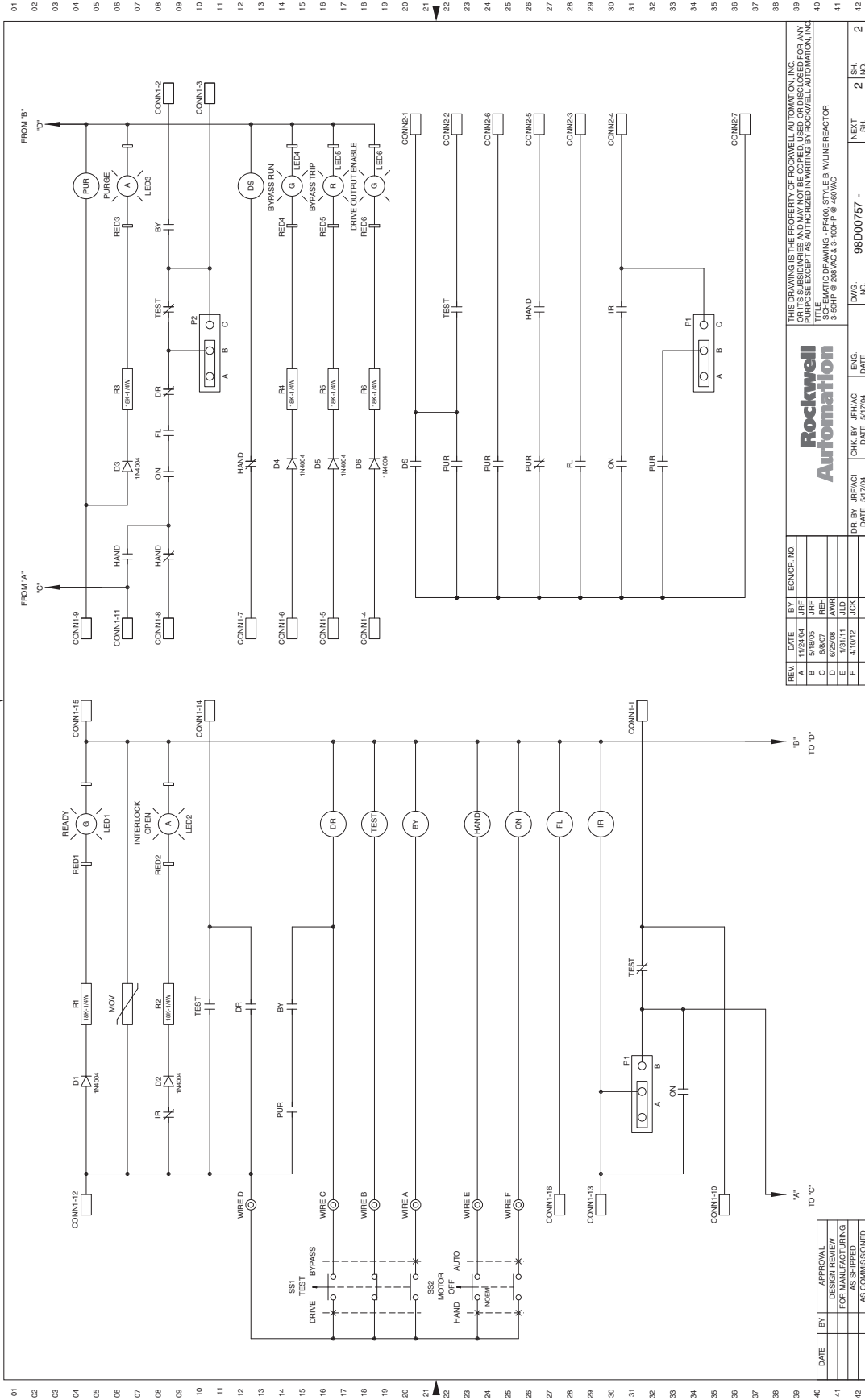

REV.	DATE	BY	ENCR. NO.
A	1/28/04	JFE	
B	6/25/08	REH	
C	6/25/08	AWR	
D	6/25/08	AWR	
E	1/31/11	JLD	
F	4/10/12	JCK	

DR. BY	JFH/ACI	CHK. BY	JFH/ACI	ENG. DATE	8/7/04	ENG. DATE	8/7/04	DWG. NO.	98D00757	NEXT SH.	2	SH. NO.	2
--------	---------	---------	---------	-----------	--------	-----------	--------	----------	----------	----------	---	---------	---

THIS DRAWING IS THE PROPERTY OF ROCKWELL AUTOMATION, INC. NO PARTS OR INFORMATION CONTAINED HEREIN ARE TO BE REPRODUCED OR TRANSMITTED IN ANY FORM OR BY ANY MEANS, ELECTRONIC OR MECHANICAL, INCLUDING PHOTOCOPYING, RECORDING, OR BY ANY INFORMATION STORAGE AND RETRIEVAL SYSTEM, WITHOUT THE WRITTEN PERMISSION OF ROCKWELL AUTOMATION, INC.

TITLE: 3-50HP @ 208VAC & 3-100HP @ 460VAC
 FILE: 23C-IN001D-EN-P (Style B/N) LINE REACTOR

Figure 76 - 3.0...50 Hp, 208V AC and 3.0...150 Hp, 460V AC Drives (Sheet 1 of 2) - NEMA/UL Type 12

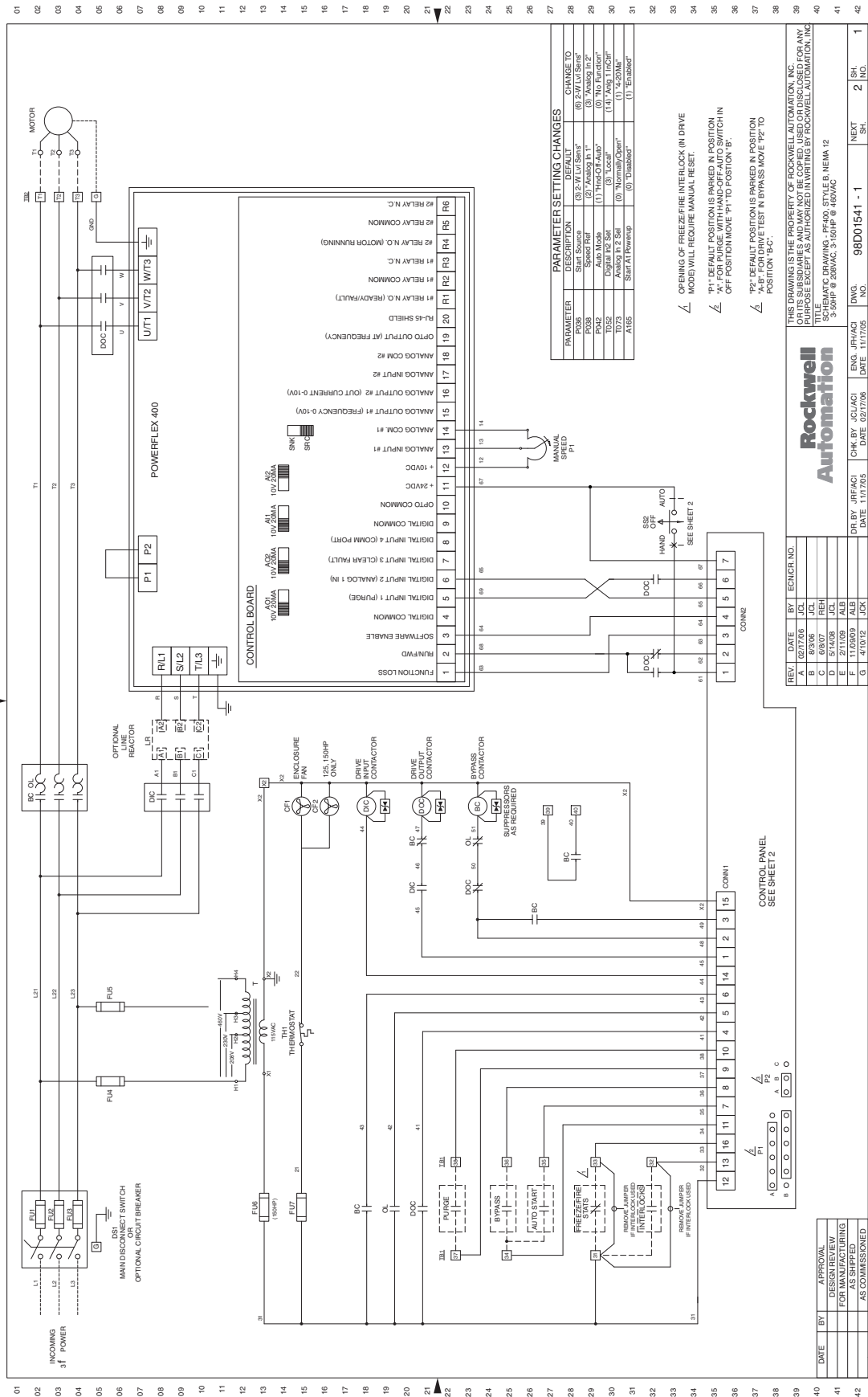

Figure 77 - 3.0...50 Hp, 208V AC and 3.0...150 Hp, 460V AC Drives (Sheet 2 of 2) - NEMA/UL Type 12

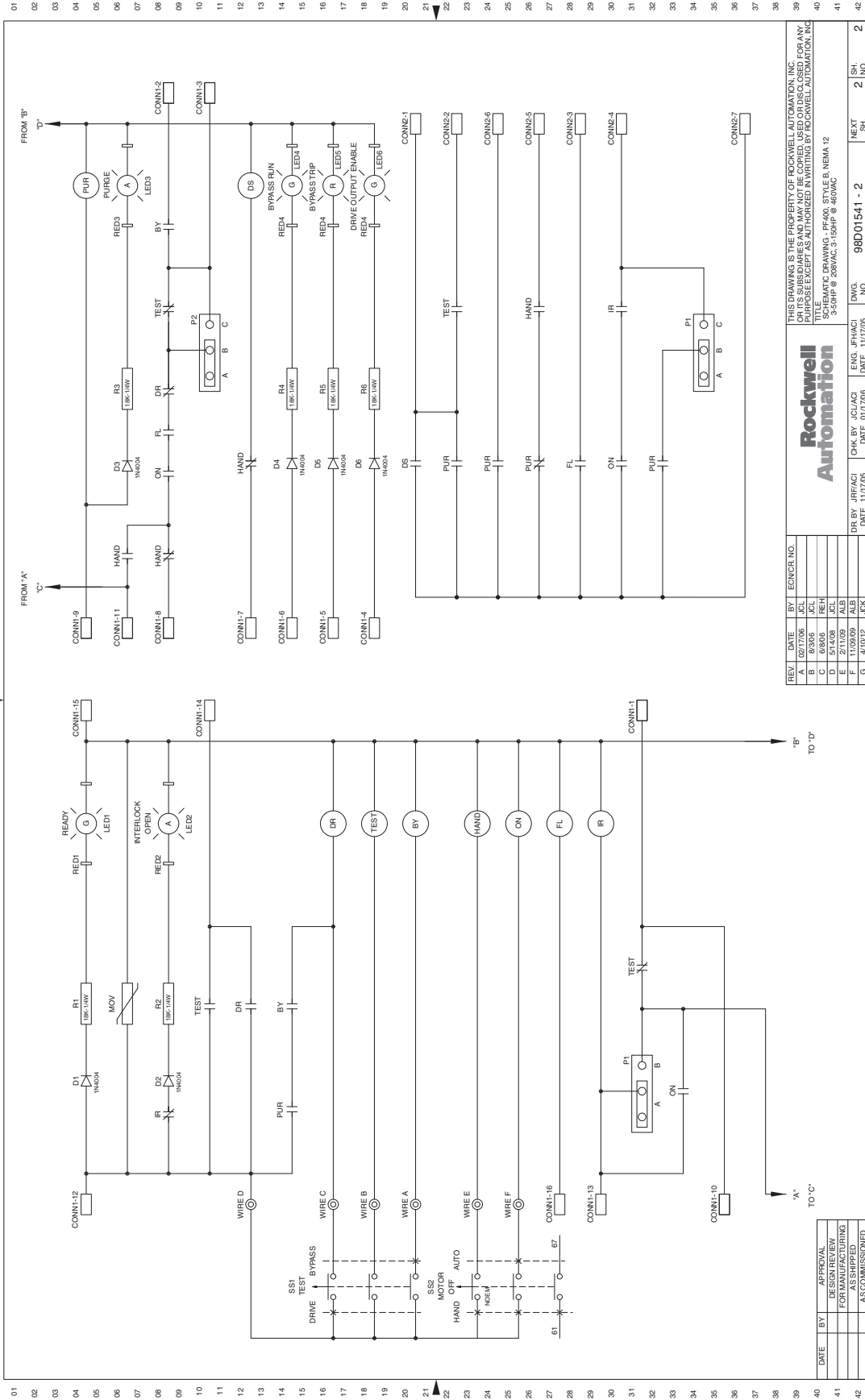

Figure 78 - 3.0...50 Hp, 208V AC and 3.0...100 Hp, 460V AC Drives (Sheet 1 of 2) - NEMA/UL Type 4

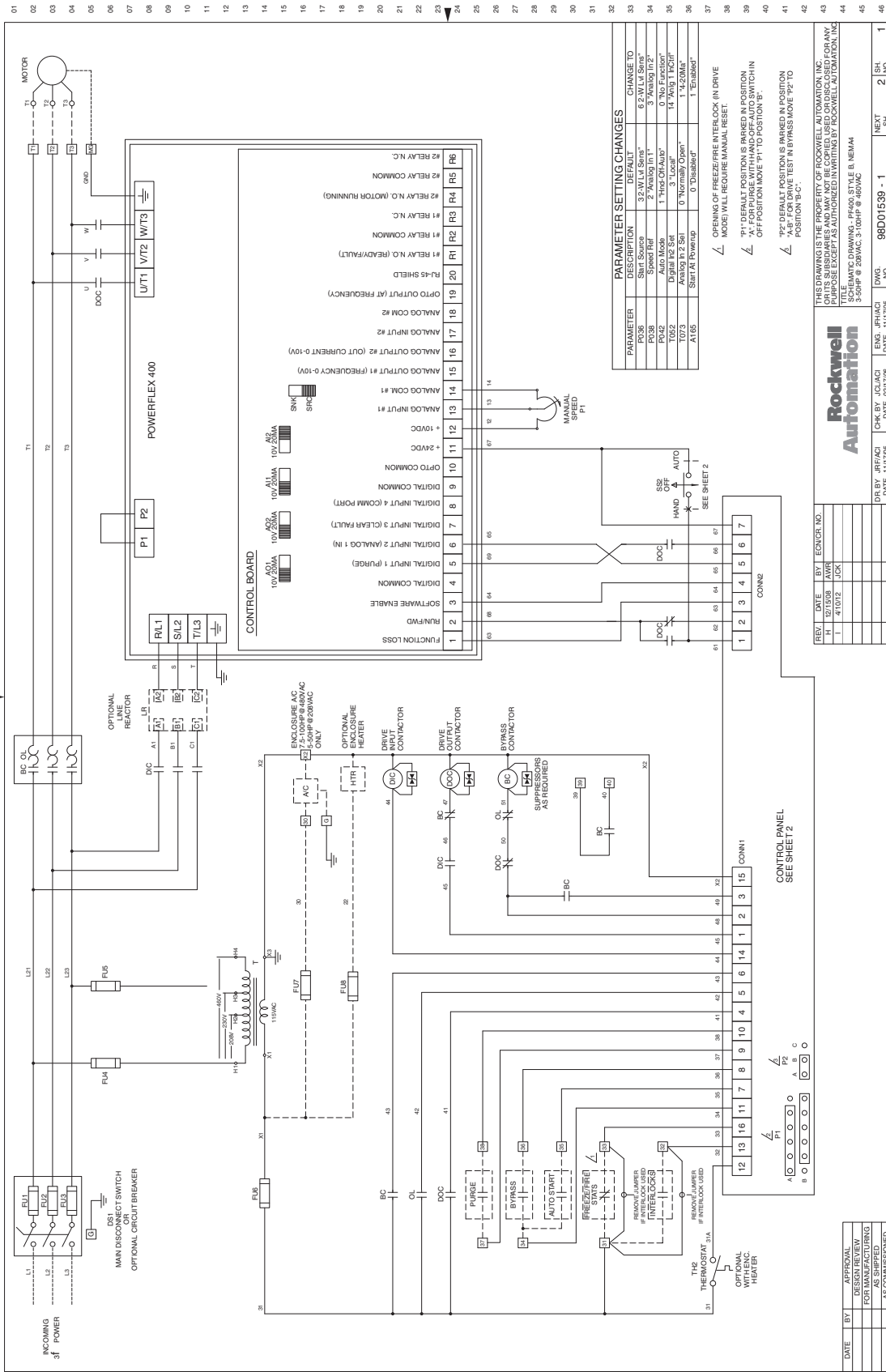
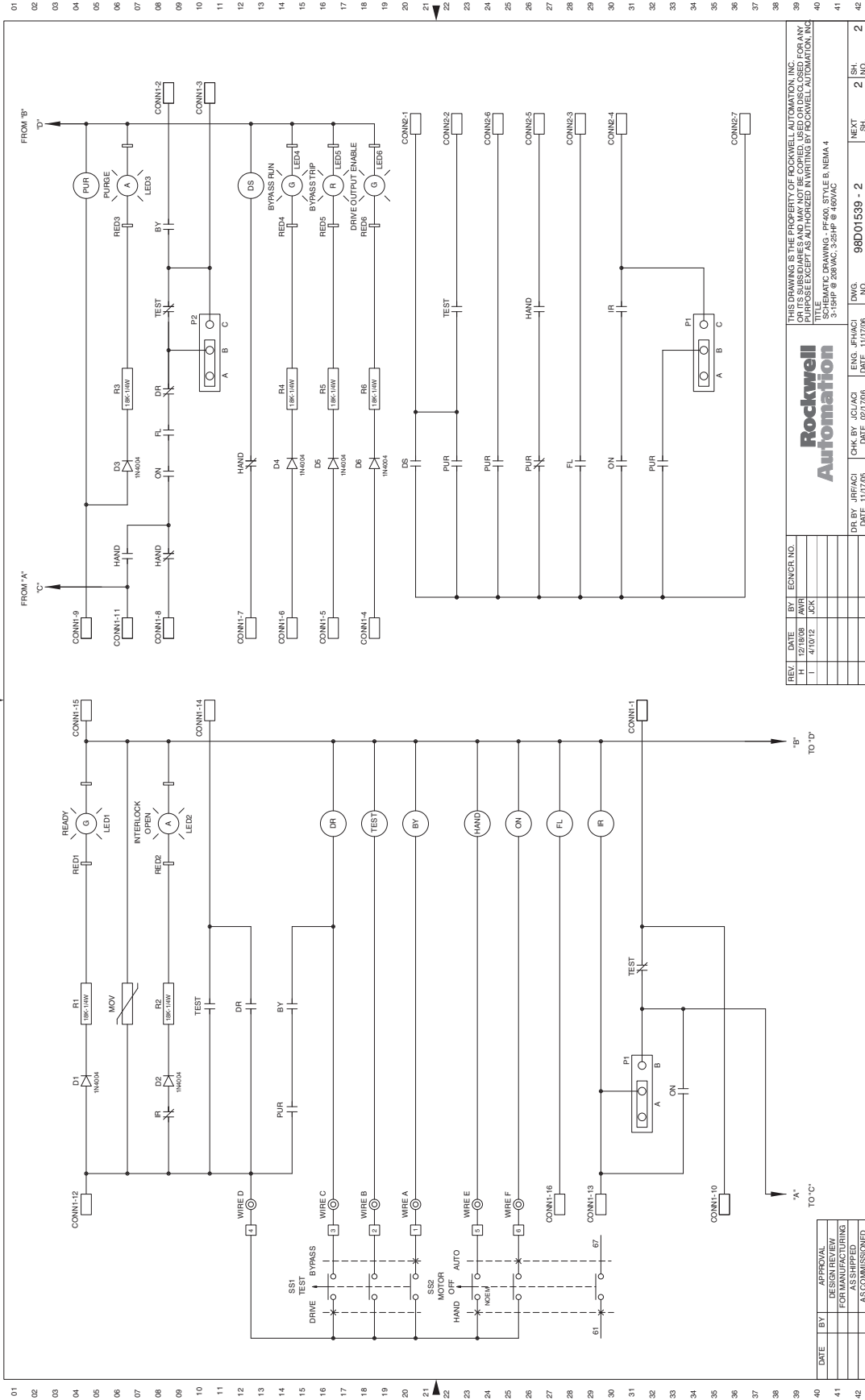

Figure 79 - 3.0...30 Hp, 208V AC and 3.0...40 Hp, 460V AC Drives (Sheet 2 of 2) - NEMA/UL Type 4



REV	DATE	BY	ENCROR NO.
H	12/18/08	AWH	
T	4/10/12	GAN	

DRN BY	JRH/ACI	CHK BY	JCL/ACI	DATE	11/17/08	13/RE	11/17/08	ENG.	JPH/ACI	DWG.	NO.	98D01539 - 2	NEXT	SH.	NO.

THIS DRAWING IS THE PROPERTY OF ROCKWELL AUTOMATION, INC. IT IS TO BE USED FOR THE SPECIFIC PROJECT AND NOT BE REPRODUCED OR COPIED IN ANY MANNER WITHOUT THE WRITTEN PERMISSION OF ROCKWELL AUTOMATION, INC.

TITLE: 3.0...40 HP, 208V AC and 3.0...40 HP, 460V AC Drives (Sheet 2 of 2) - NEMA/UL Type 4

DATE: 11/17/08

ENG: JPH/ACI

DWG. NO: 98D01539 - 2

DATE: 11/17/08

CHK BY: JCL/ACI

DRN BY: JRH/ACI

DATE: 11/17/08

13/RE: 11/17/08

11/17/08

Figure 80 - 125...150 Hp, 460V AC Drives (Sheet 1 of 2) - NEMA/UL Type 4

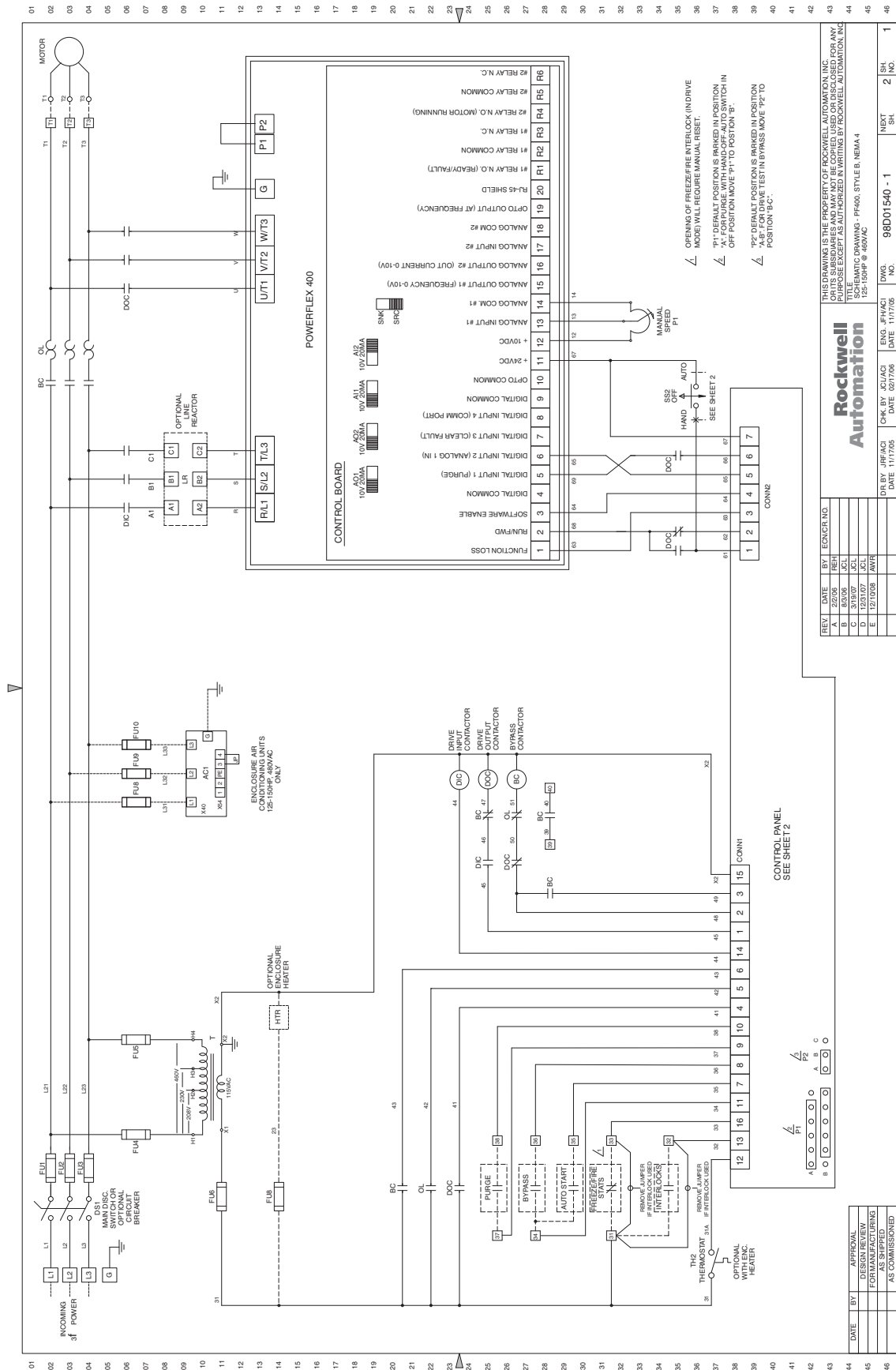

REV	DATE	BY	REASON	NO.
A	2/20/08	BEH		
B	6/30/08	JCL		
C	3/18/07	JCL		
D	12/10/08	JMR		
E	12/10/08	JMR		

DR BY	JRF/ACI	DATE	11/17/05
CHK BY	JCL/ACI	DATE	02/17/08
ENG.	JF/ACI	NO.	98D01540 - 1
DWG.			
1	SH.	2	SH.
1	NO.		

THIS DRAWING IS THE PROPERTY OF ROCKWELL AUTOMATION, INC. UNLESS OTHERWISE SPECIFIED. IT IS TO BE USED FOR THE PURPOSES EXCEPT AS AUTHORIZED IN WRITING BY ROCKWELL AUTOMATION, INC. SCHEMATIC DRAWING - PF400, STYLE B, NEMA 4

DATE: _____ BY: _____ APPROVAL: _____ FOR MANUFACTURING AS SHIPPED AS COMMISSIONED

DATE: _____ BY: _____ APPROVAL: _____ FOR MANUFACTURING AS SHIPPED AS COMMISSIONED

Figure 81 - 125...150 Hp, 460V AC Drives (Sheet 2 of 2) - NEMA/UL Type 4

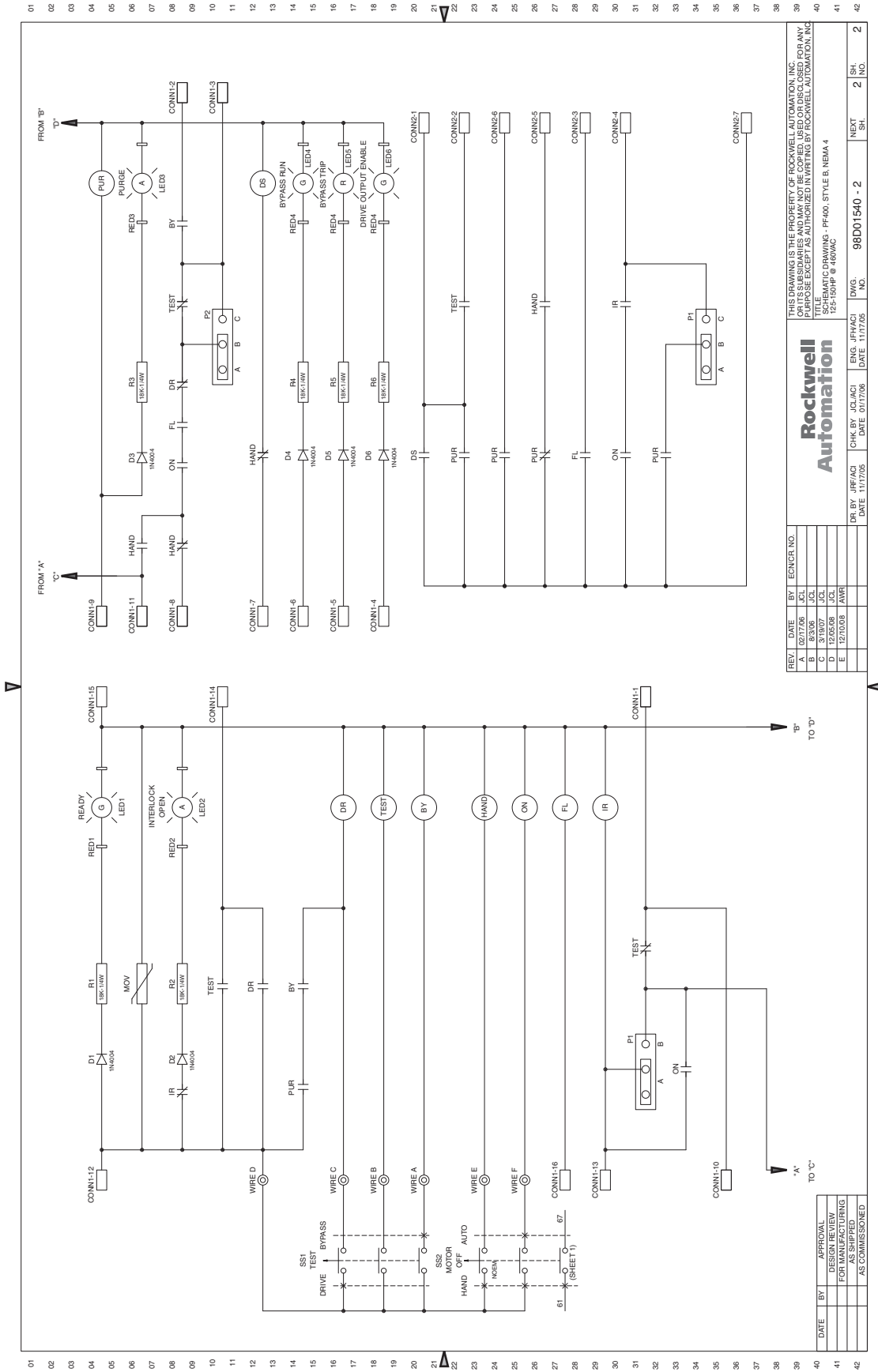

REV.	DATE	BY	ECNCR NO.
A	6/17/06	JCL	
B	8/13/07	JCL	
C	3/19/07	JCL	
D	12/05/08	JCL	
E	12/05/08	AWR	

DATE	BY	APPROVAL
		DESIGN REVIEW
		FOR MANUFACTURING
		AS COMMISSIONED

THIS DRAWING IS THE PROPERTY OF ROCKWELL AUTOMATION, INC. NO PART OF THIS DRAWING IS TO BE REPRODUCED OR TRANSMITTED IN ANY FORM OR BY ANY MEANS, ELECTRONIC OR MECHANICAL, INCLUDING PHOTOCOPYING, RECORDING, OR BY ANY INFORMATION STORAGE AND RETRIEVAL SYSTEM, WITHOUT THE WRITTEN PERMISSION OF ROCKWELL AUTOMATION, INC.

FILE NAME: C:\DRAWING - PF460, STYLE B, NEMA 4
 125-150HP @ 460VAC

Rockwell Automation

DR BY: JWF/ACJ DATE: 01/17/08
 CHK BY: JCL/ACJ DATE: 01/17/08
 ENGR: JPH/ACI
 DWG. NO.: 98D01540 - 2
 NEXT SH. NO.: 2

Figure 82 - 3.0...50 Hp, 208V AC and 3.0...150 Hp, 460V AC Drives (Sheet 1 of 2) - NEMA/UL Type 3R

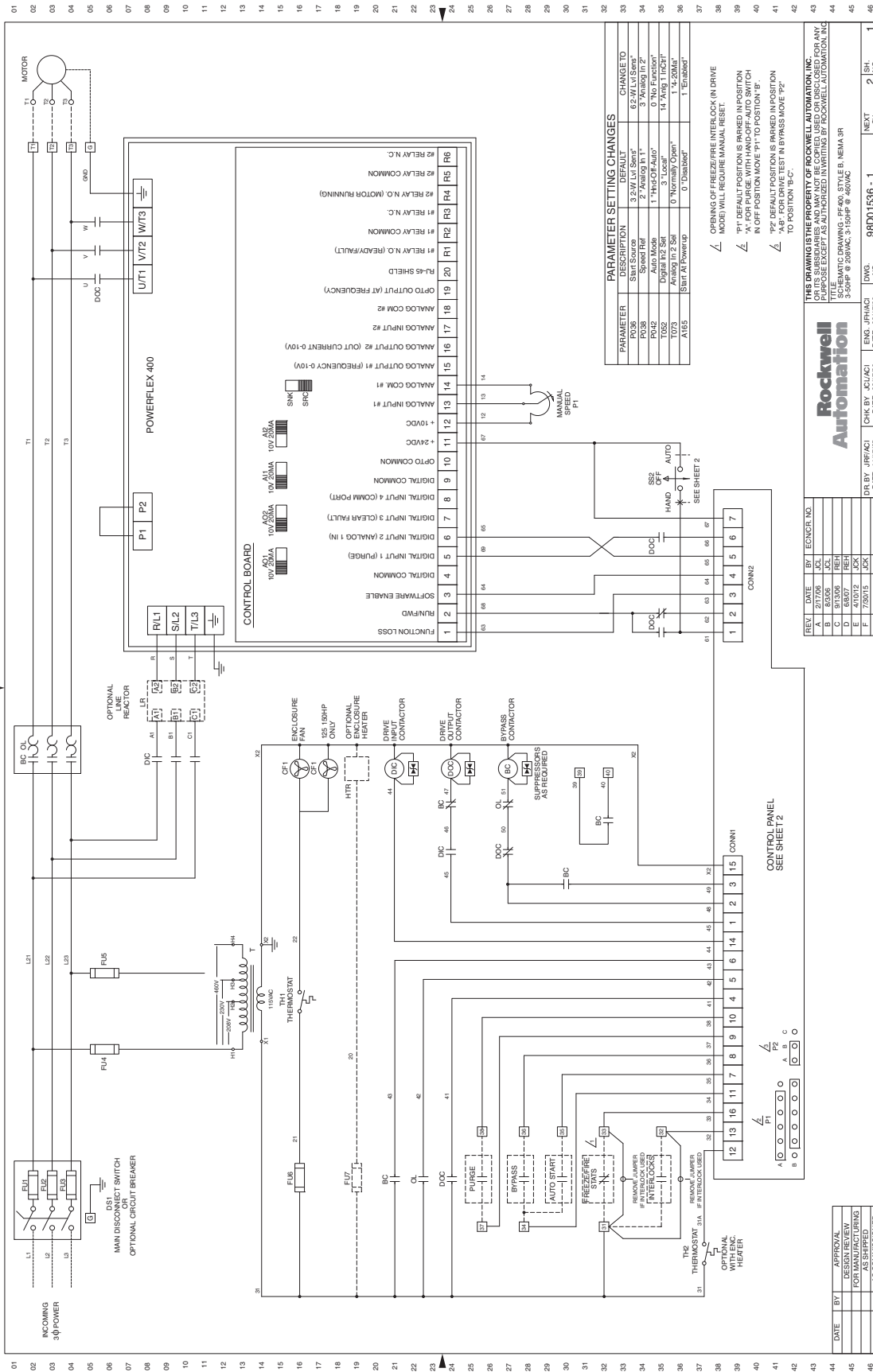
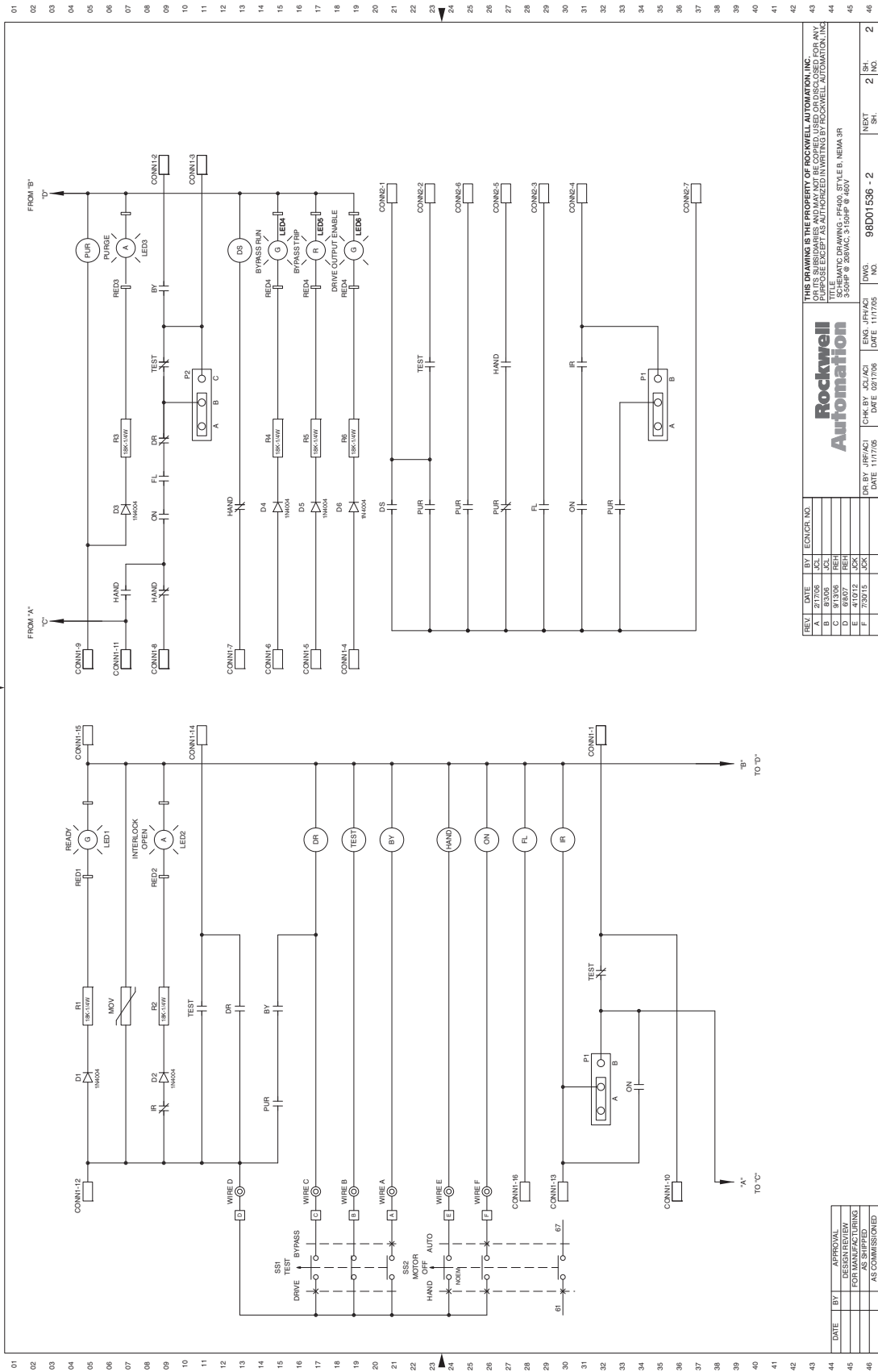

Figure 83 - 3.0...50 Hp, 208V AC and 3.0...150 Hp, 460V AC Drives (Sheet 2 of 2) - NEMA/UL Type 3R



Interconnect Drawings

Figure 84 - 3.0...50 Hp, 208V AC and 3.0...150 Hp, 460V AC Drives - NEMA/UL Type 1

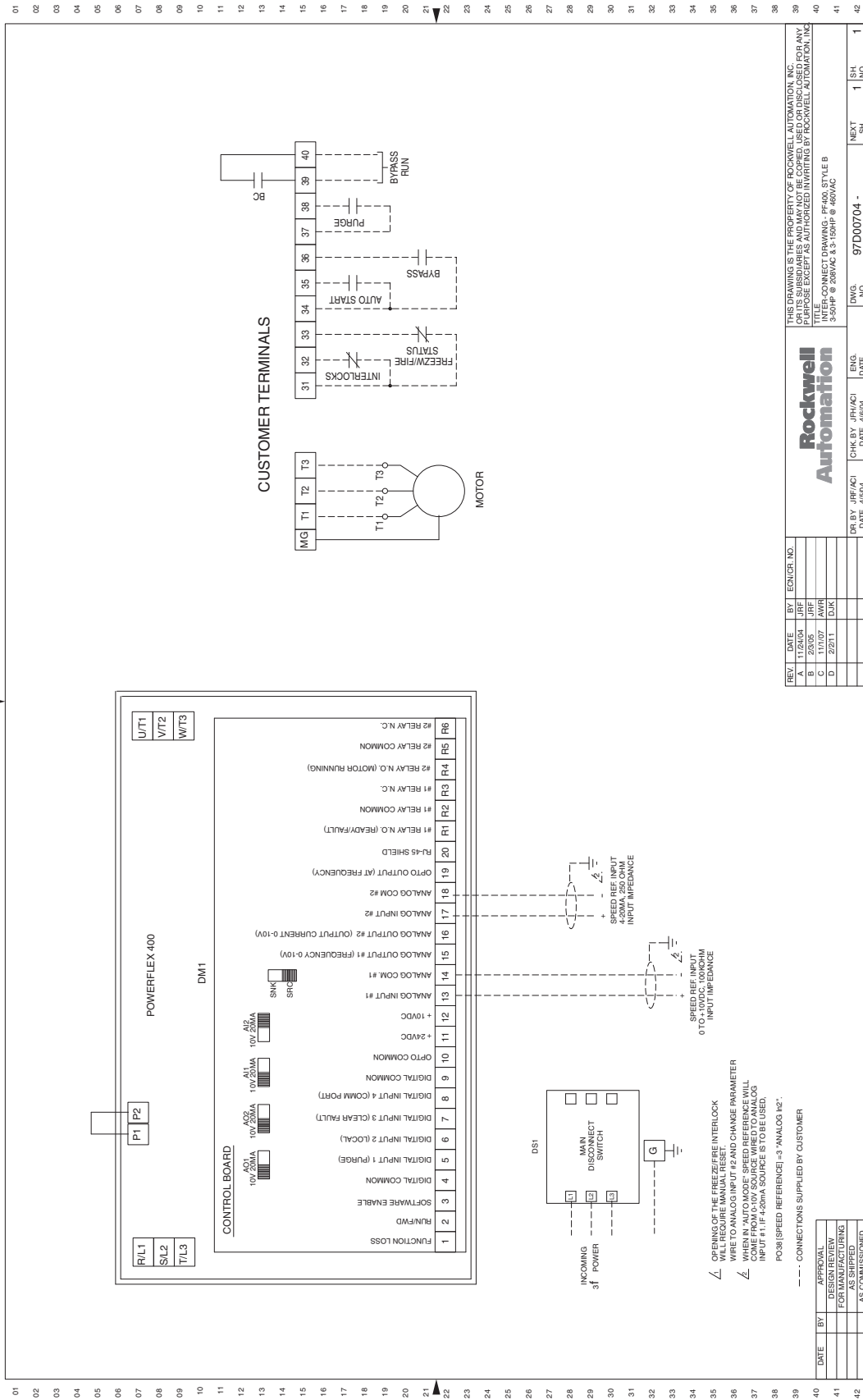
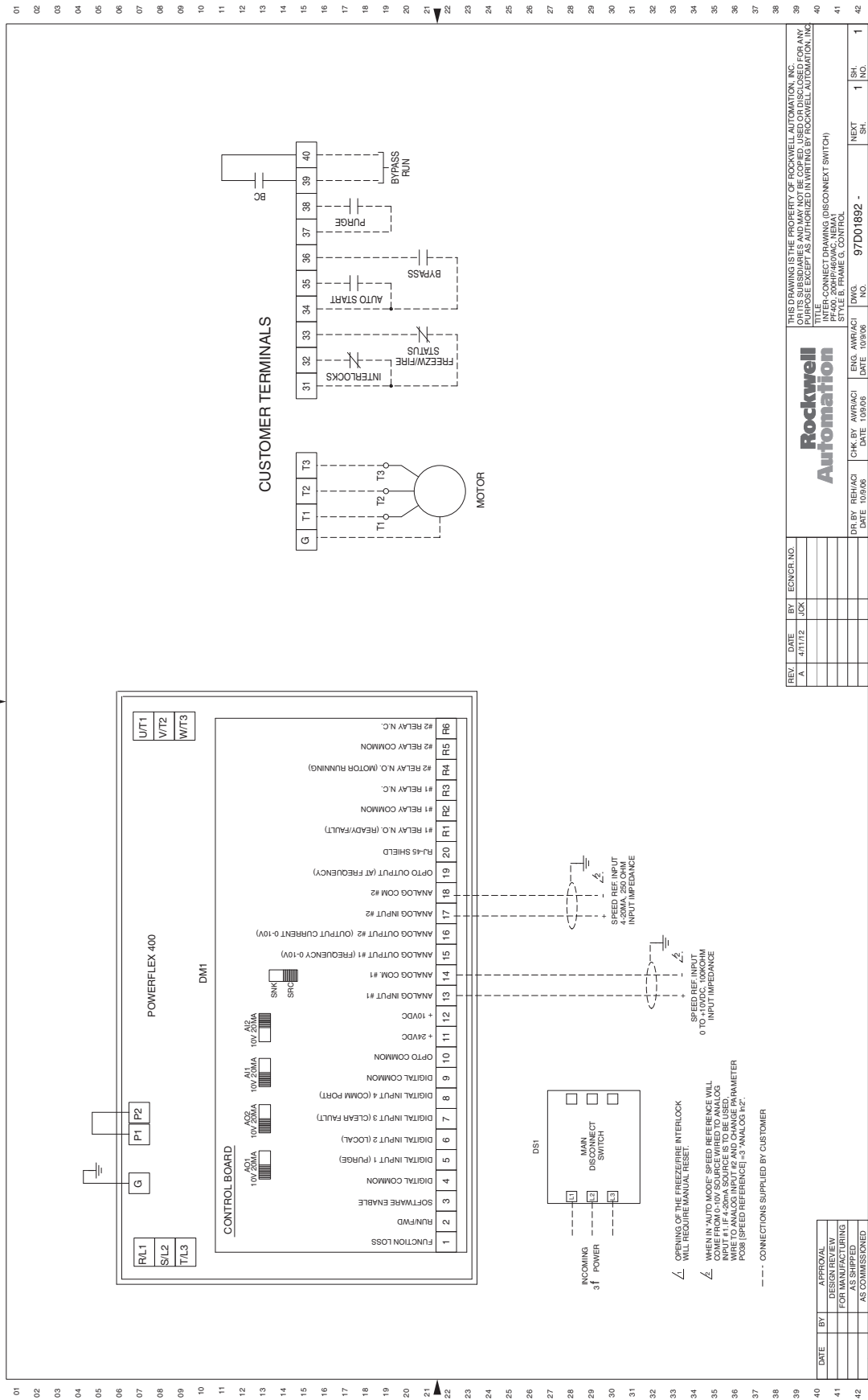

Figure 85 - 200 Hp, 460V AC Drives - NEMA/UL Type 1



DATE	BY	APPROVAL
		DESIGN REVIEW FOR MANUFACTURING
		AS SHIPPED
		AS COMMISSIONED

REV.	DATE	BY	EGNCR. NO.
A	4/11/12	JCK	

DR. BY	REHACI	CHK. BY	AMRACI	ENG. AMRACI	DATE	10/26/08	NO.		

Rockwell Automation	
THIS DRAWING IS THE PROPERTY OF ROCKWELL AUTOMATION, INC. FOR ANY UNAUTHORIZED REPRODUCTION OR TRANSMISSION OF ANY KIND, PURPOSE EXCEPT AS AUTHORIZED IN WRITING BY ROCKWELL AUTOMATION, INC.	
TITLE	CONNECT DRAWING (DISCONNECT SWITCH)
FRAME #	PF400, 200HP/460VAC, NEMA1
REV.	1
DWG. NO.	97D01892 -
REV. NO.	

△ OPENING OF THE FREEZE/FRE INTERLOCK WILL REQUIRE MANUAL RESET.

Δ WHEN IN "AUTO MODE" SPEED REFERENCE WILL COME FROM 0-10V SOURCE WIRED TO ANALOG INPUT #1 IF 4.20MA SOURCE IS TO BE USED. OTHERWISE SPEED REFERENCE WILL COME FROM PC38 (SPEED REFERENCE) 4-3 "ANALOG IN2".

--- CONNECTIONS SUPPLIED BY CUSTOMER

Figure 86 - 250...350 Hp, 460V AC Drives - NEMA/UL Type 1

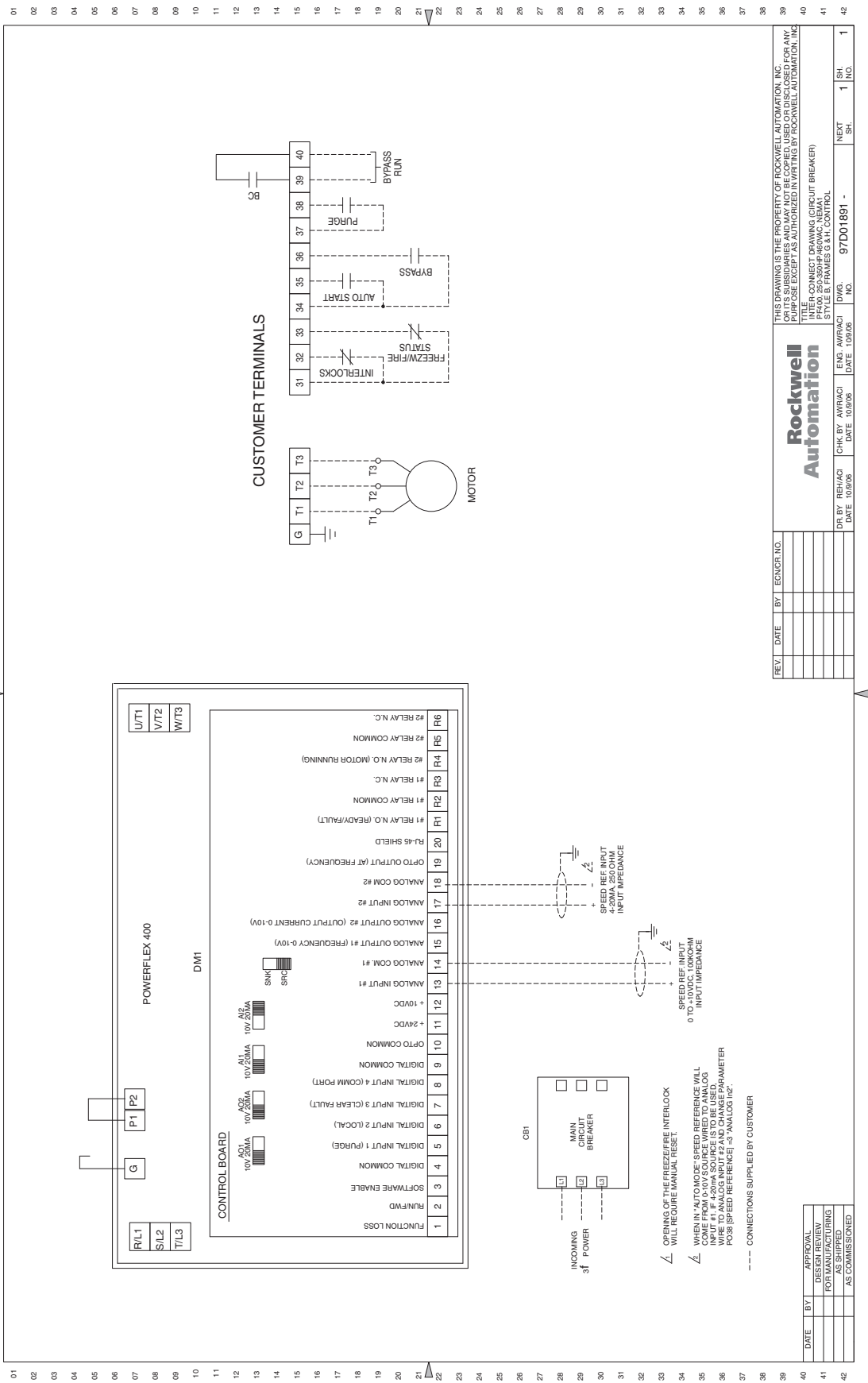

Figure 87 - 3.0...50 Hp, 208V AC and 3.0...100 Hp, 460V AC Drives with Line Reactor - NEMA/UL Type 1

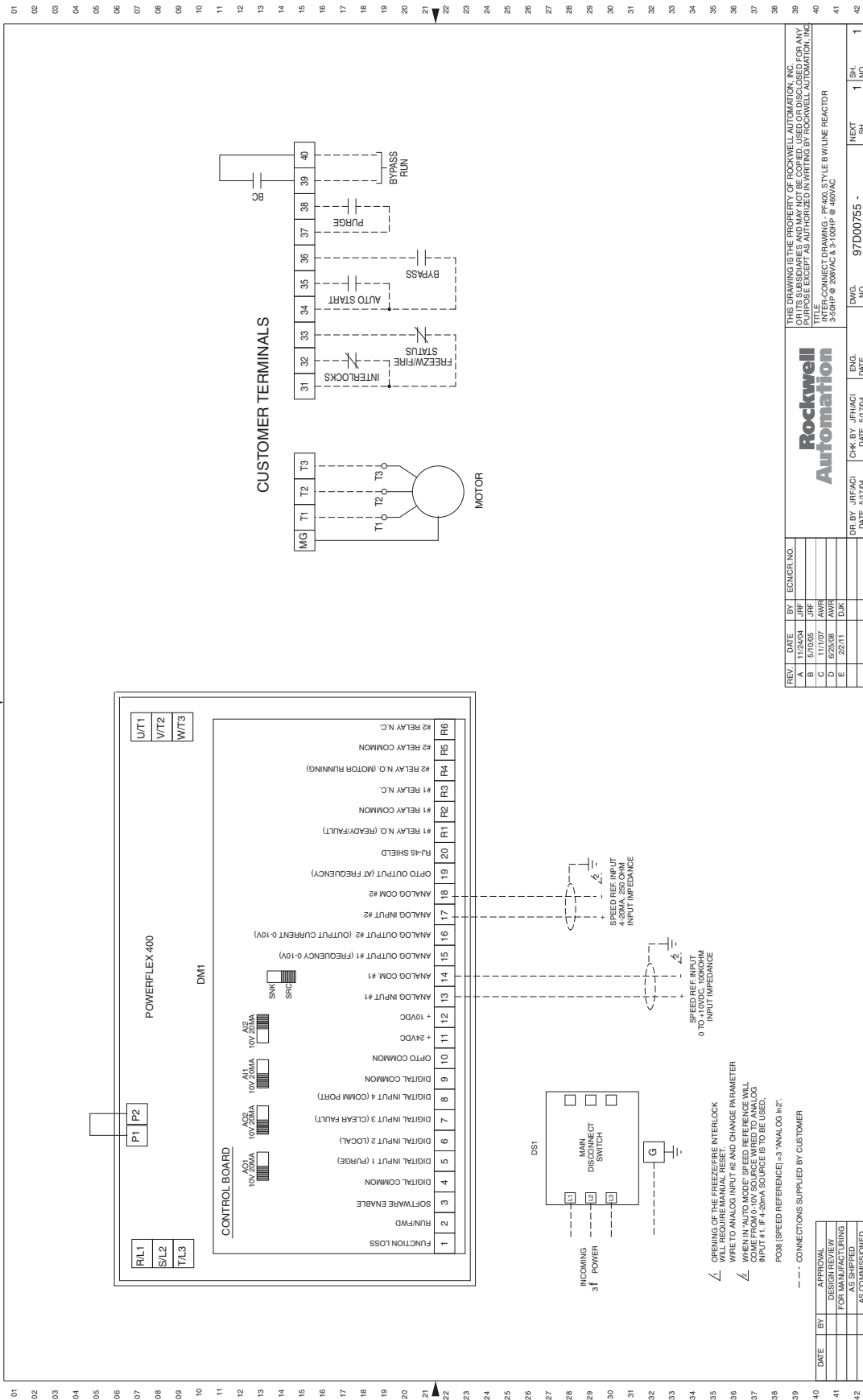
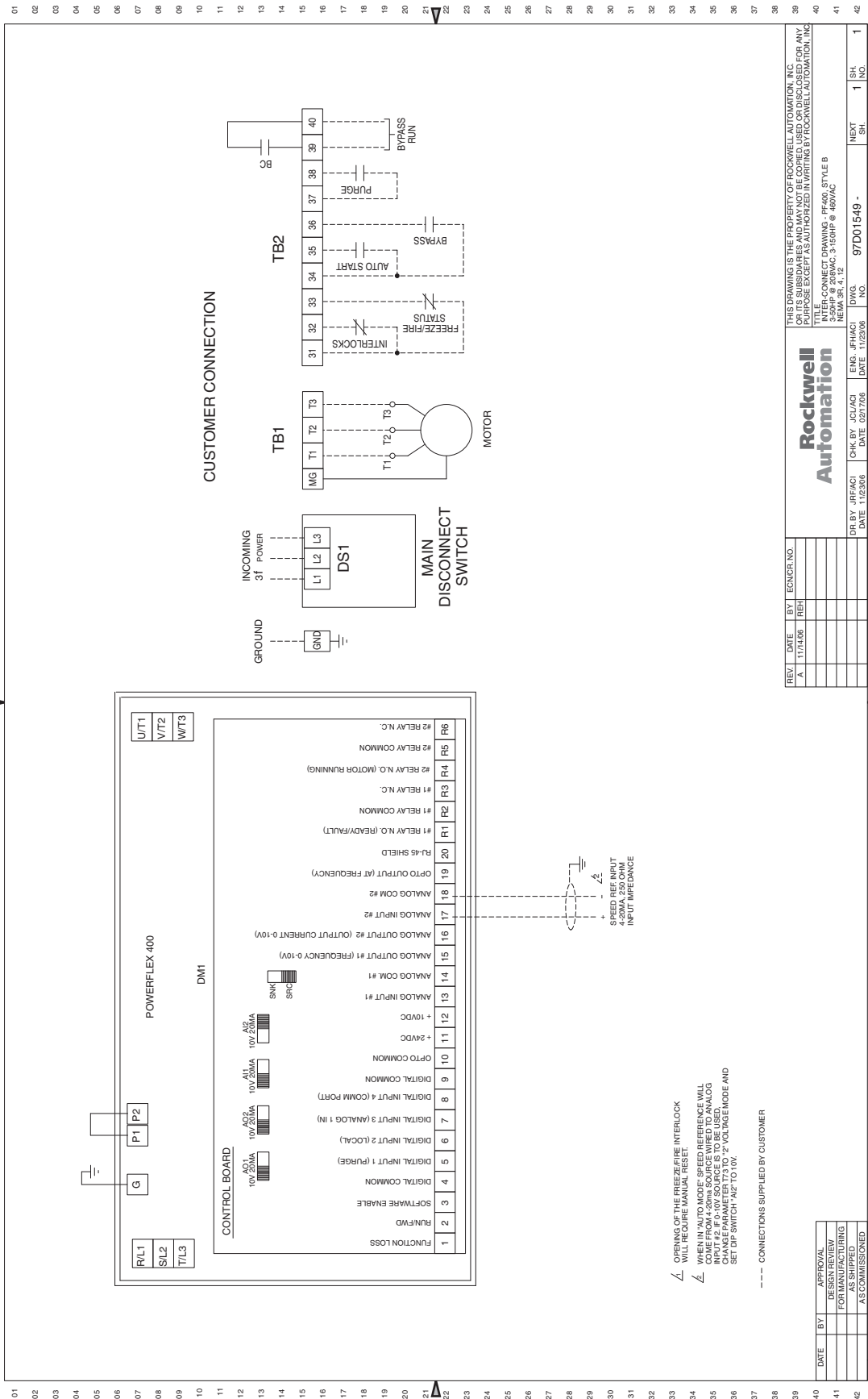
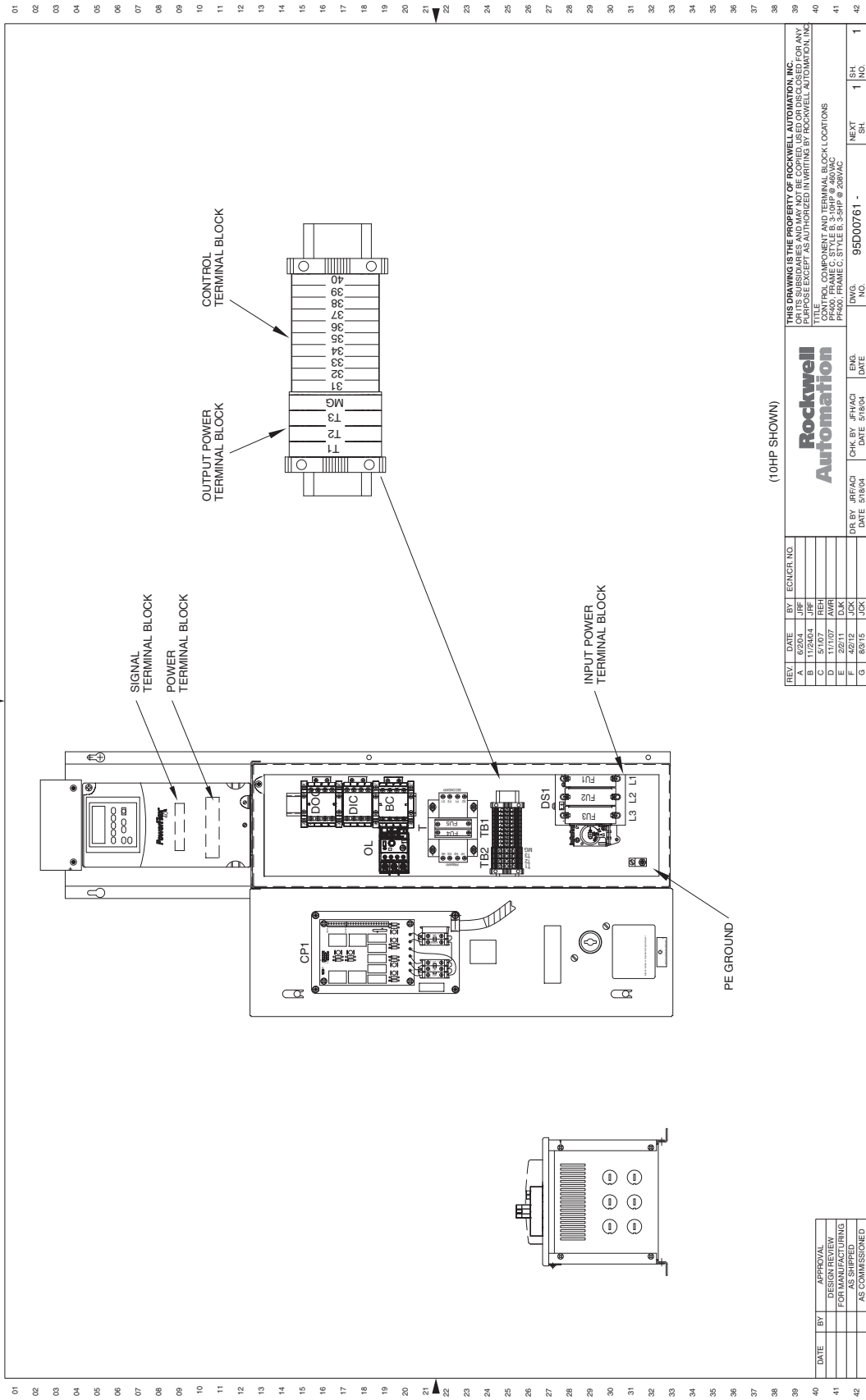

Figure 88 - 3.0...50 Hp, 208V and 3.0...150 Hp, 460V AC Drives - NEMA/UL Type 12, 4, 3R



Layout Drawings

Figure 89 - 3.0...5.0 Hp, 208V AC and 3.0...10 Hp, 460V AC Drives - NEMA/UL Type 1



(10HP SHOWN)

REV.	DATE	BY	ENGR. NO.	CHK. BY	DATE	ENGR.	NO.	SH.	NO.
A	8/28/04	JRF		JRF	5/18/04	JDK			
B	11/24/04	JRF		JRF	5/17/07	JDK			
C	5/17/07	JRF		JRF	2/22/11	JDK			
D	2/22/11	JDK		JDK	4/2/12	JDK			
E	4/2/12	JDK		JDK	8/31/15	JDK			
F	8/31/15	JDK		JDK					
G									

THIS DRAWING IS THE PROPERTY OF ROCKWELL AUTOMATION, INC. OR ITS SUBSIDIARIES AND MAY NOT BE COPIED, USED OR DISCLOSED FOR ANY PURPOSES EXCEPT AS AUTHORIZED IN WRITING BY ROCKWELL AUTOMATION, INC.									
TITLE: 3.0...5.0 Hp, 208V AC and 3.0...10 Hp, 460V AC Drives - NEMA/UL Type 1									
CONTROL COMPONENT AND TERMINAL BLOCK LOCATIONS: PH400, FRAME C, STYLE B, 3-SHP @ 208VAC									
DATE	BY	APPROVAL							
		DESIGN REVIEW							
		FOR MANUFACTURING							
		AS SHIPPED							
		AS COMMISSIONED							
								DWG. NO.	95D007/61 -
								REV.	1
								SH.	1
								NO.	

Figure 90 - 7.5...10 Hp, 208V AC and 15...20 Hp, 460V AC Drives - NEMA/UL Type 1

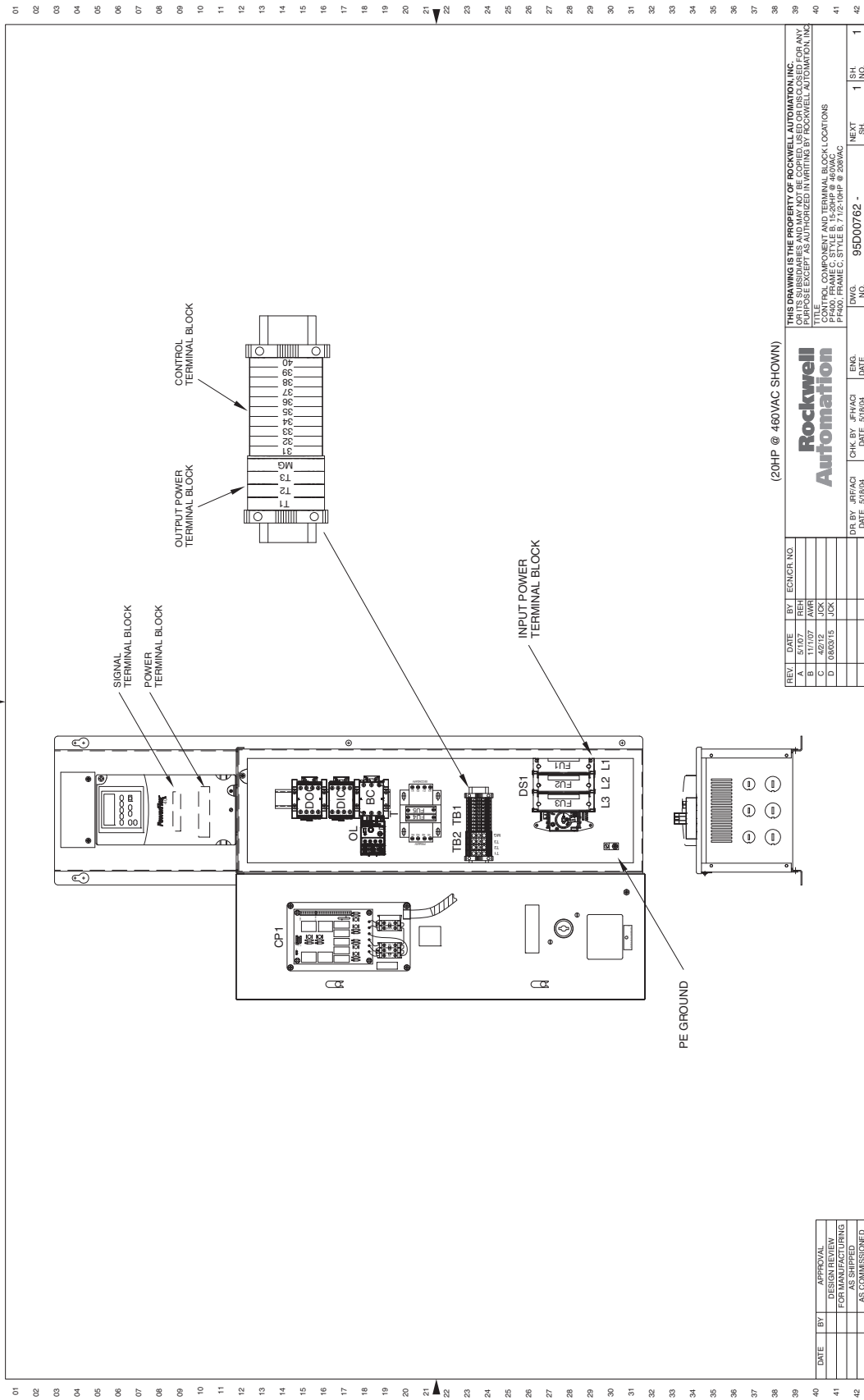

Figure 91 - 15...20 Hp, 208V AC and 25...40 Hp, 460V AC Drives - NEMA/UL Type 1

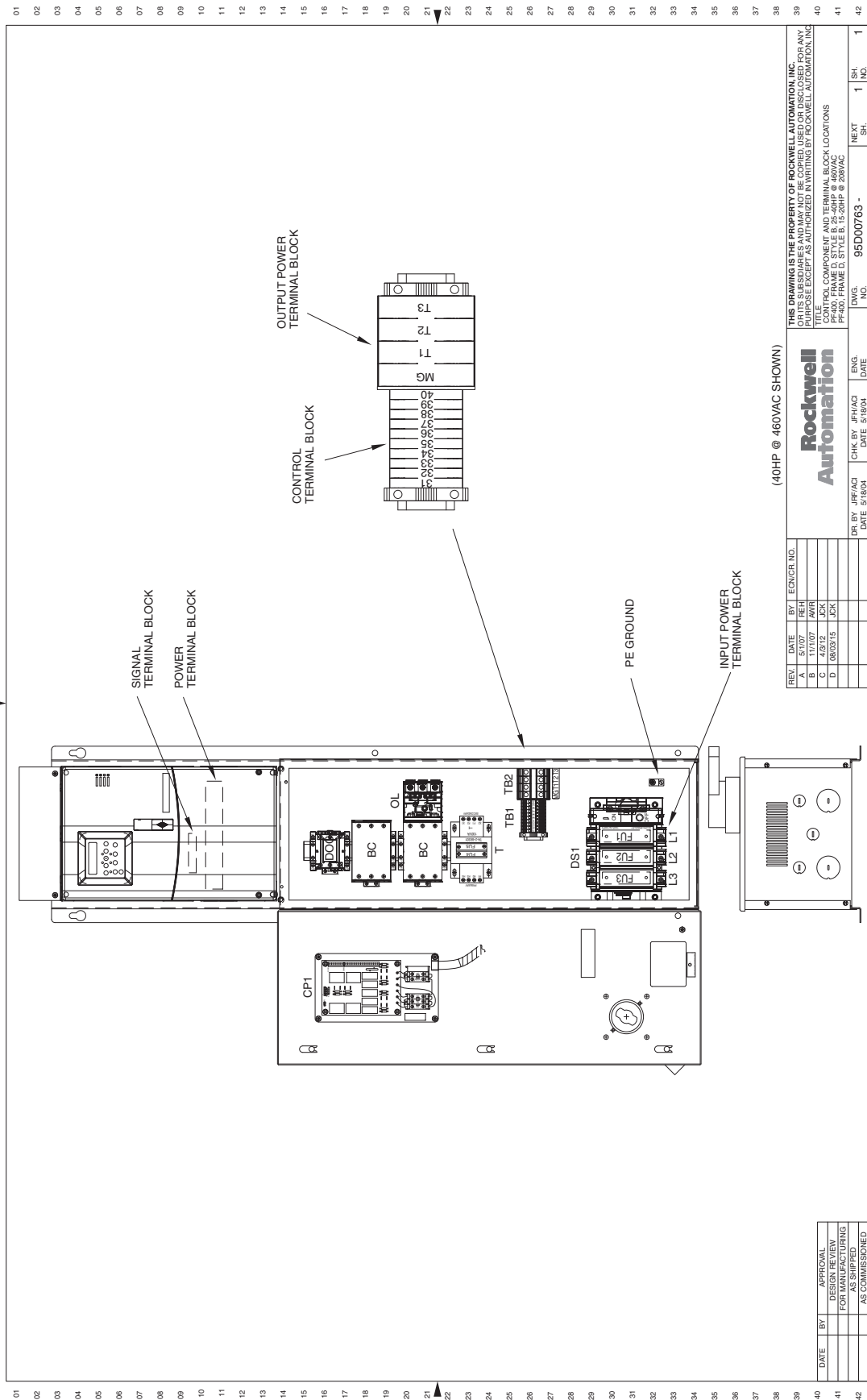

Figure 92 - 25...30 Hp, 208V AC Drives - NEMA/UL Type 1

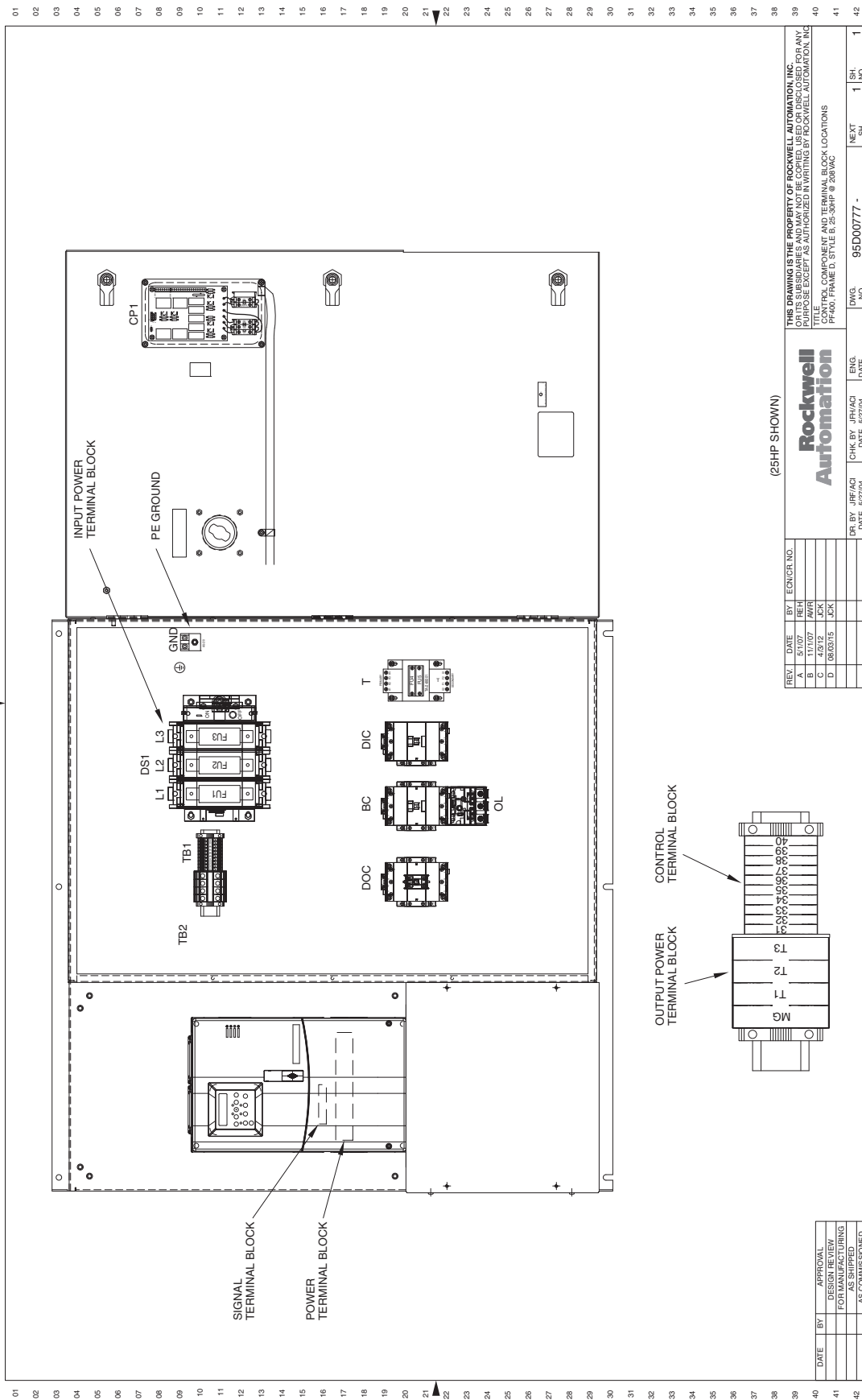

Figure 93 - 50...75 Hp, 460V AC Drives - NEMA/UL Type 1

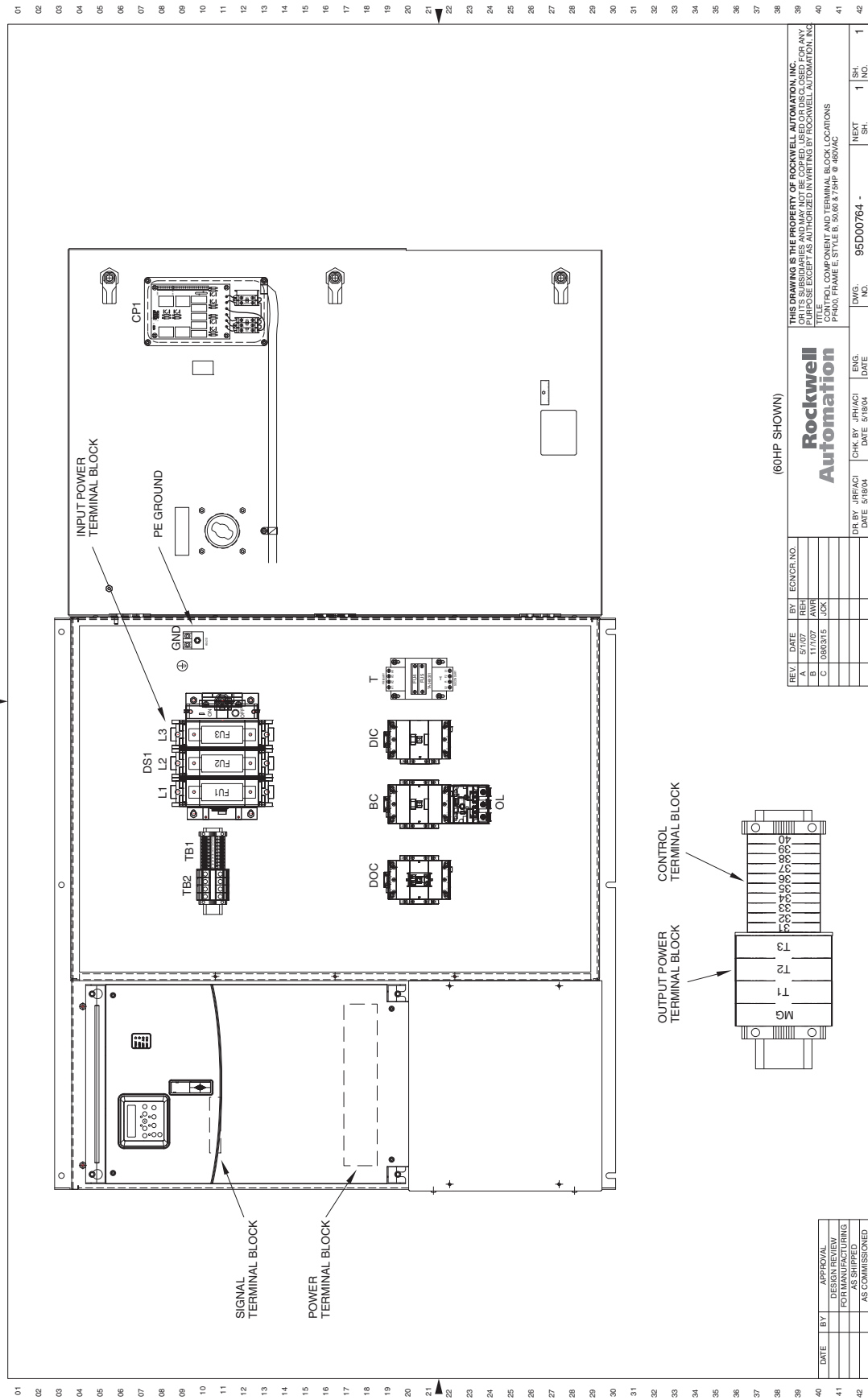
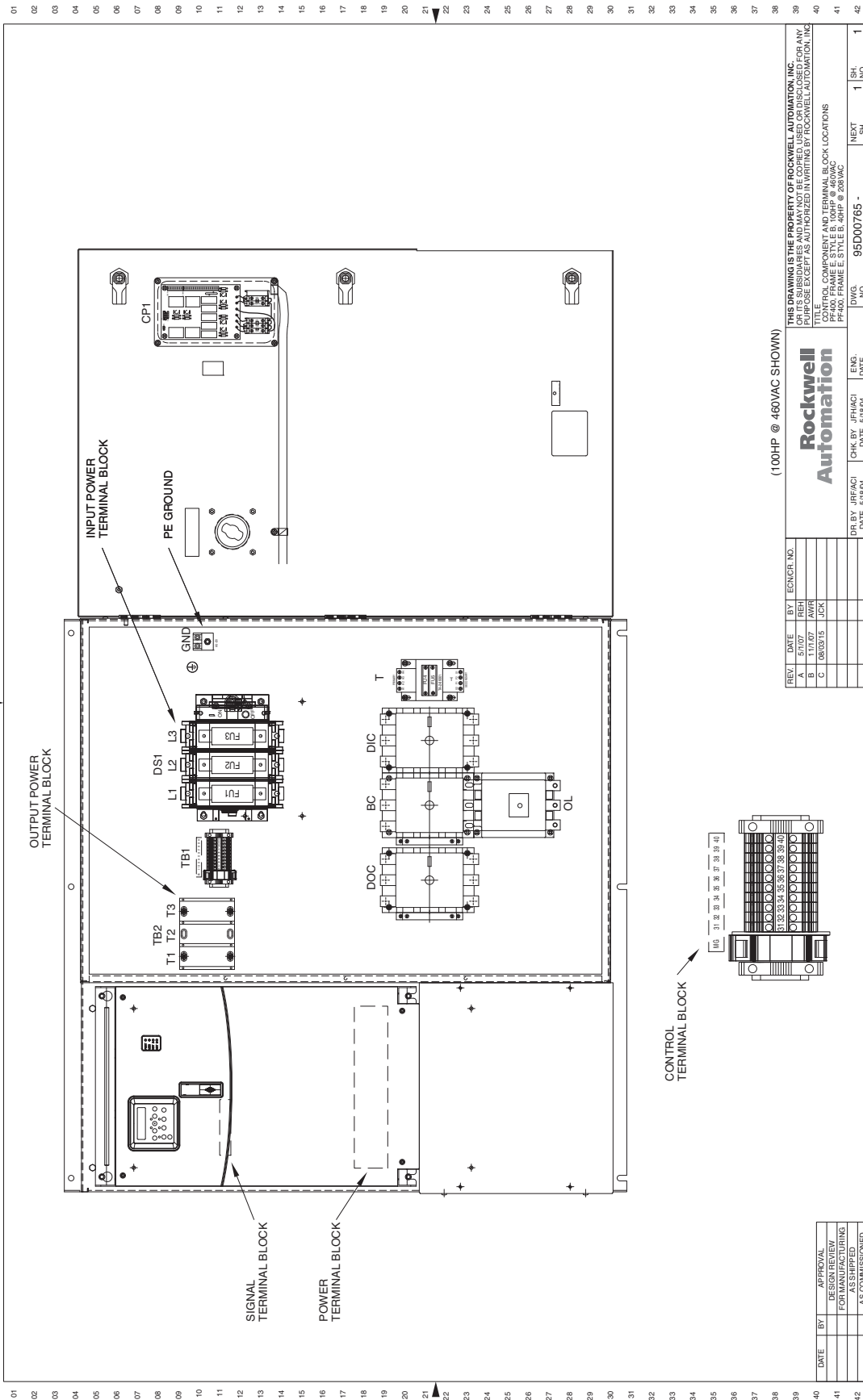

Figure 94 - 40 Hp, 208V AC and 100 Hp, 460V AC Drives - NEMA/UL Type 1



(100HP @ 460VAC SHOWN)

REV.	DATE	BY	ECNOR. NO.
A	5/7/07	JRH	
B	1/2/08	JSA	
C	1/28/2015	JSA	

THIS DRAWING IS THE PROPERTY OF ROCKWELL AUTOMATION, INC. IT IS TO BE USED FOR THE SPECIFIC PROJECT AND NOT BE REPRODUCED OR COPIED FOR ANY OTHER PURPOSE EXCEPT AS AUTHORIZED IN WRITING BY ROCKWELL AUTOMATION, INC.

TITLE: 3 CONTACTOR FULL FEATURE BYPASS WITH DISCONNECT PACKAGE LOCATIONS
 PART NO.: 95D00765 - 100HP @ 460VAC
 FRAME STYLE: B/N
 FRAME SIZE: 40HP @ 208VAC
 FRAME STYLE: B/N
 FRAME SIZE: 40HP @ 208VAC

DR. BY: JRF/ACI	DATE: 5/16/04	ENG. DATE: 5/16/04	NO.	DWG. NO.	1	SH. NO.	1
-----------------	---------------	--------------------	-----	----------	---	---------	---

DATE	BY	APPROVAL
		DESIGN REVIEW
		FOR MANUFACTURING
		AS SHIPPED
		AS COMMISSIONED

01
02
03
04
05
06
07
08
09
10
11
12
13
14
15
16
17
18
19
20
21
22
23
24
25
26
27
28
29
30
31
32
33
34
35
36
37
38
39
40
41
42

Figure 95 - 50 Hp, 208V AC Drives - NEMA/UL Type 1

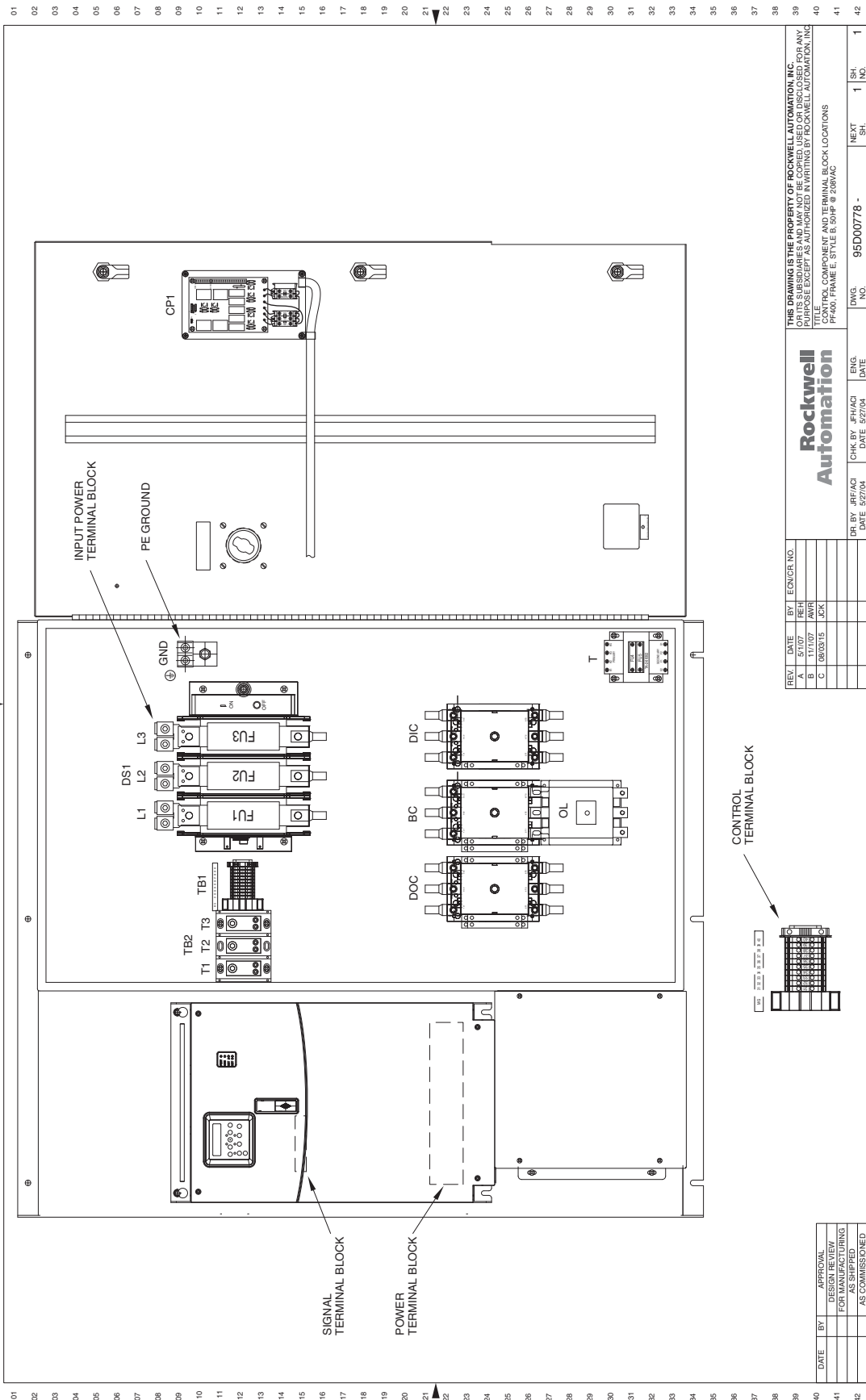

Figure 96 - 125...150 Hp, 460V AC Drives - NEMA/UL Type 1

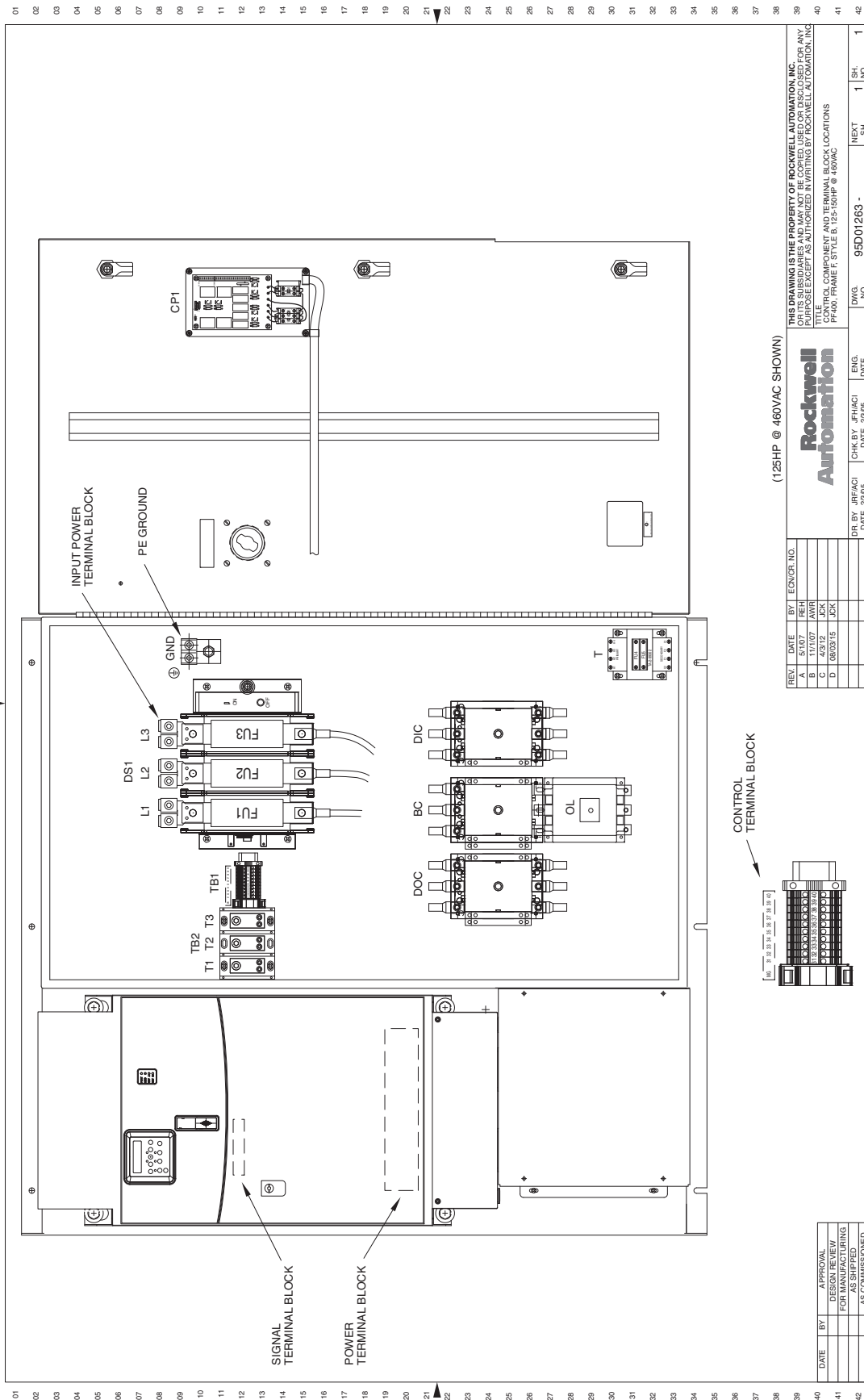
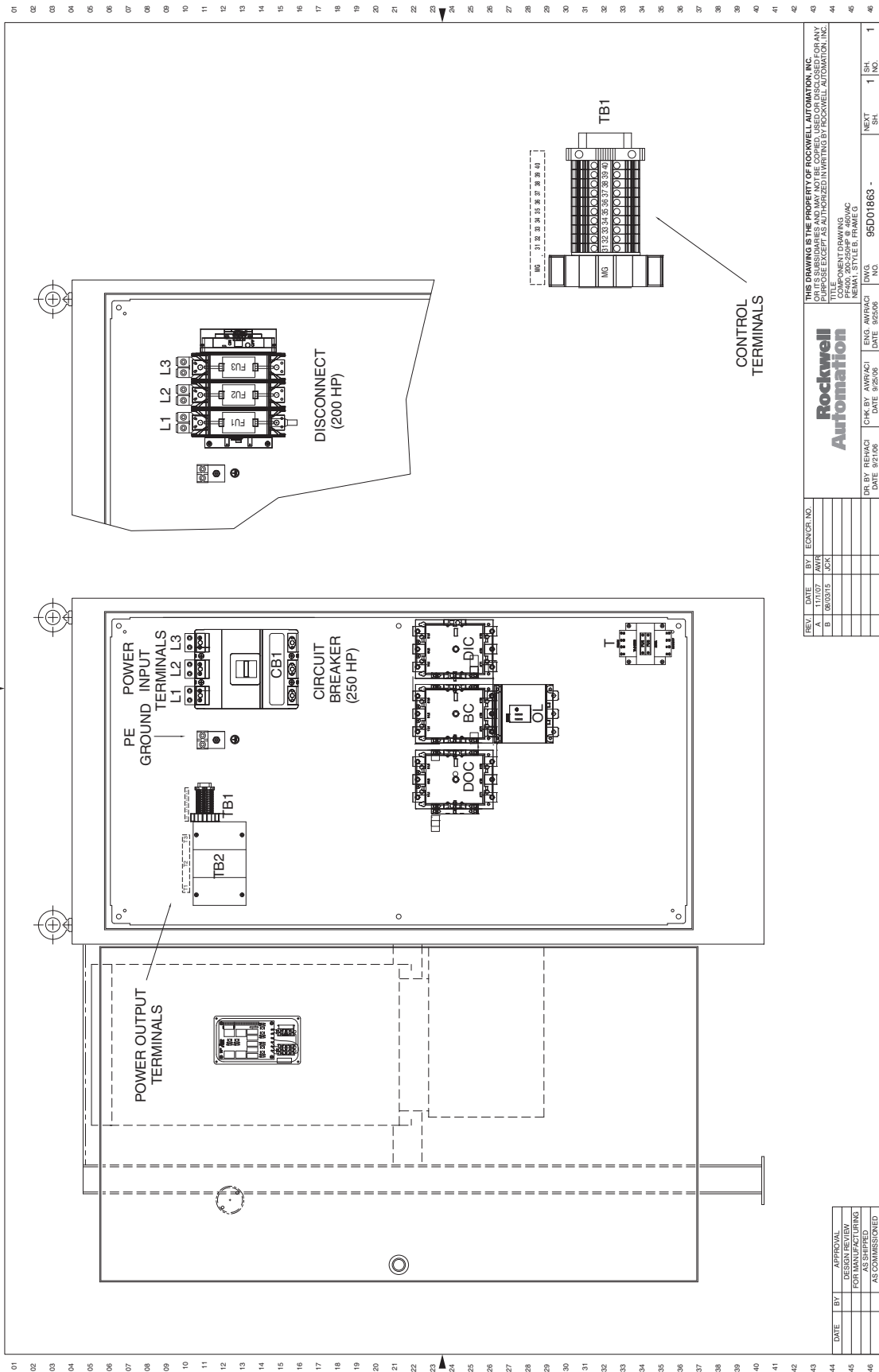

Figure 97 - 200...250 Hp, 460V AC Drives - NEMA/UL Type 1



REV	DATE	BY	ENGR	NO.
B	08/03/15	AWR	JCK	

THIS DRAWING IS THE PROPERTY OF ROCKWELL AUTOMATION, INC. DRIVERS, SCHEMATIC AND MAY NOT BE COPIED, REPRODUCED OR ANY PURPOSE EXCEPT AS AUTHORIZED IN WRITING BY ROCKWELL AUTOMATION, INC.

COMPONENT DRAWING
NEMA STYLE B, FRAM 1/G

DR BY: REMACI | DATE: 8/21/05
CHK BY: AWRACI | DATE: 8/25/05
ENG: AWRACI | DATE: 8/25/05

DWG. NO. 95D01863 -
NEXT SH. 1
SH. NO. 1

DATE	BY	APPROVAL
		FOR MANUFACTURING
		AS SHIPPED
		AS COMMISSIONED

Figure 98 - 300...350 Hp, 460V AC Drives - NEMA/UL Type 1

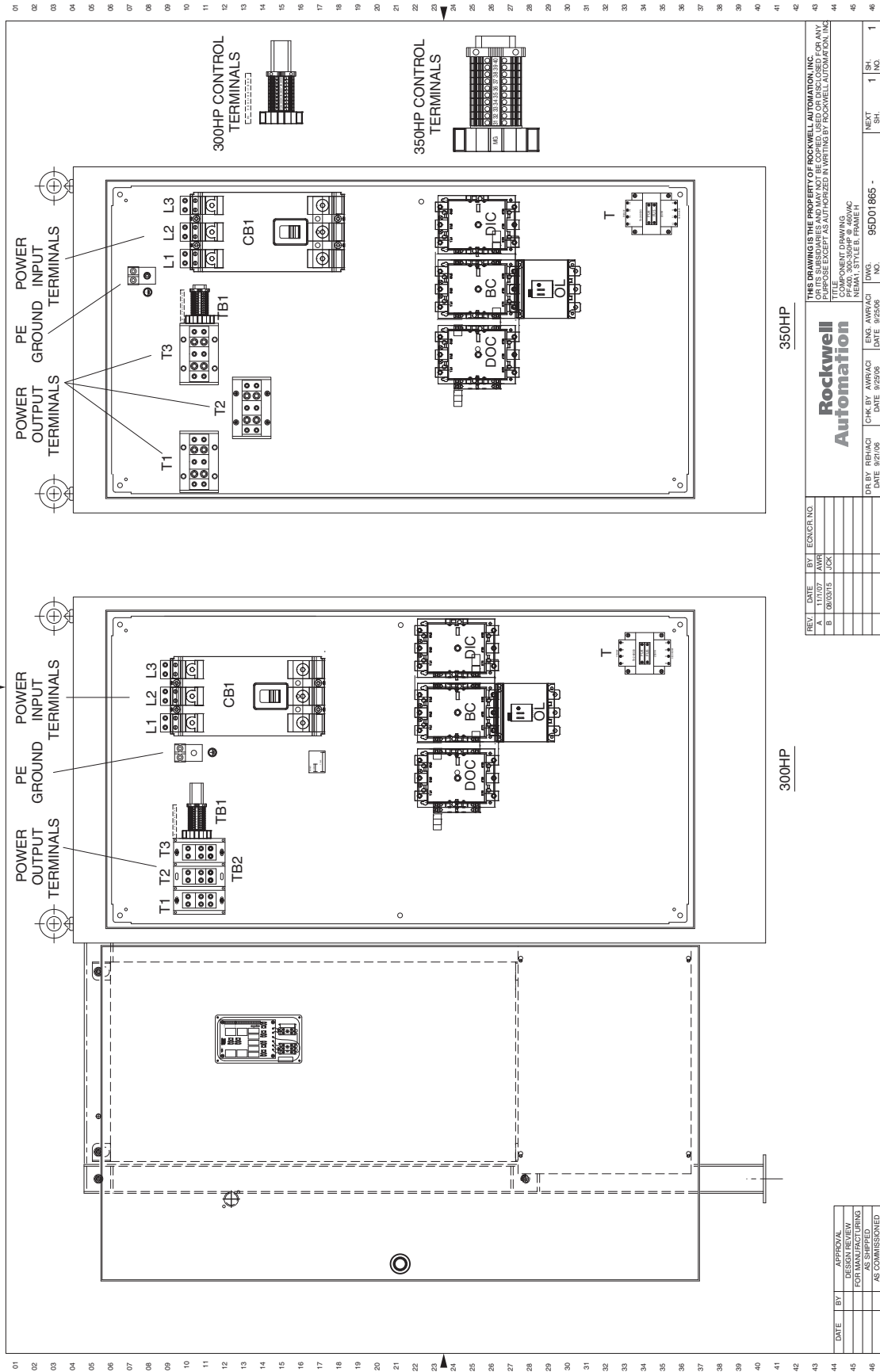

Figure 99 - 3.0...5.0 Hp, 208V AC and 3.0...10 Hp, 460V AC Drives with Line Reactor - NEMA/UL Type 1

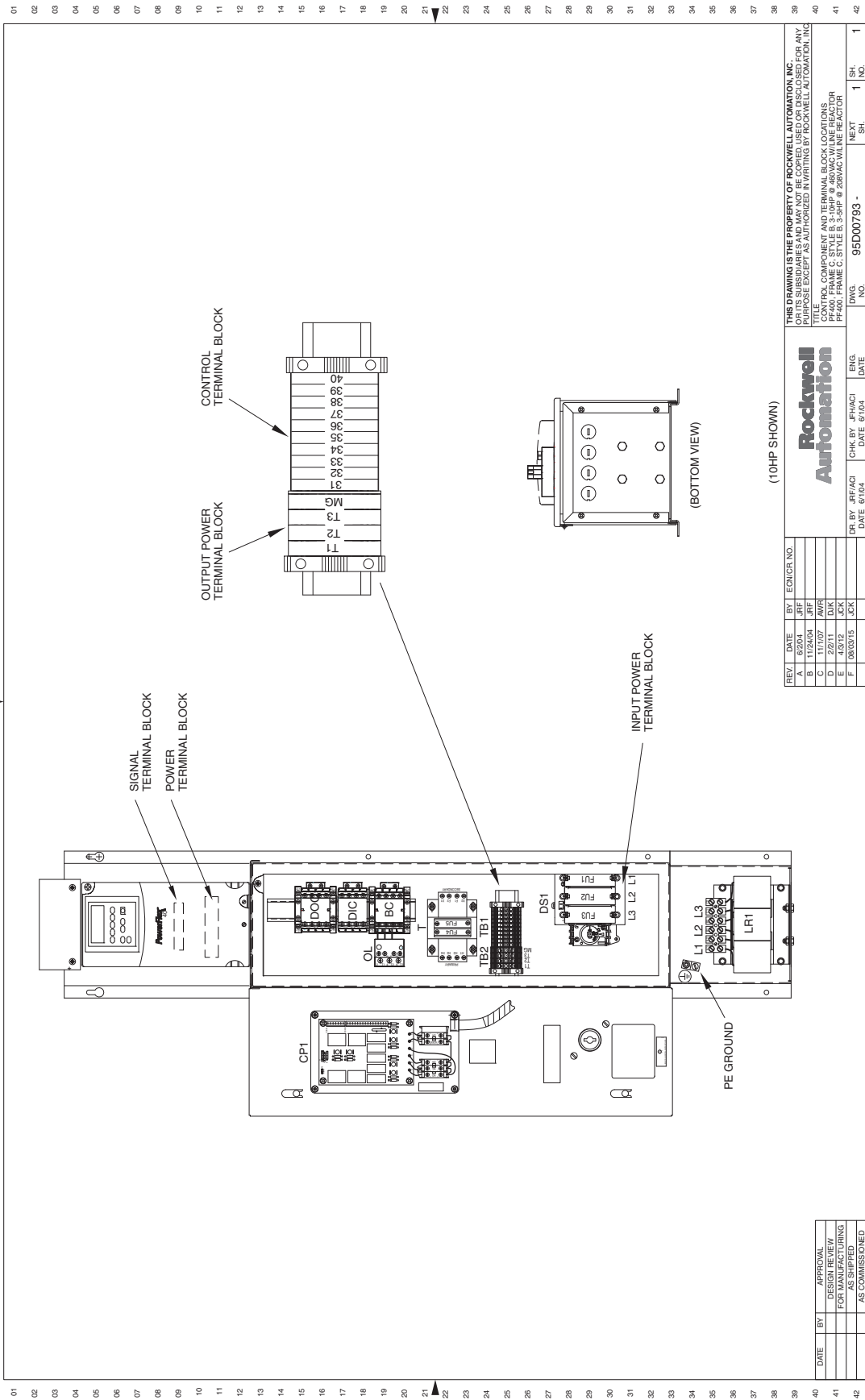
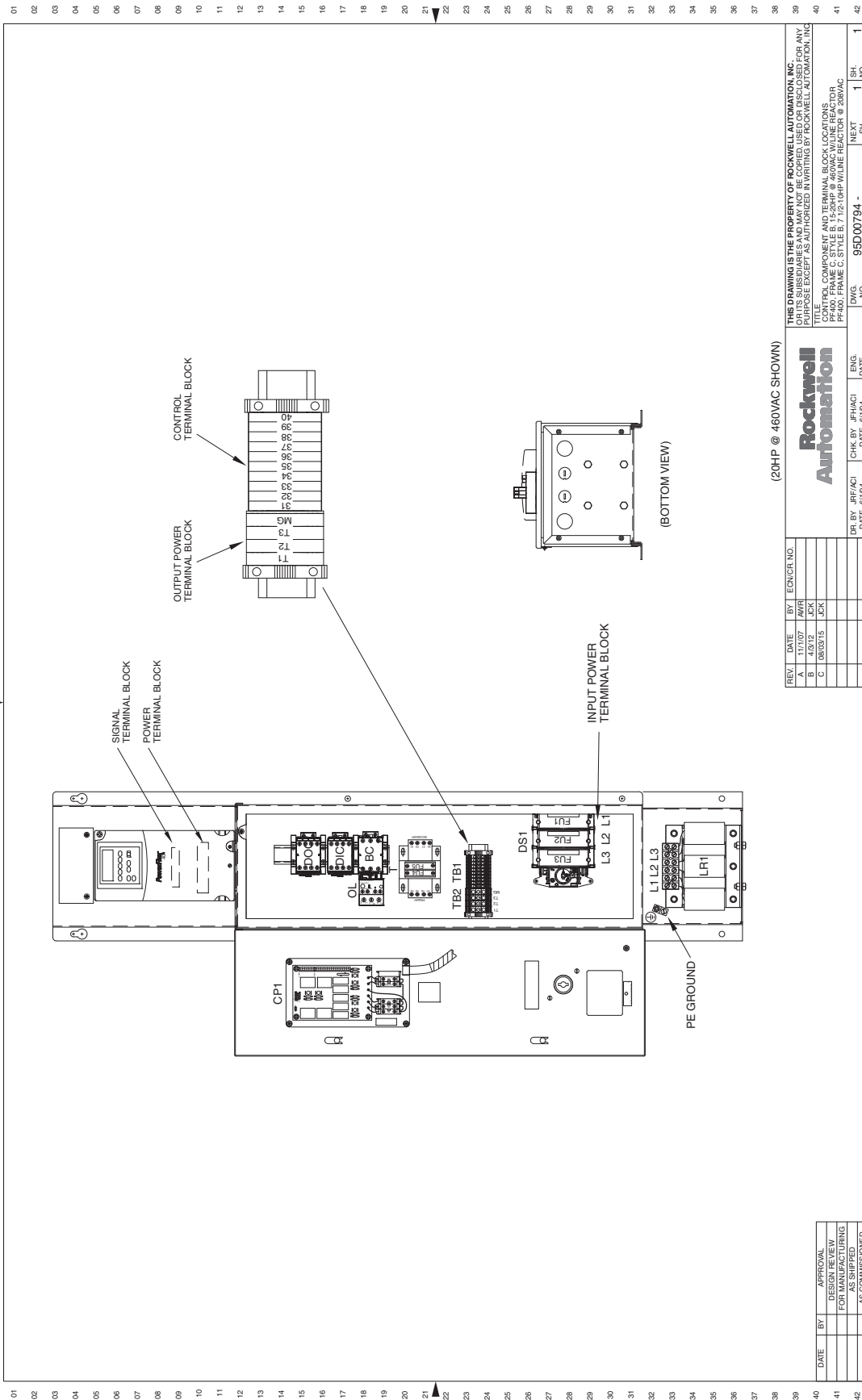

Figure 100 - 7.5...10 Hp, 208V AC and 15...20 Hp, 460V AC Drives with Line Reactor - NEMA/UL Type 1



(20HP @ 460VAC SHOWN)

REV.	DATE	BY	ENGR. NO.	DR. BY	CHK. BY	ENG. DATE	DATE	NO.	SH.	NO.
A	11/17/07	JWR								
B	08/03/15	SK								
C	08/03/15	LEA								

DATE	BY	APPROVAL
		DESIGN REVIEW
		FOR MANUFACTURING
		AS SHIPPED
		AS COMMISSIONED

THIS DRAWING IS THE PROPERTY OF ROCKWELL AUTOMATION, INC. IT IS NOT TO BE REPRODUCED OR TRANSMITTED IN ANY FORM OR BY ANY MEANS, ELECTRONIC OR MECHANICAL, INCLUDING PHOTOCOPYING, RECORDING, OR BY ANY INFORMATION STORAGE AND RETRIEVAL SYSTEM.	
TITLE	3-POLE CONTACTOR WITH TERMINAL BLOCKS WITH LINE REACTOR
PROPERTY	ROCKWELL AUTOMATION
PROJECT	PF400 - FRAME C - STYLE A, 7.5-20HP @ 460VAC, W/LINE REACTOR
DWG. NO.	95D00794 -
ENG. DATE	
DR. BY	JWR/AZI
CHK. BY	JFH/AZI
DATE	8/10/4
NO.	1
SH.	1
NO.	1

Figure 101 - 15...20 Hp, 208V AC and 25...40 Hp, 460V AC Drives with Line Reactor - NEMA/UL Type 1

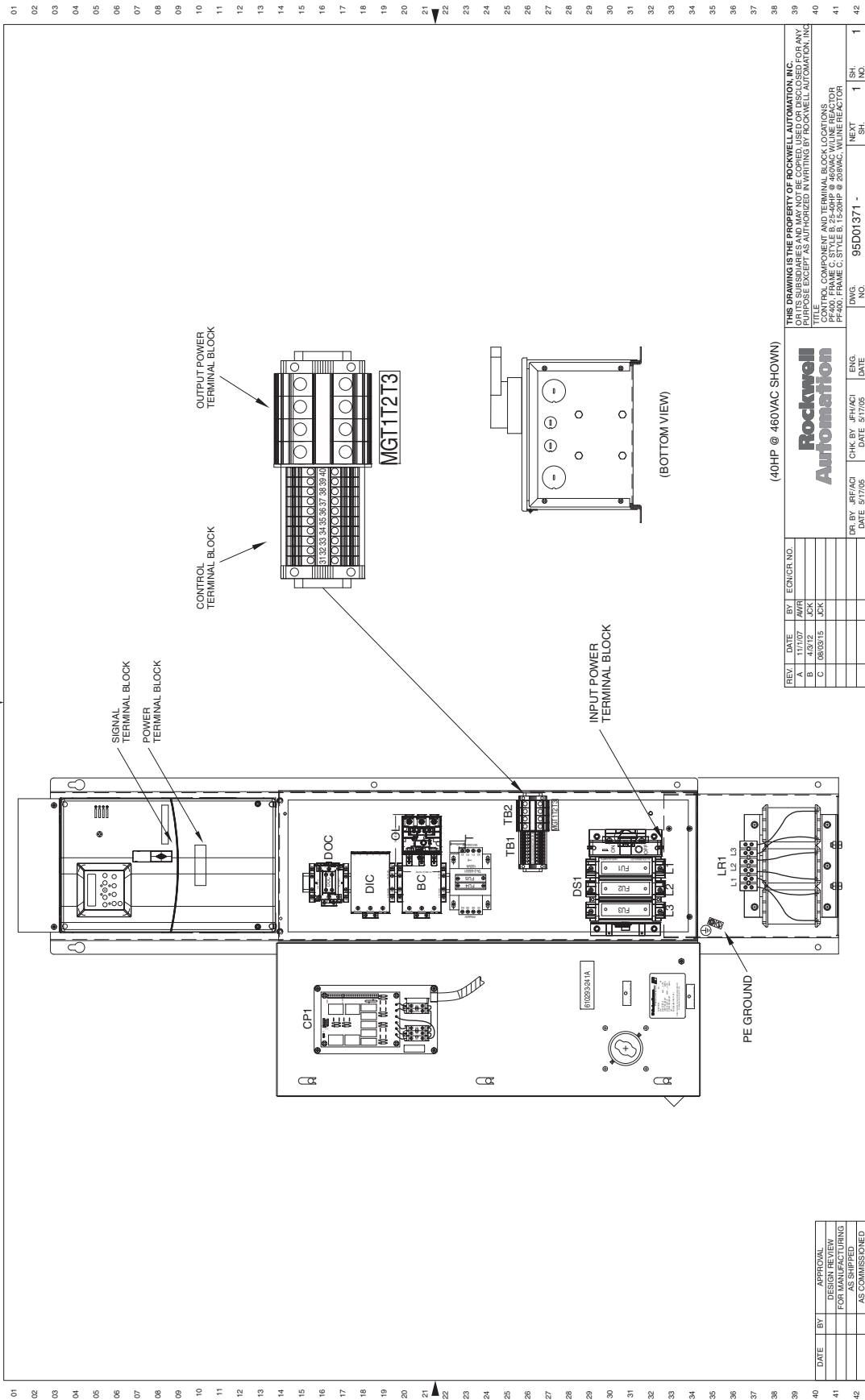

Figure 102 - 25 Hp, 208V AC Drives with Line Reactor - NEMA/UL Type 1

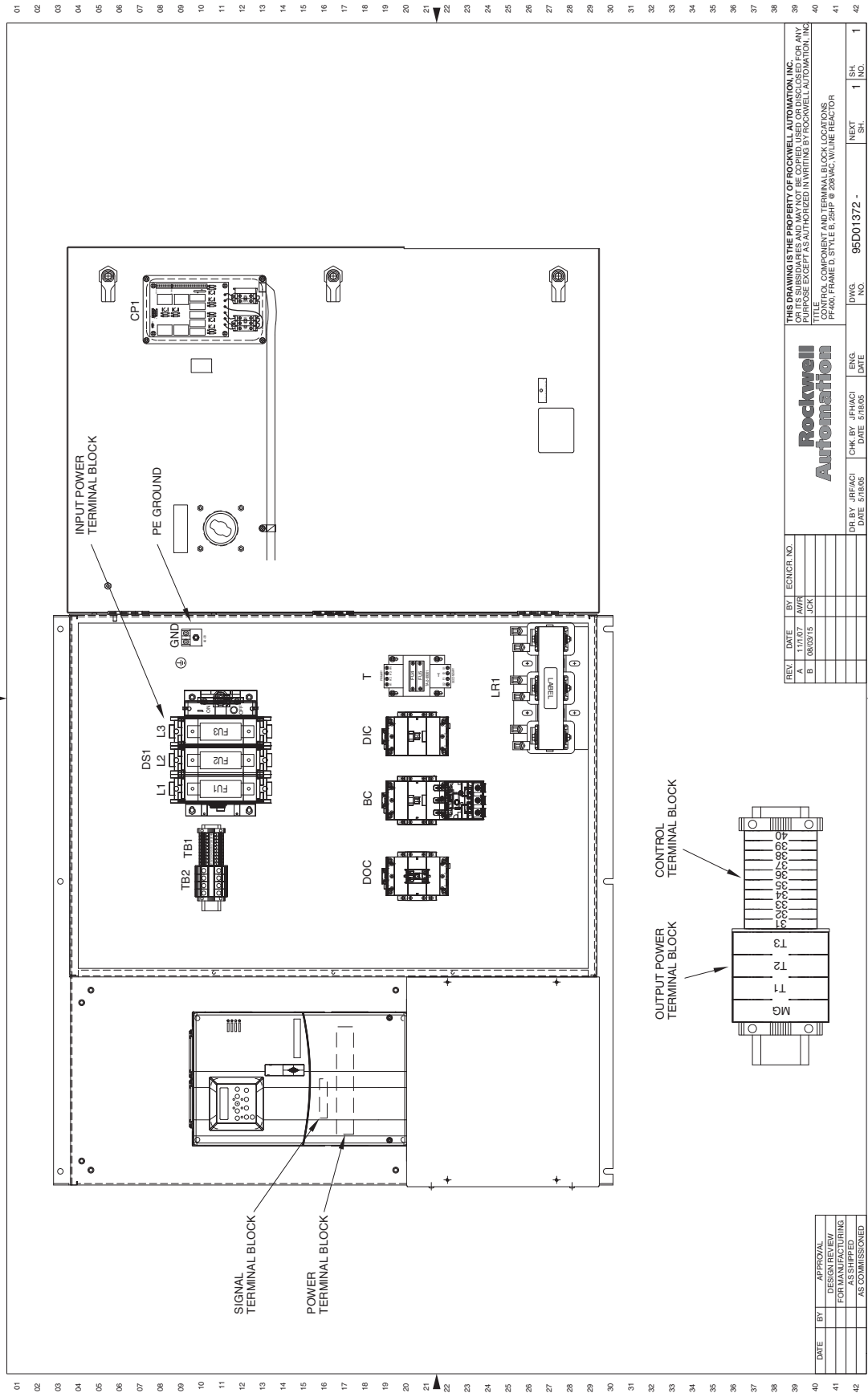

Figure 103 - 30 Hp, 208V AC Drives with Line Reactor - NEMA/UL Type 1

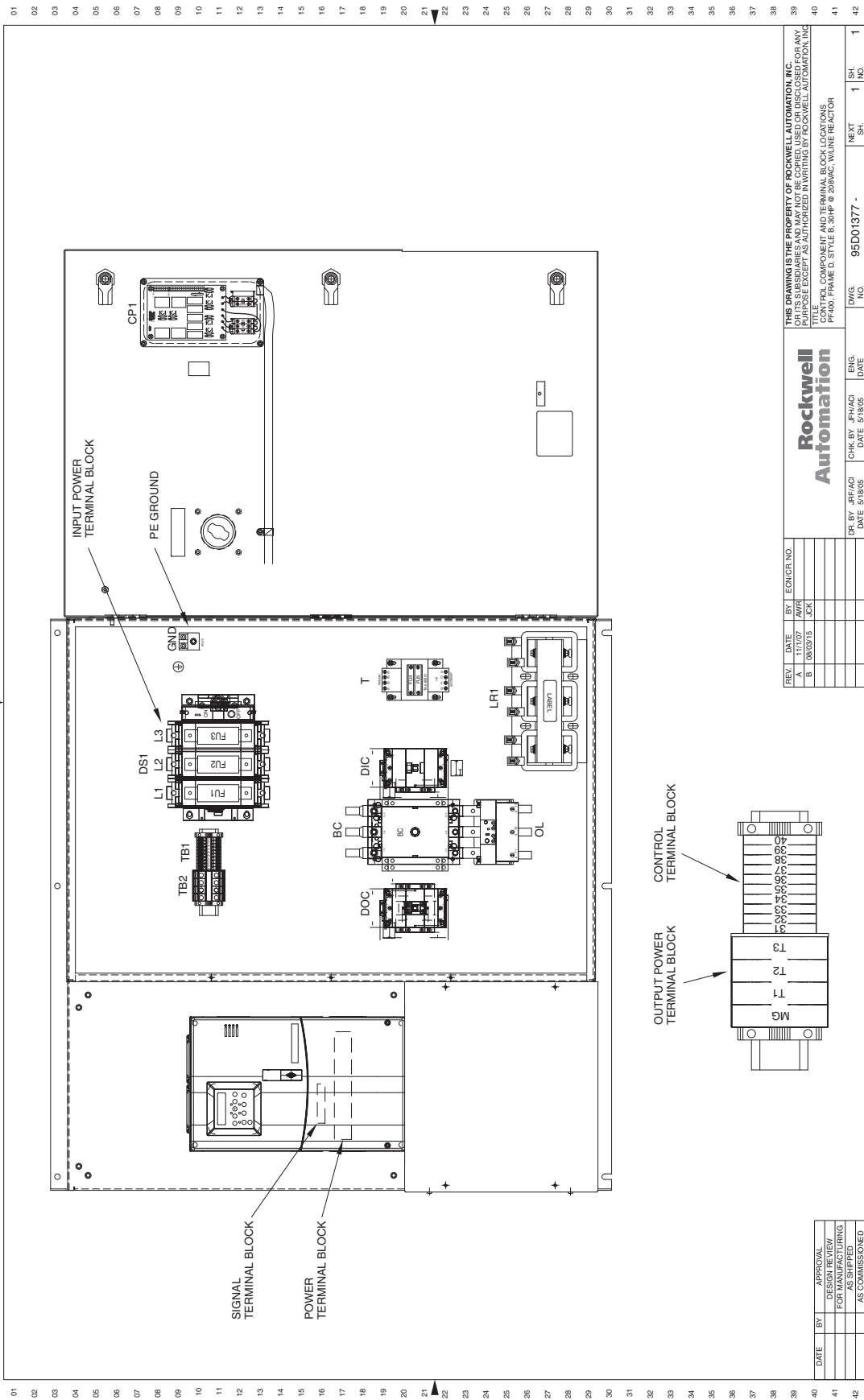

Figure 104 - 50...60 Hp, 460V AC Drives with Line Reactor - NEMA/UL Type 1

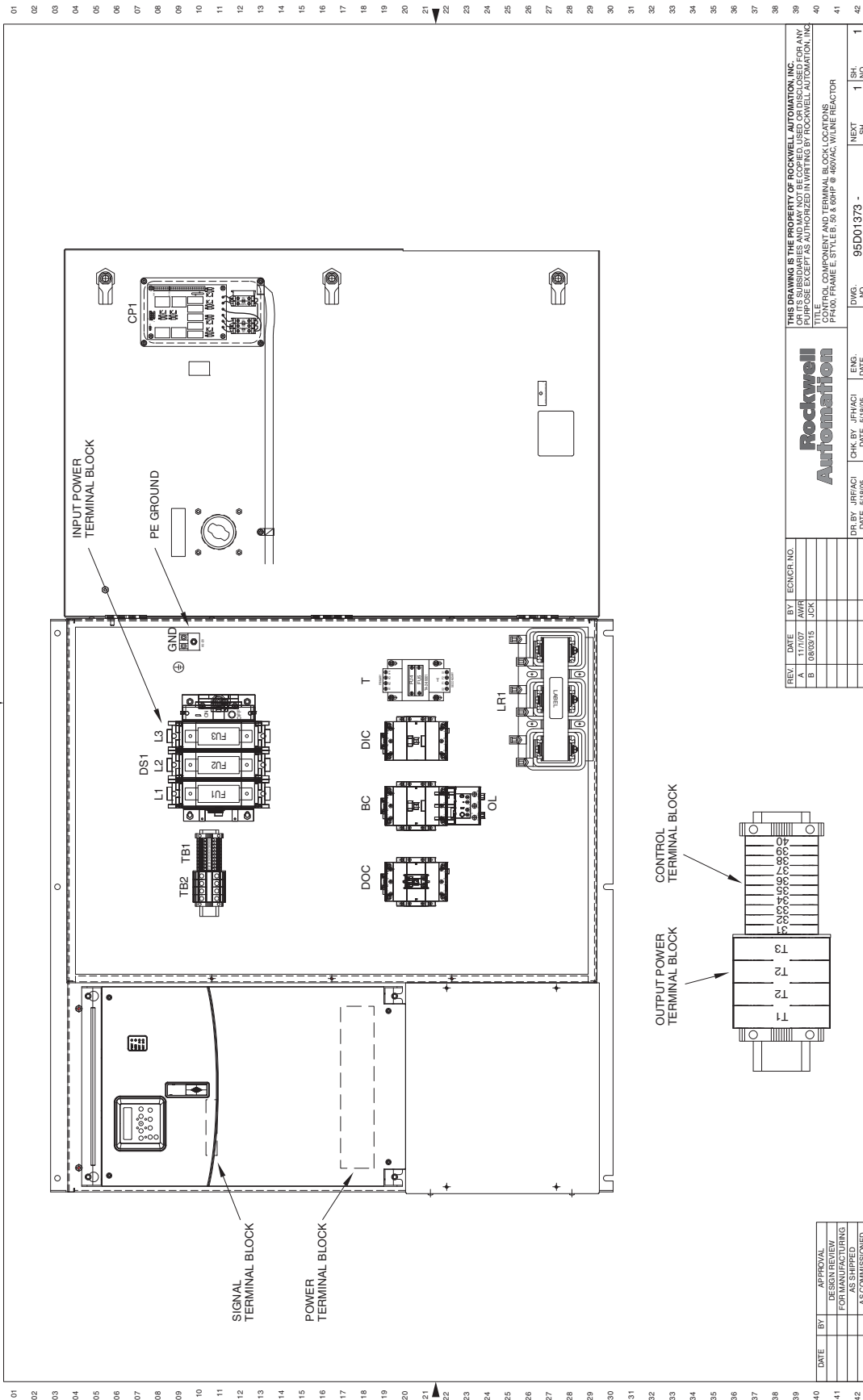
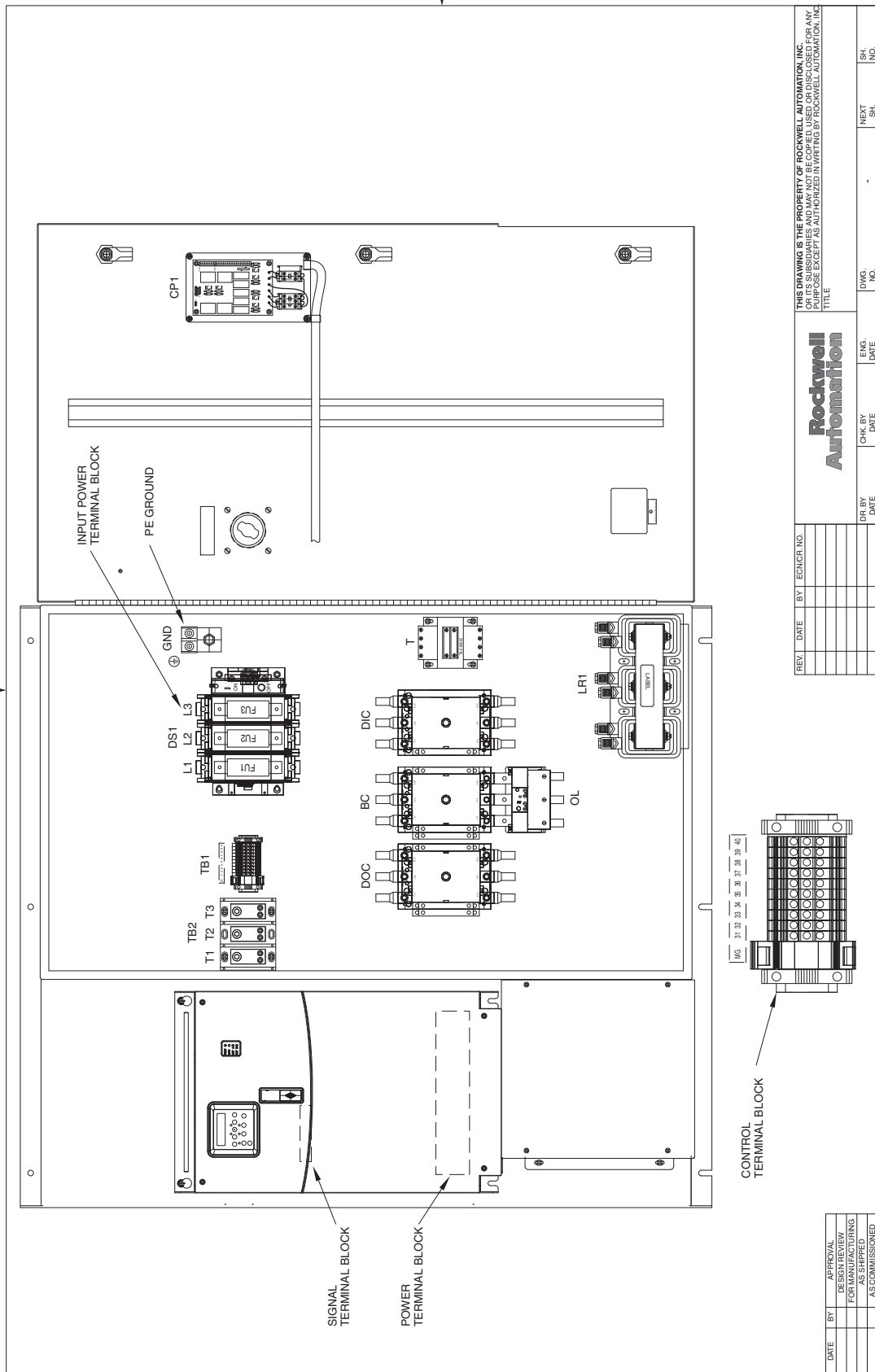

Figure 105 - 40...50 Hp, 208V AC and 75...100 Hp, 460V AC Drives with Line Reactor - NEMA/UL Type 1



THIS DRAWING IS THE PROPERTY OF ROCKWELL AUTOMATION, INC. FOR ANY PURPOSE EXCEPT AS AUTHORIZED IN WRITING BY ROCKWELL AUTOMATION, INC.

Rockwell Automation

REV.	DATE	BY	ECNCR. NO.	DES. BY	DATE	CHK. BY	DATE	ENG. DATE	DES. NO.	REV. INCL.

DATE	BY	APPROVAL
		DESIGN REVIEW
		FOR MANUFACTURING
		AS COMMISSIONED

Figure 106 - 3.0...10 Hp, 208V AC and 3.0...20 Hp, 460V AC Drives - NEMA/UL Type 12

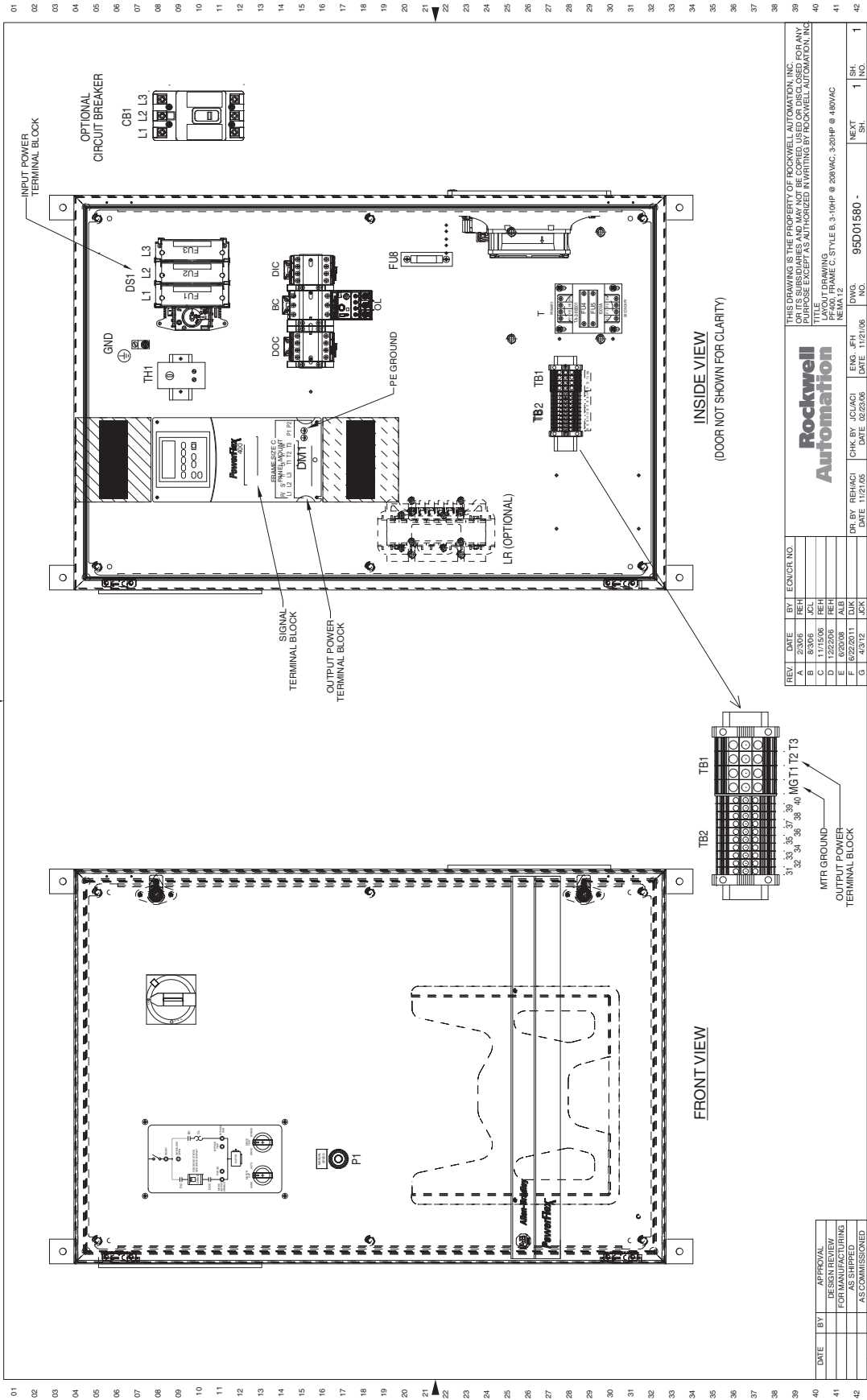

REV	DATE	BY	ECN/CR NO.	REH	JCK
A	2/20/08	REH			
B	8/20/08	JCK			
C	11/22/08	REH			
D	1/22/2008	REH			
E	6/20/09	ALB			
F	6/22/2011	DIK			
G	4/23/12	JCK			

DR. BY REH/ACI	CHK BY JG/LACI	ENG. JFH	DWG. NO.	95D01580 -	NO.	1	SH.	1	NO.	1
DATE 11/21/06	DATE 02/23/06	DATE 11/21/06								

DATE	BY	APPROVAL
		DESIGN REVIEW
		FOR MANUFACTURING
		AS SHIPPED
		AS COMMISSIONED

THIS DRAWING IS THE PROPERTY OF ROCKWELL AUTOMATION, INC. OR ITS SUBSIDIARIES AND MAY NOT BE COPIED, USED OR DISCLOSED FOR ANY PURPOSES WITHOUT THE WRITTEN PERMISSION OF ROCKWELL AUTOMATION, INC.

TITLE: LAYOUT DRAWING
 PART NUMBER: FRAME C, STYLE B, 3.0HP @ 208VAC, 3.0HP @ 480VAC
 NEMA 12

Rockwell Automation

REV | DATE | BY | ECN/CR NO. | REH | JCK

TB1
 TB2
 31, 33, 35, 37, 39, 40, MG11, T2, T3
 MTR GROUND
 OUTPUT POWER
 TERMINAL BLOCK

INSIDE VIEW
 (DOOR NOT SHOWN FOR CLARITY)

FRONT VIEW

Figure 107 - 15...20 Hp, 208V AC and 25...40 Hp, 460V AC Drives - NEMA/UL Type 12

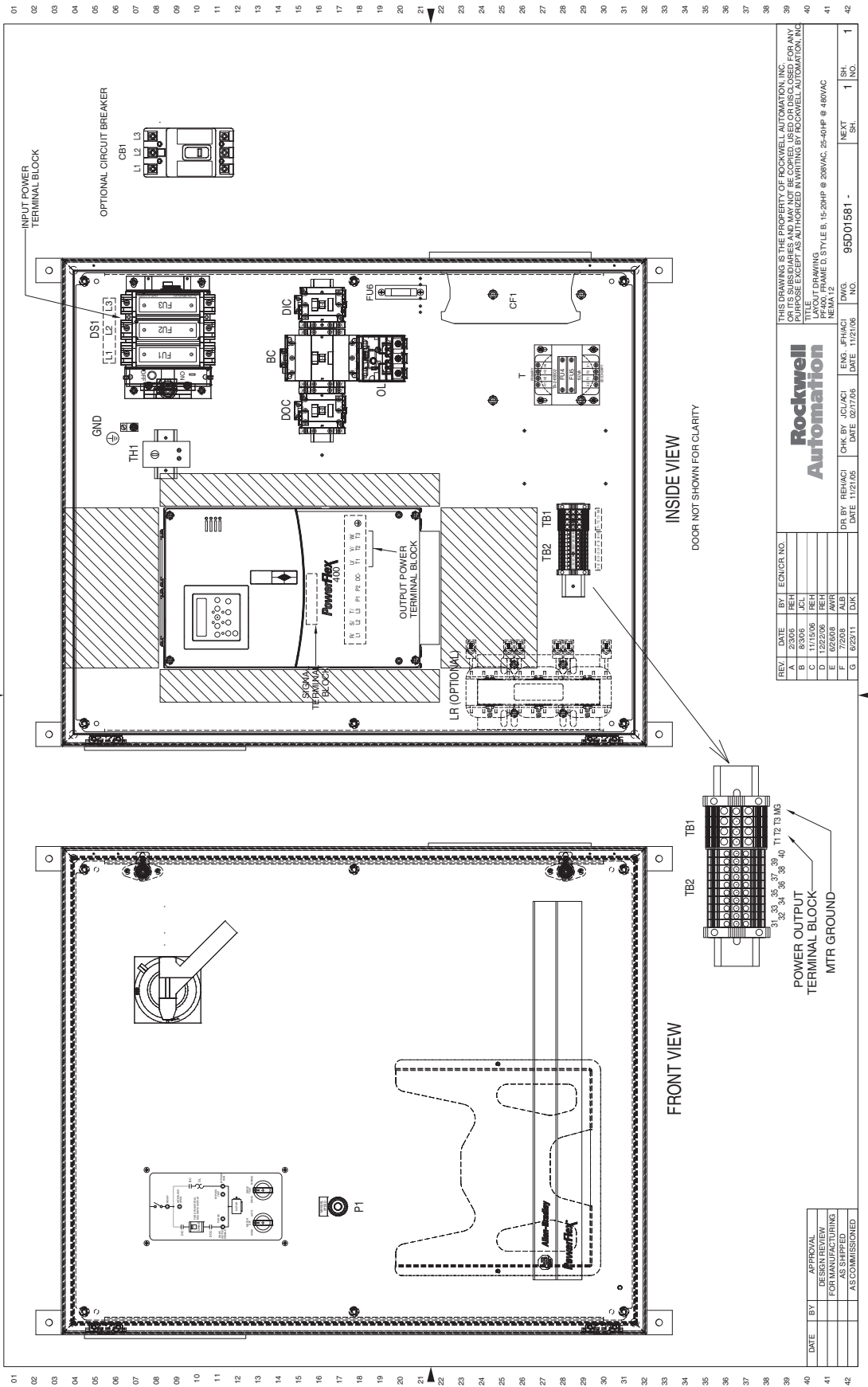

Figure 108 - 25...30 Hp, 208V AC and 50...60 Hp, 460V AC Drives - NEMA/UL Type 12

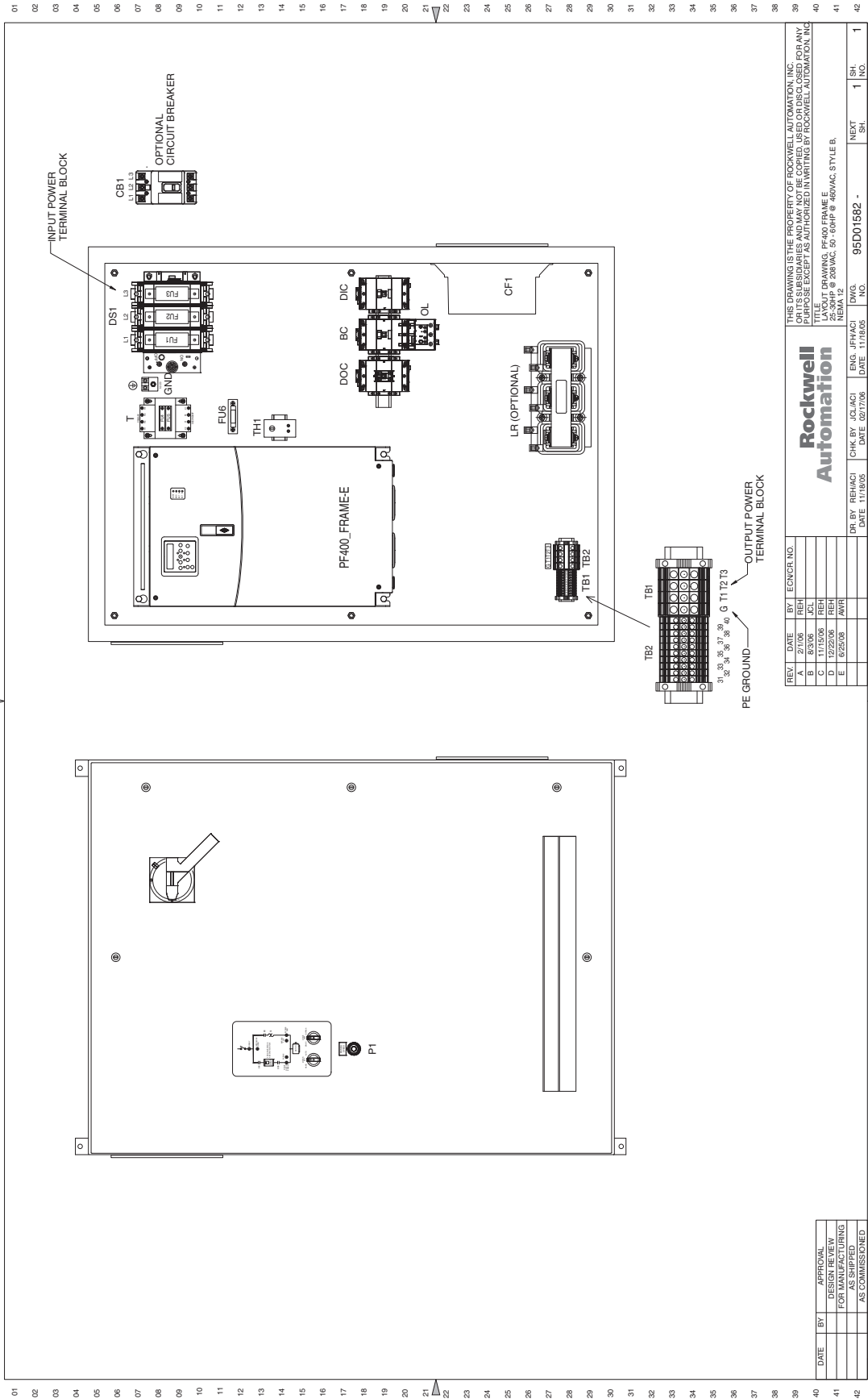
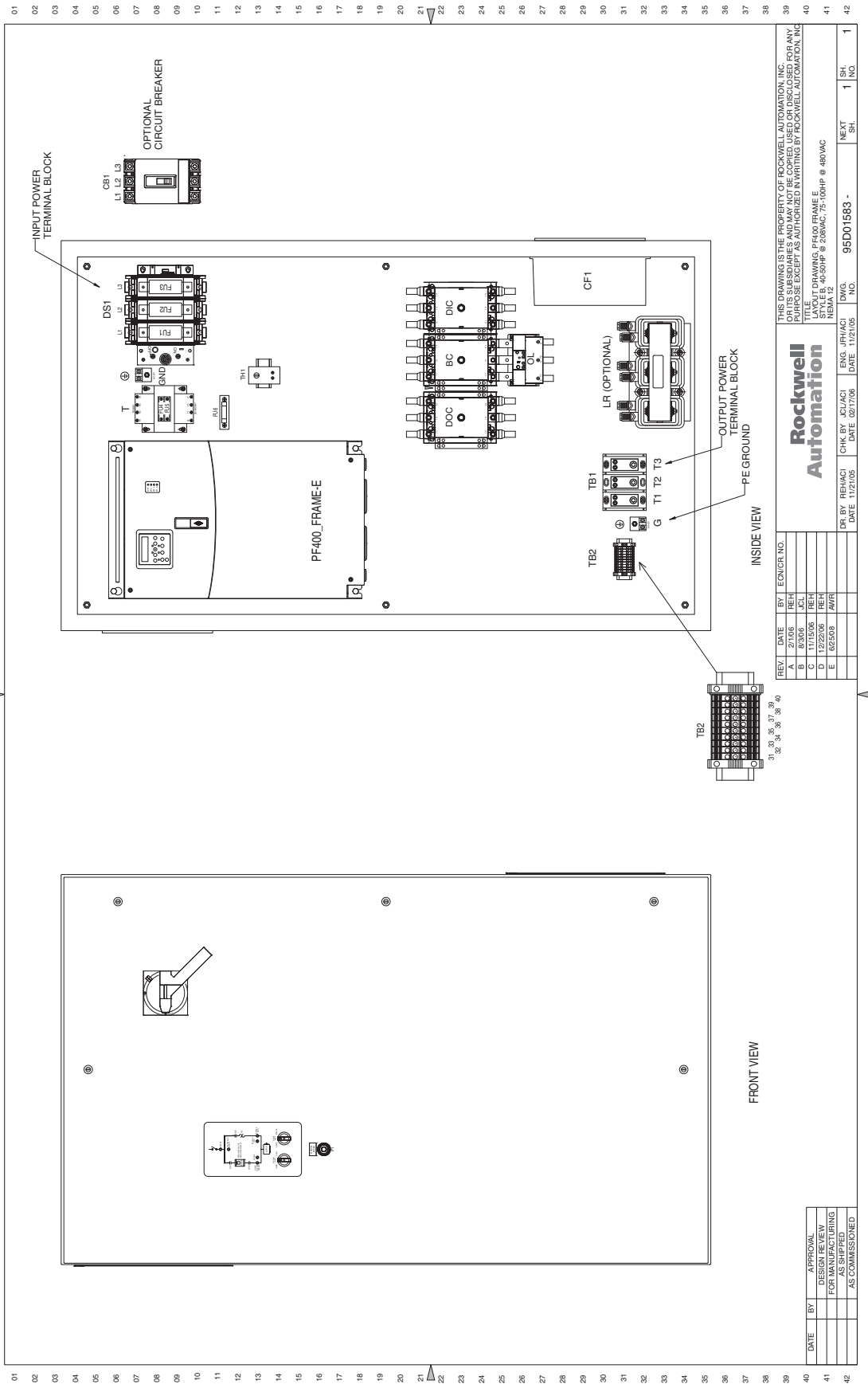

Figure 109 - 40...50 Hp, 208V AC and 75...100 Hp, 460V AC Drives - NEMA/UL Type 12



REV.	DATE	BY	ED/CR. NO.	DESCRIPTION
A	2/15/06	REH		
B	11/15/06	REH		
C	12/22/06	REH		
D	02/03/08	AVR		
E				

DR. BY	REMACI	CHK. BY	JL/ACI	ENG. JH/ACI	DATE	11/21/09	DWG. NO.	95D01583 -	REV.	1
									SH.	1
									SH.	1

THIS DRAWING IS THE PROPERTY OF ROCKWELL AUTOMATION, INC. FOR ANY PURPOSE EXCEPT AS AUTHORIZED IN WRITING BY ROCKWELL AUTOMATION, INC.

TITLE: DRAWING, PF400 FRAME
 STYLE: B, 40-50HP @ 208VAC, 75-100HP @ 460VAC
 NEMA 12

Figure 110 - 125...150 Hp, 460V AC Drives - NEMA/UL Type 12

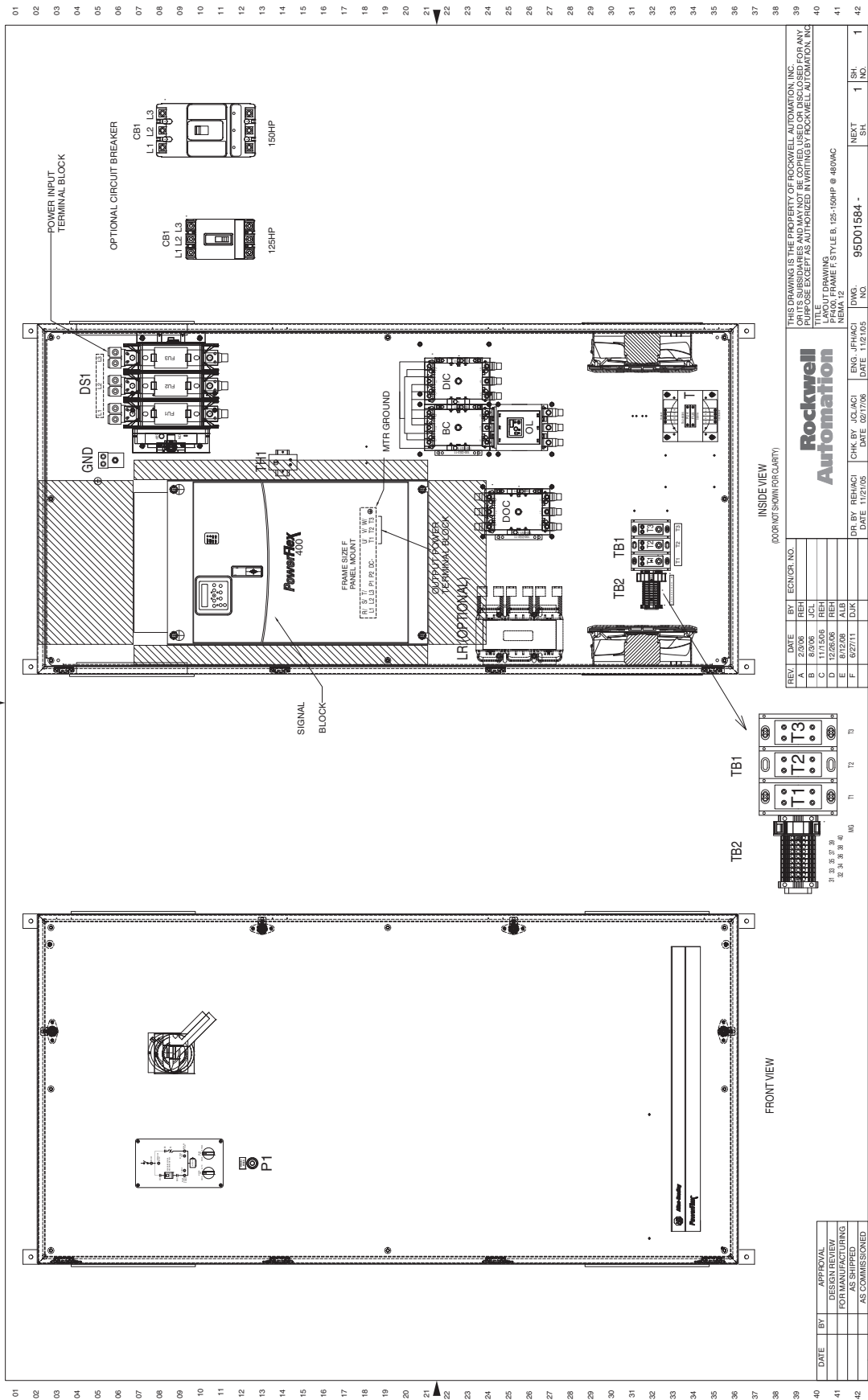
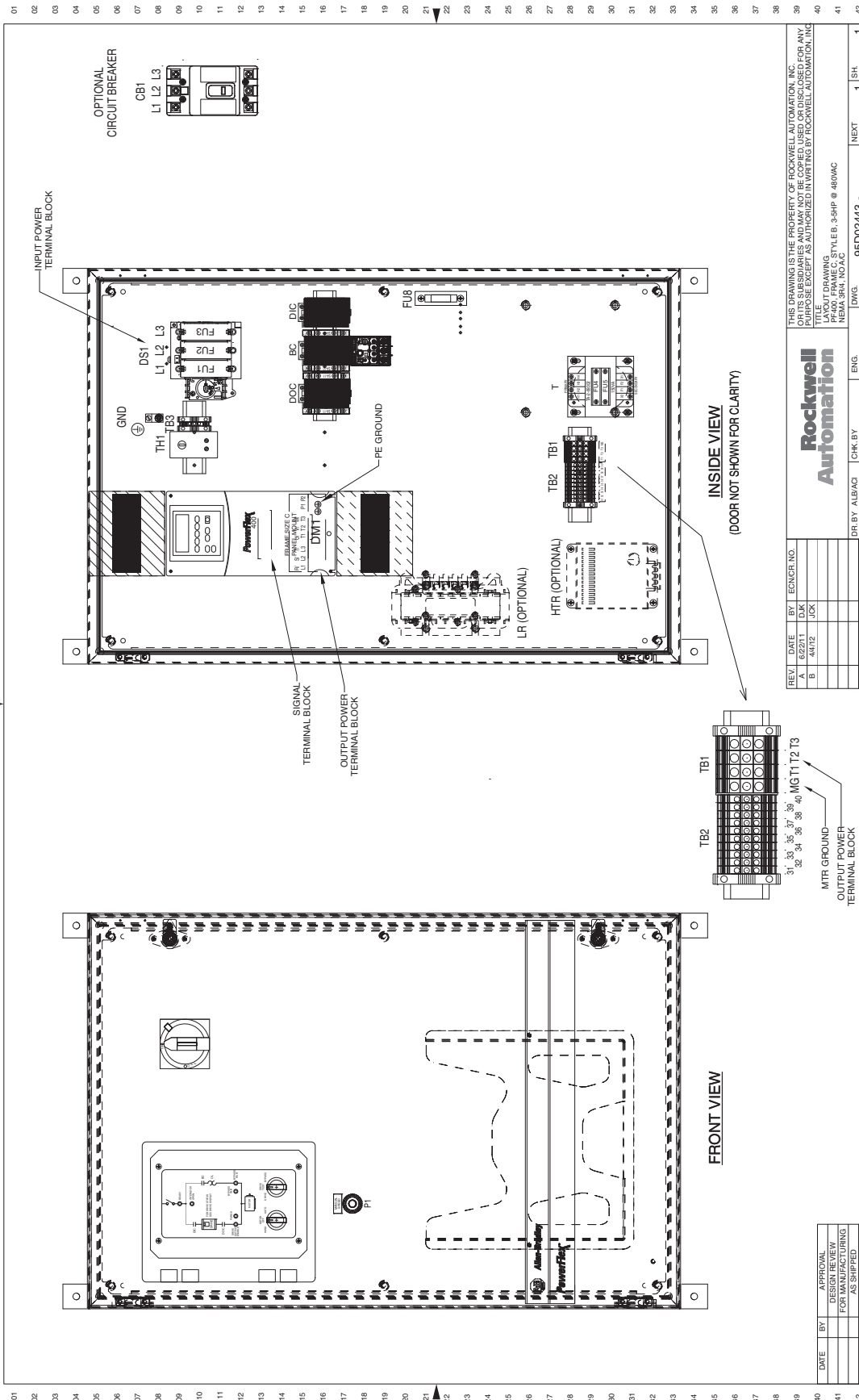

Figure 111 - 3.0...5.0 Hp, 460V AC Drives - NEMA/UL Type 4



REV.	DATE	BY	ECNR NO.
A	8/22/11	DK	
B	4/17/12	JK	

THIS DRAWING IS THE PROPERTY OF ROCKWELL AUTOMATION, INC. FOR ANY PURPOSE EXCEPT AS AUTHORIZED IN WRITING BY ROCKWELL AUTOMATION, INC.

Rockwell Automation

TITLE: DRAWING
 PART: PF460 FRAME C, STYLE: B, 3.5HP @ 460VAC
 NEMA 3R4, NO AC

DR. BY: ALBACI DATE: 7/7/08

CHK. BY: DATE:

ENG. DATE:

DWG. NO. 95D02443

SHEET NO. 1

DATE	BY	APPROVAL
		DESIGN REVIEW FOR MANUFACTURING AS SHIPPED
		AS COMMISSIONED

Figure 112 - 3.0...10 Hp, 208V AC and 7.5...20 Hp, 460V AC Drives - NEMA/UL Type 4

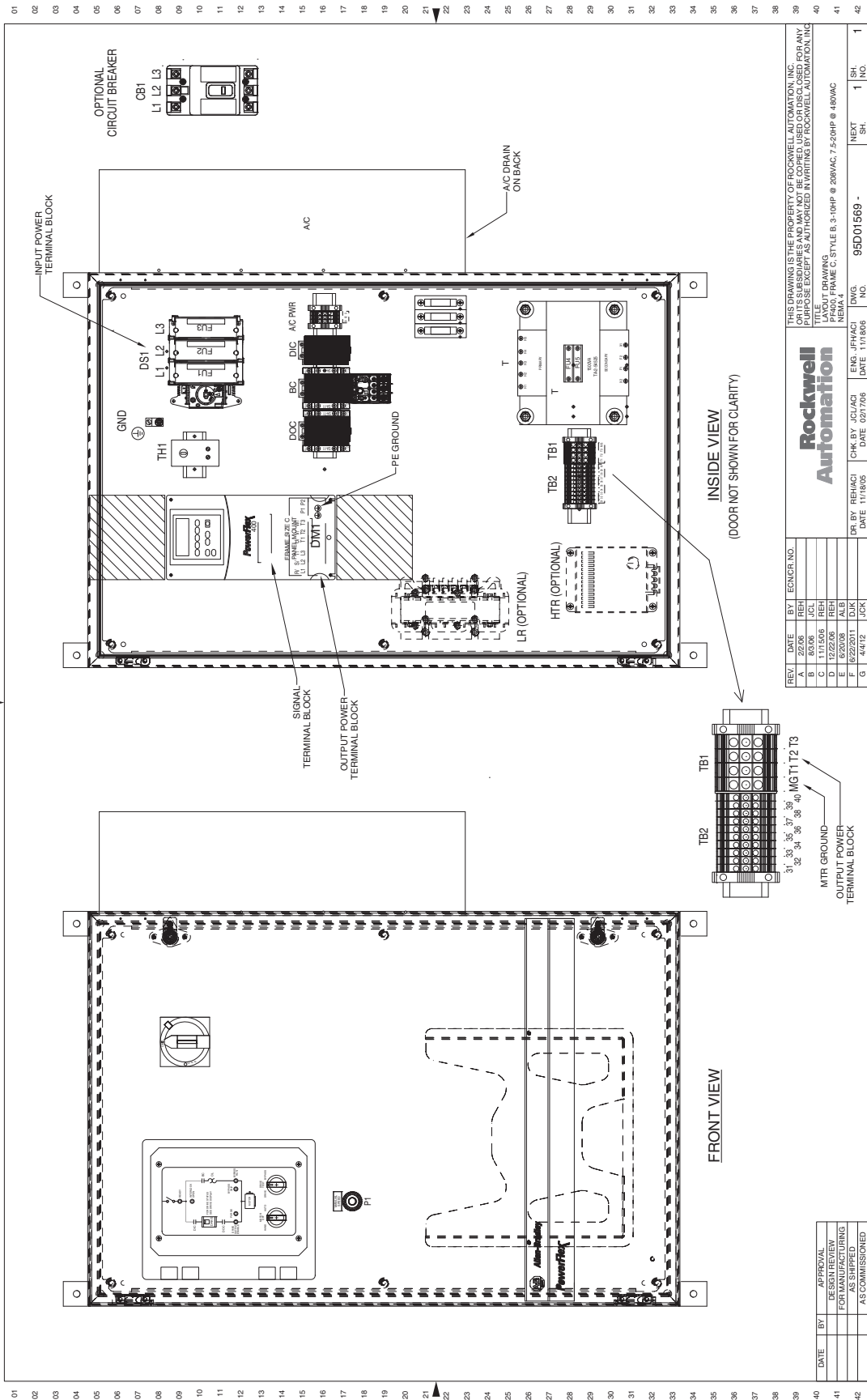

Figure 113 - 15...20 Hp, 208V AC and 25...40 Hp, 460V AC Drives - NEMA/UL Type 4

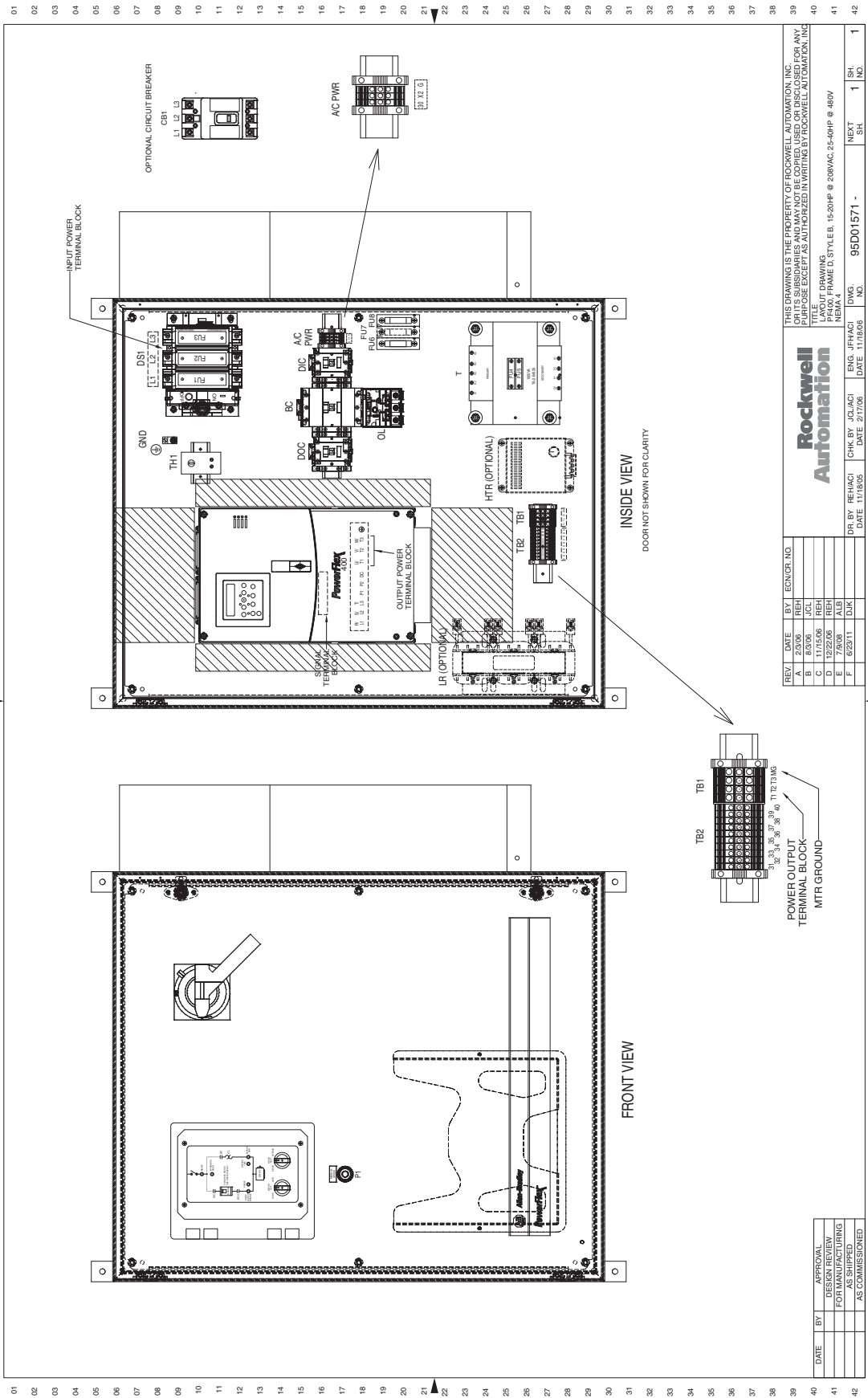
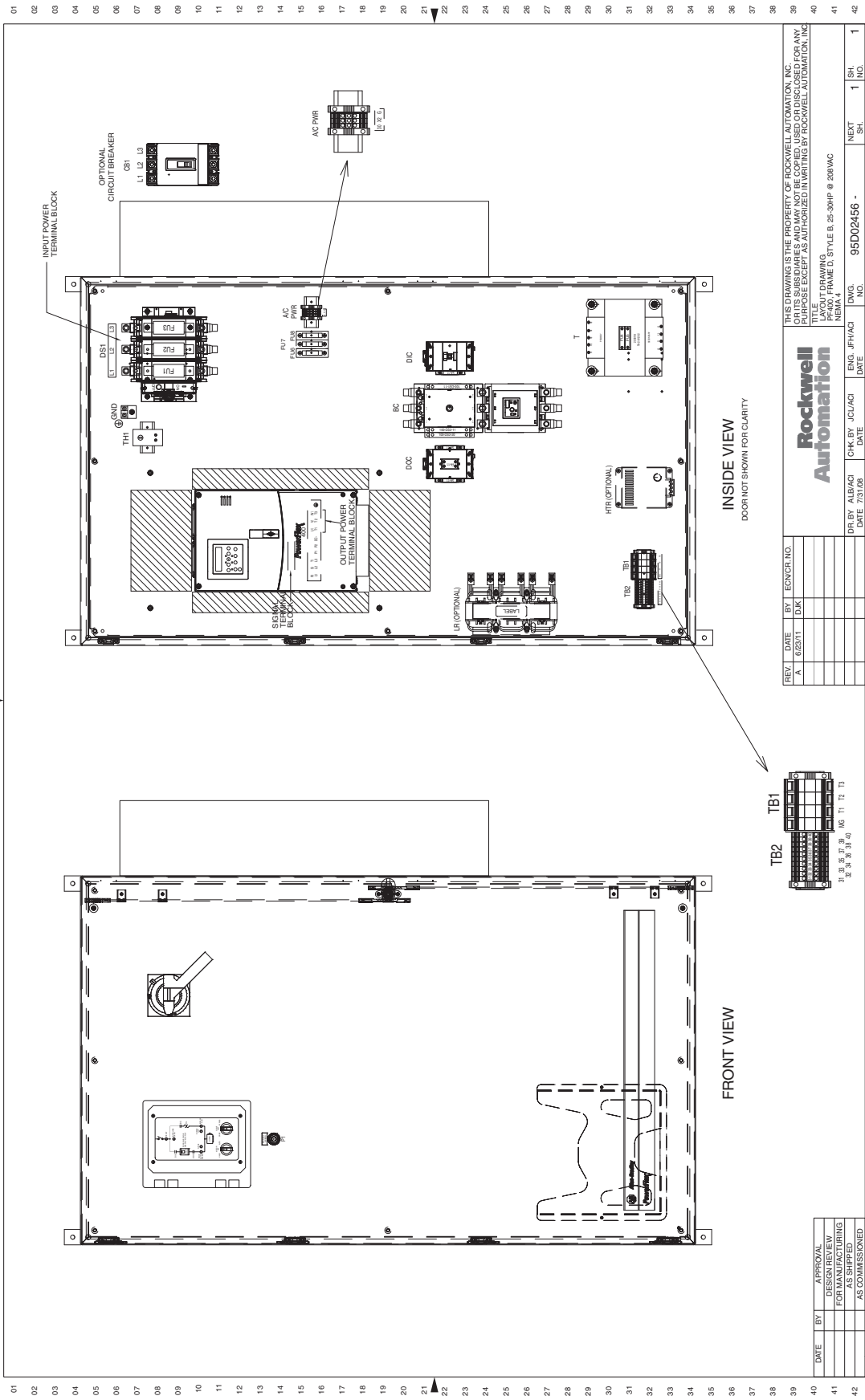

Figure 114 - 25...30 Hp, 208V AC Drives - NEMA/UL Type 4



REV.	DATE	BY	ECNCR. NO.	THIS DRAWING IS THE PROPERTY OF ROCKWELL AUTOMATION, INC. OR ITS SUBSIDIARIES AND MAY NOT BE COPIED, USED OR DISCLOSED FOR ANY PURPOSES EXCEPT AS AUTHORIZED IN WRITING BY ROCKWELL AUTOMATION, INC.			
A	6/23/11	D.K.		TITLE			
LAYOUT DRAWING				PART NAME B, STYLE B, 25-30HP @ 208VAC			
				NEMA 4			
				DWG. NO.			
				95D02456			
				DATE			
				NO.			
				1			
				SH.			
				NEXT			
				SH.			
				1			
				NO.			

DR. BY	ALB/ACI	DATE	7/31/08
CHK. BY	JCL/ACI	DATE	
ENG. JFH/ACI		DATE	

DATE	BY	APPROVAL
		DESIGN REVIEW
		FOR MANUFACTURING
		AS SHIPPED
		AS COMMISSIONED

Figure 115 - 40...50 Hp, 208V AC Drives - NEMA/UL Type 4

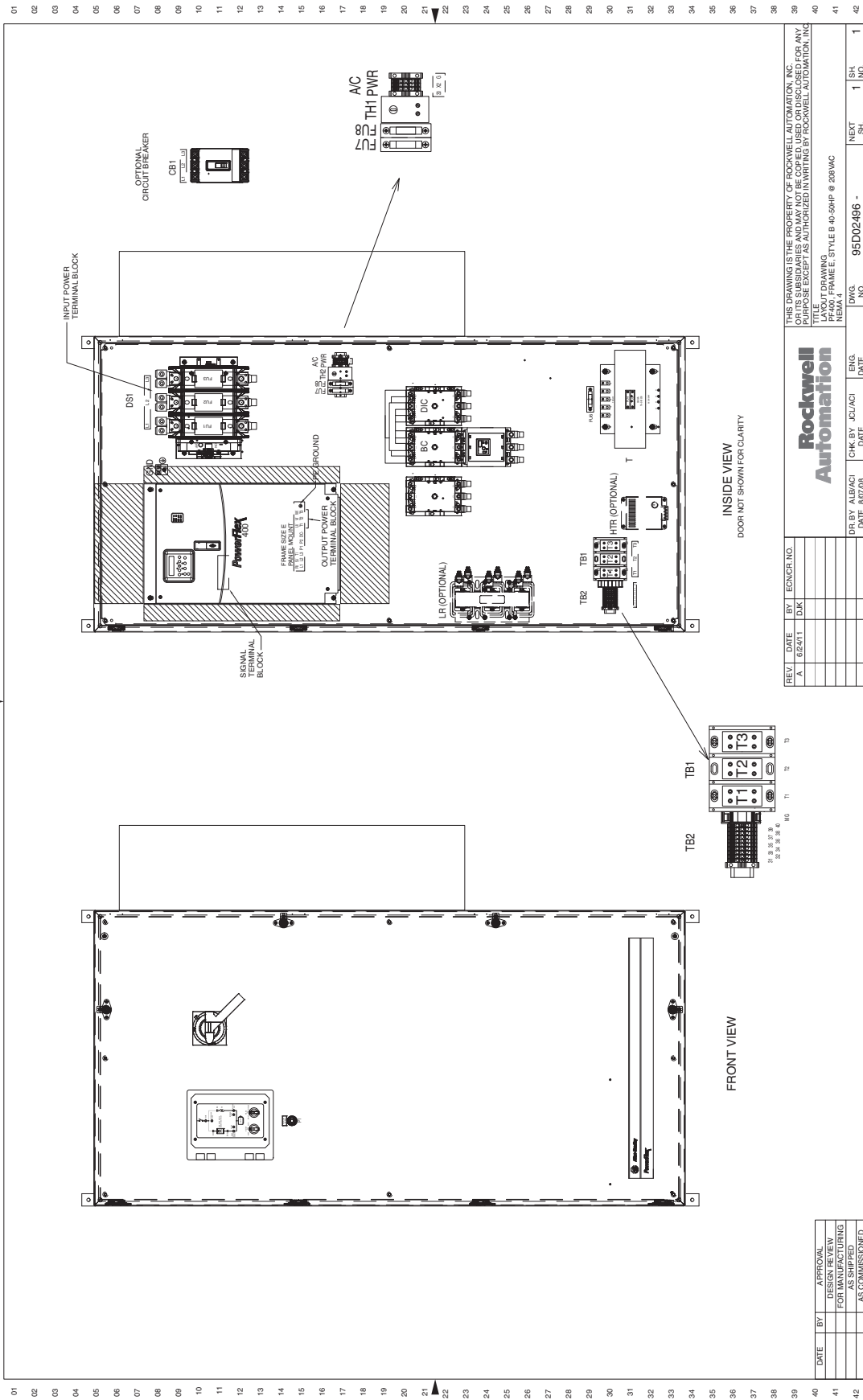

Figure 116 - 50...60 Hp, 460V AC Drives - NEMA/UL Type 4

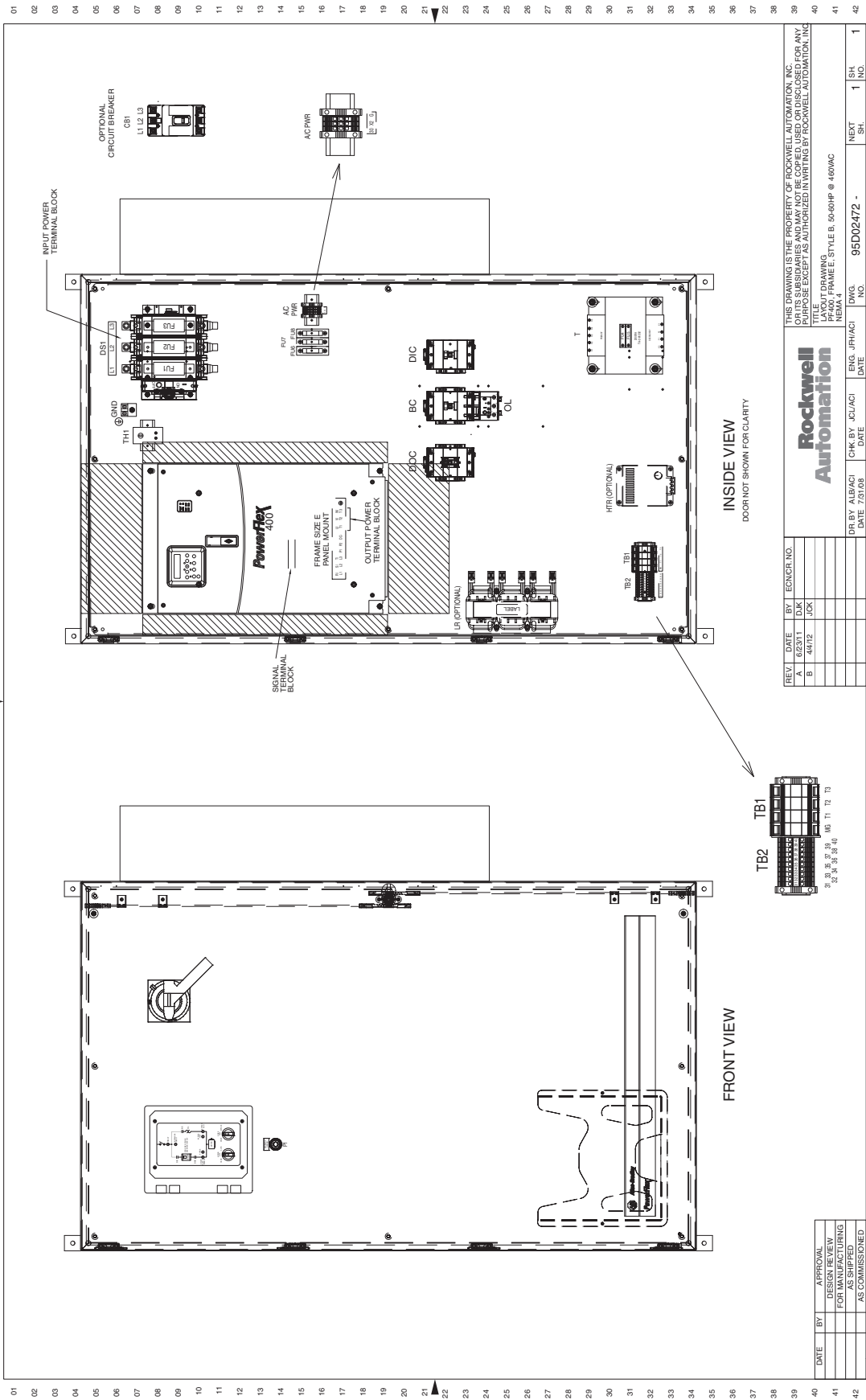

Figure 117 - 75...100 Hp, 460V AC Drives - NEMA/UL Type 4

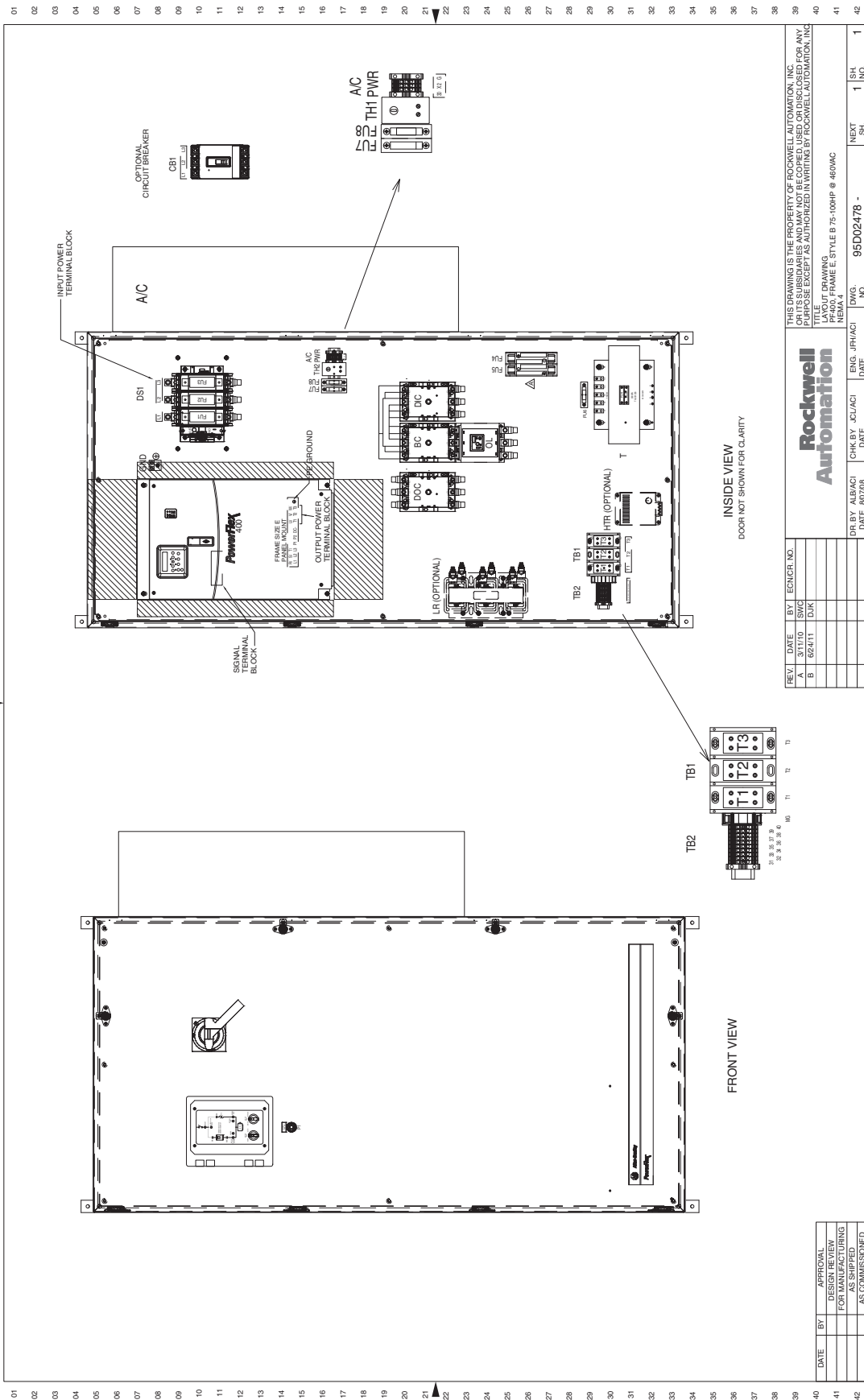
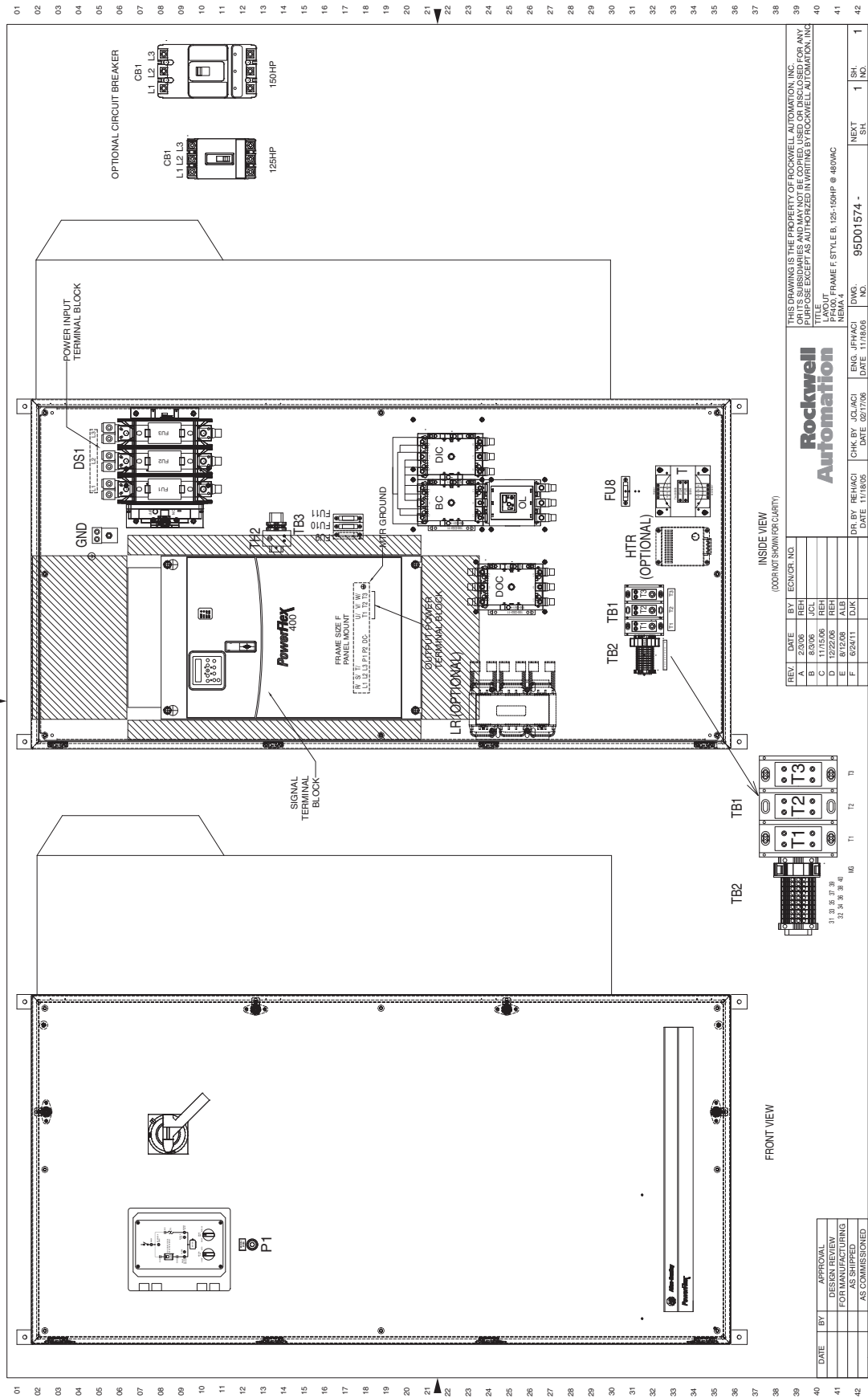

Figure 118 - 125...150 Hp, 460V AC Drives - NEMA/UL Type 4



REV	DATE	BY	ECN/CR. NO.
A	2/20/06	REH	
B	8/20/06	JCL	
C	12/22/06	REH	
D	12/22/06	REH	
E	8/12/08	AJB	
F	6/24/11	DLK	

Rockwell Automation			
THIS DRAWING IS THE PROPERTY OF ROCKWELL AUTOMATION, INC. OR ITS SUBSIDIARIES AND MAY NOT BE COPIED, USED, OR DISCLOSED FOR ANY PURPOSES WITHOUT THE WRITTEN AUTHORIZATION OF ROCKWELL AUTOMATION, INC.			
TITLE			
LAYOUT			
FRAME STYLE, E.B. 125-150HP @ 460VAC			
NEMA 4			
DR. BY	REH/ACI	CHK. BY	JCL/ACI
DATE	11/18/06	DATE	02/17/06
NO.	95D01574	DWG.	
1 SH.		1 SH.	
NO.		NO.	

DATE	BY	APPROVAL

DATE	BY	APPROVAL

DATE	BY	APPROVAL

DATE	BY	APPROVAL

DATE	BY	APPROVAL

DATE	BY	APPROVAL

Figure 120 - 15...20 Hp, 208V AC and 25...40 Hp, 460V AC Drives - NEMA/UL Type 3R

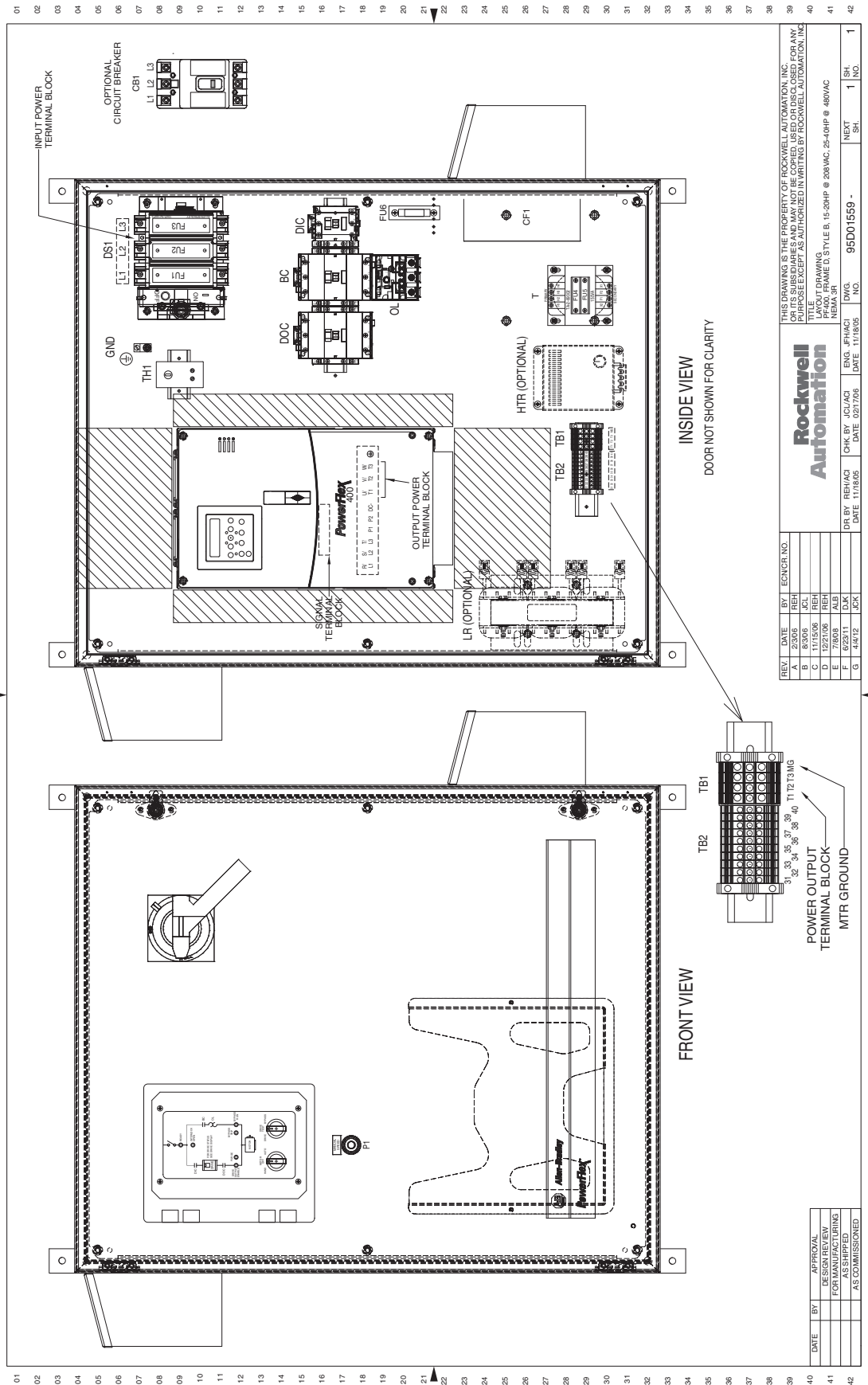

Figure 121 - 25...30 Hp, 208V AC Drives - NEMA/UL Type 3R

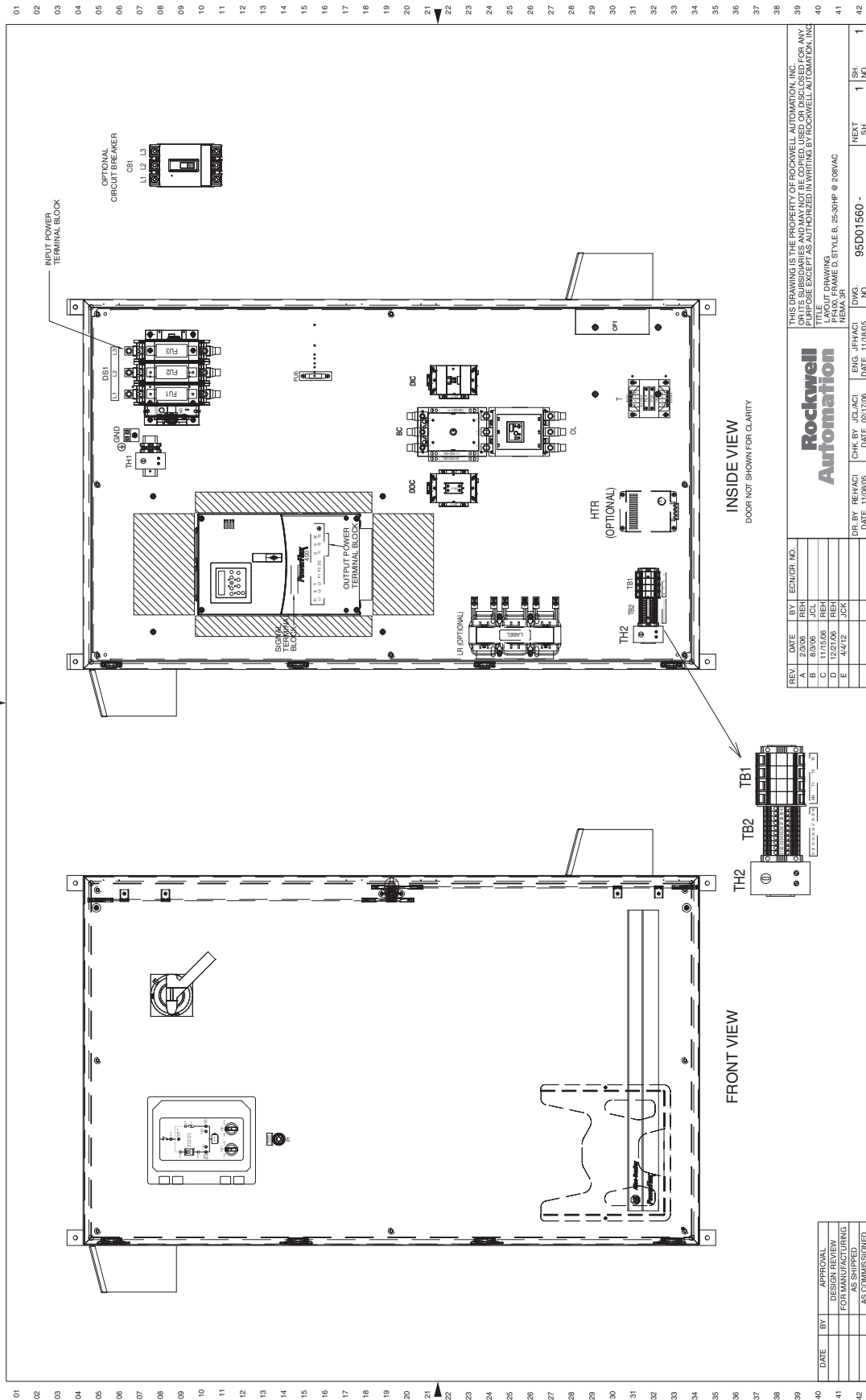
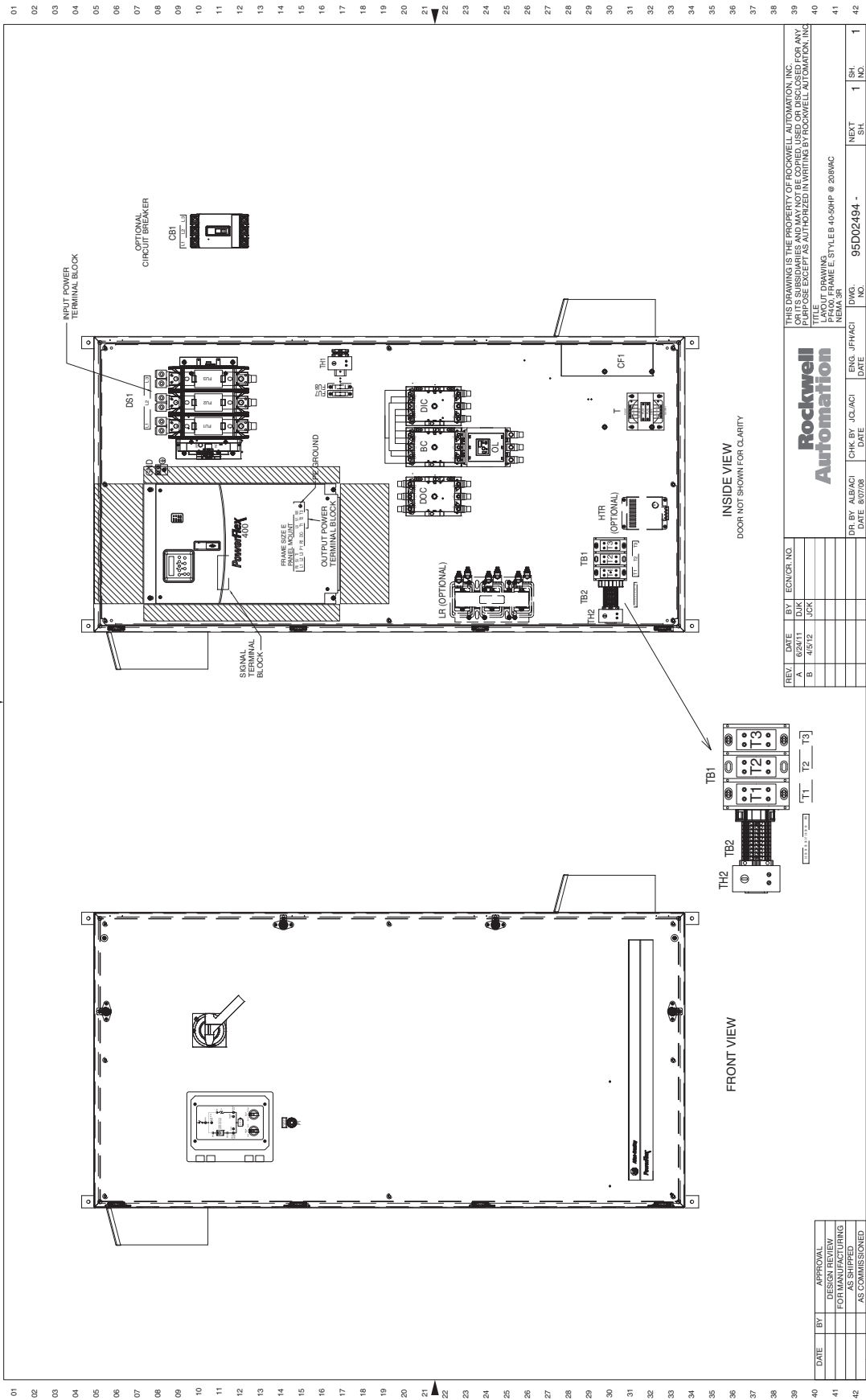

Figure 122 - 40...50 Hp, 208V AC Drives - NEMA/UL Type 3R



REV	DATE	BY	ECN/GR. NO.
A	6/24/11	DJK	
B	4/5/12	JCK	

DATE	BY	APPROVAL
		DESIGN REVIEW
		FOR MANUFACTURING
		AS SHIPPED
		AS COMMISSIONED

DR. BY	JG/AACI	DATE	ENG. JFH/AACI	DATE	DWG. NO.	NEXT SH.	1 SH.	NO.
					95D02494 -		1	1

THIS DRAWING IS THE PROPERTY OF ROCKWELL AUTOMATION, INC. OR ITS SUBSIDIARIES AND MAY NOT BE COPIED, USED, OR DISCLOSED FOR ANY PURPOSES WITHOUT THE WRITTEN PERMISSION OF ROCKWELL AUTOMATION, INC.

TITLE: LAYOUT DRAWING
 LAYOUT DRAWING
 NEMA 3R

01
02
03
04
05
06
07
08
09
10
11
12
13
14
15
16
17
18
19
20
21
22
23
24
25
26
27
28
29
30
31
32
33
34
35
36
37
38
39
40
41
42

Figure 123 - 50...60 Hp, 460V AC Drives - NEMA/UL Type 3R

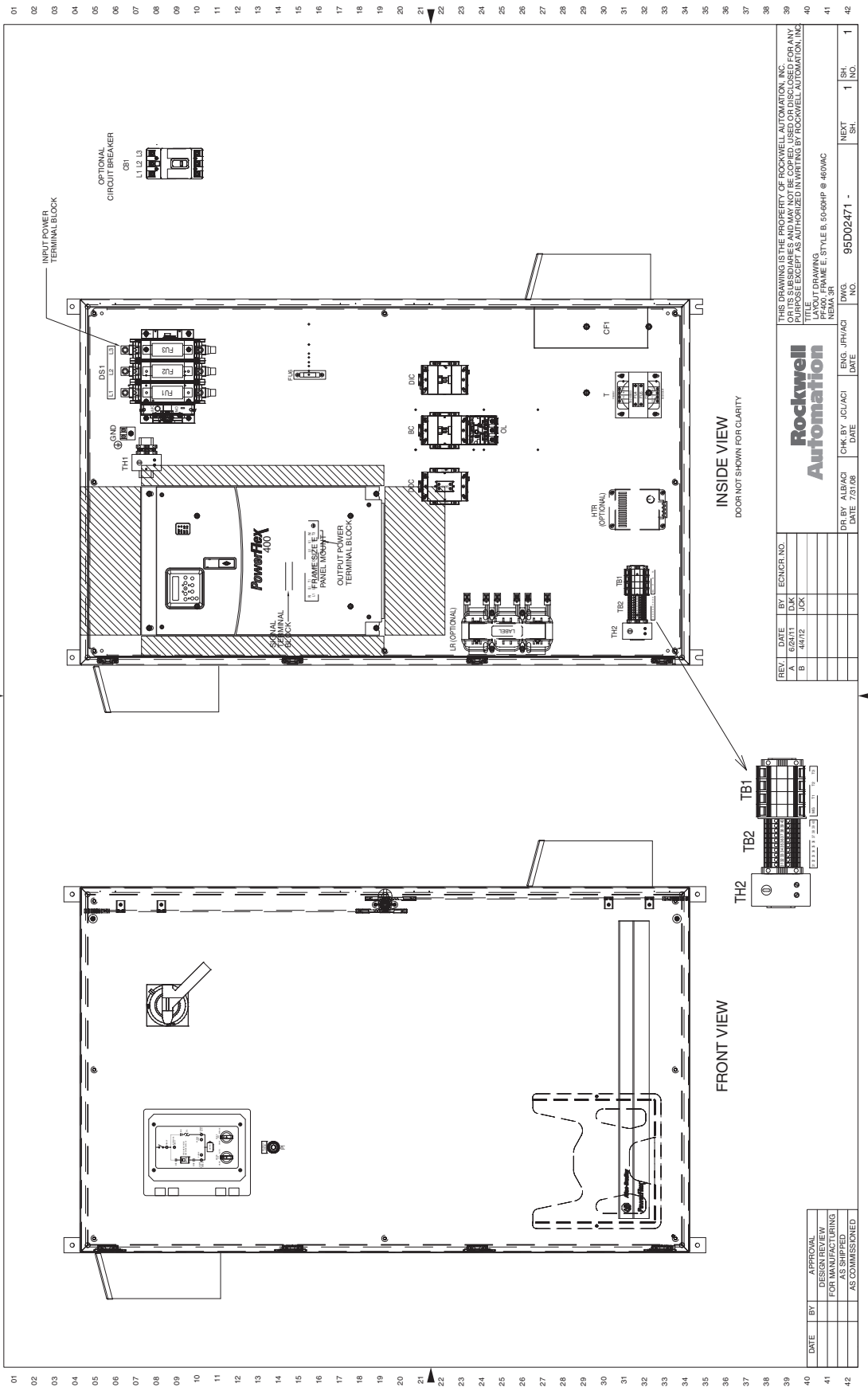

REV.	DATE	BY	ENGR. NO.
A	5/24/11	DK	
B	4/17/12	JCK	

DR BY	ALB/ACI	DATE	7/25/08
CHK BY	JG/JACI	DATE	
ENG	JH/ACI	DATE	
DWG.	NO.	DATE	
	95D02471 -		
		NEXT SH.	1
		NO.	1

THIS DRAWING IS THE PROPERTY OF ROCKWELL AUTOMATION, INC. IT IS NOT TO BE REPRODUCED OR TRANSMITTED IN ANY FORM OR BY ANY MEANS, ELECTRONIC OR MECHANICAL, INCLUDING PHOTOCOPYING, RECORDING, OR BY ANY INFORMATION STORAGE AND RETRIEVAL SYSTEM, WITHOUT THE WRITTEN PERMISSION OF ROCKWELL AUTOMATION, INC.

TITLE: TYPICAL DRAWING
 PF400, FRAME E, STYLE B, 50-60HP @ 460VAC
 NEMA 3R

DATE	BY	APPROVAL
		DESIGN REVIEW FOR MANUFACTURING AS SHIPPED AS COMMISSIONED

Figure 124 - 75...100 Hp, 460V AC Drives - NEMA/UL Type 3R

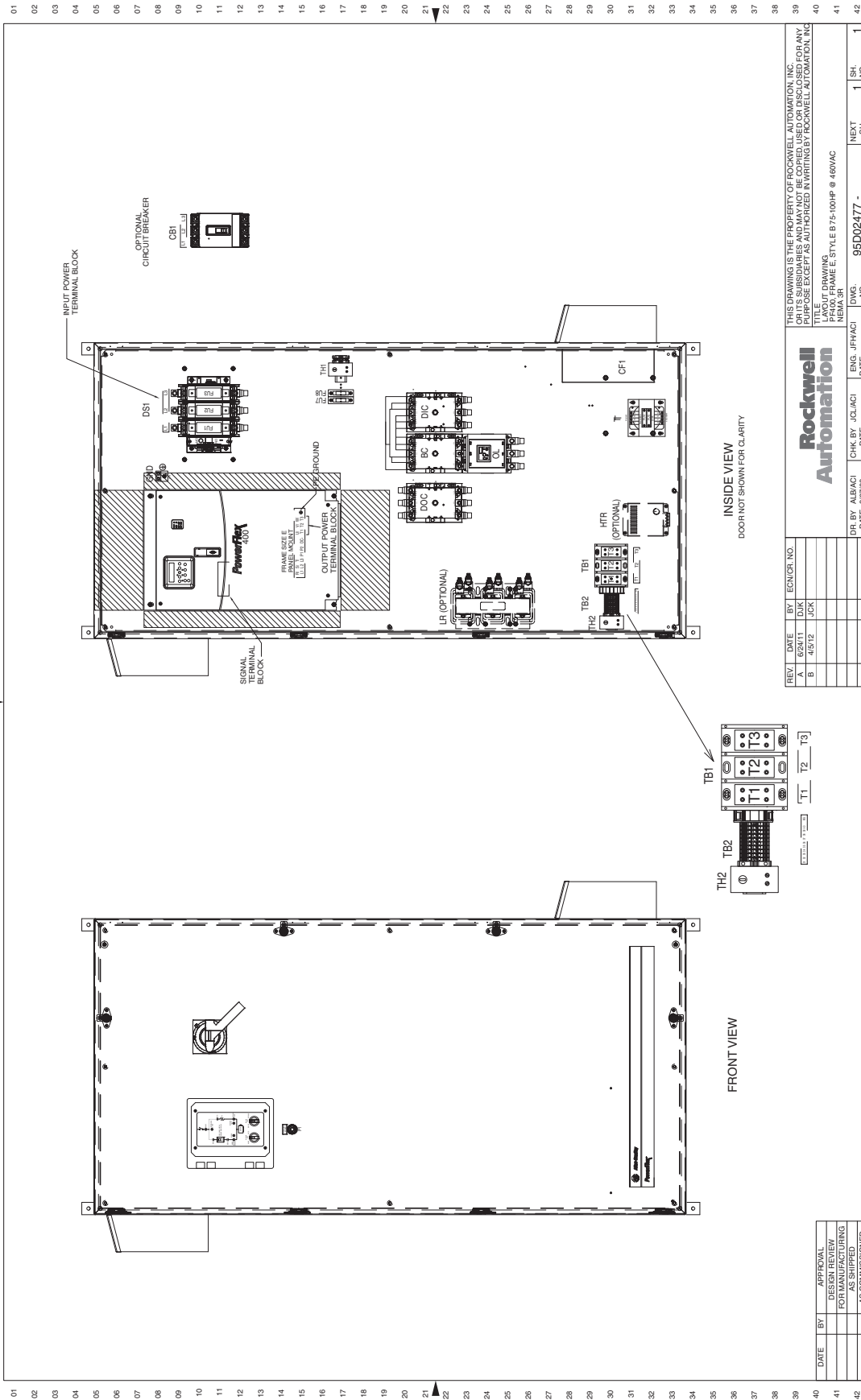

REV.	DATE	BY	ECN/CR. NO.	THIS DRAWING IS THE PROPERTY OF ROCKWELL AUTOMATION, INC. OR ITS SUBSIDIARIES AND MAY NOT BE COPIED, USED OR DISCLOSED FOR ANY PURPOSES EXCEPT AS AUTHORIZED IN WRITING BY ROCKWELL AUTOMATION, INC.										
A	6/24/11	DJK		TITLE LAYOUT DRAWING FRAME B, STYLE B 75-100HP @ 460VAC										
B	4/5/12	JCK												
DR. BY	ALB/ACI	DATE	CHK. BY	JCL/ACI	DATE	ENG.	JFH/ACI	DATE	DWG. NO.	95D02477 -	NEXT SH.	1	SH. NO.	1
DATE		BY		APPROVAL		DATE								
				DESIGN REVIEW										
				FOR MANUFACTURING										
				AS SHIPPED										
				AS COMMISSIONED										

Figure 125 - 125...150 Hp, 460V AC Drives - NEMA/UL Type 3R

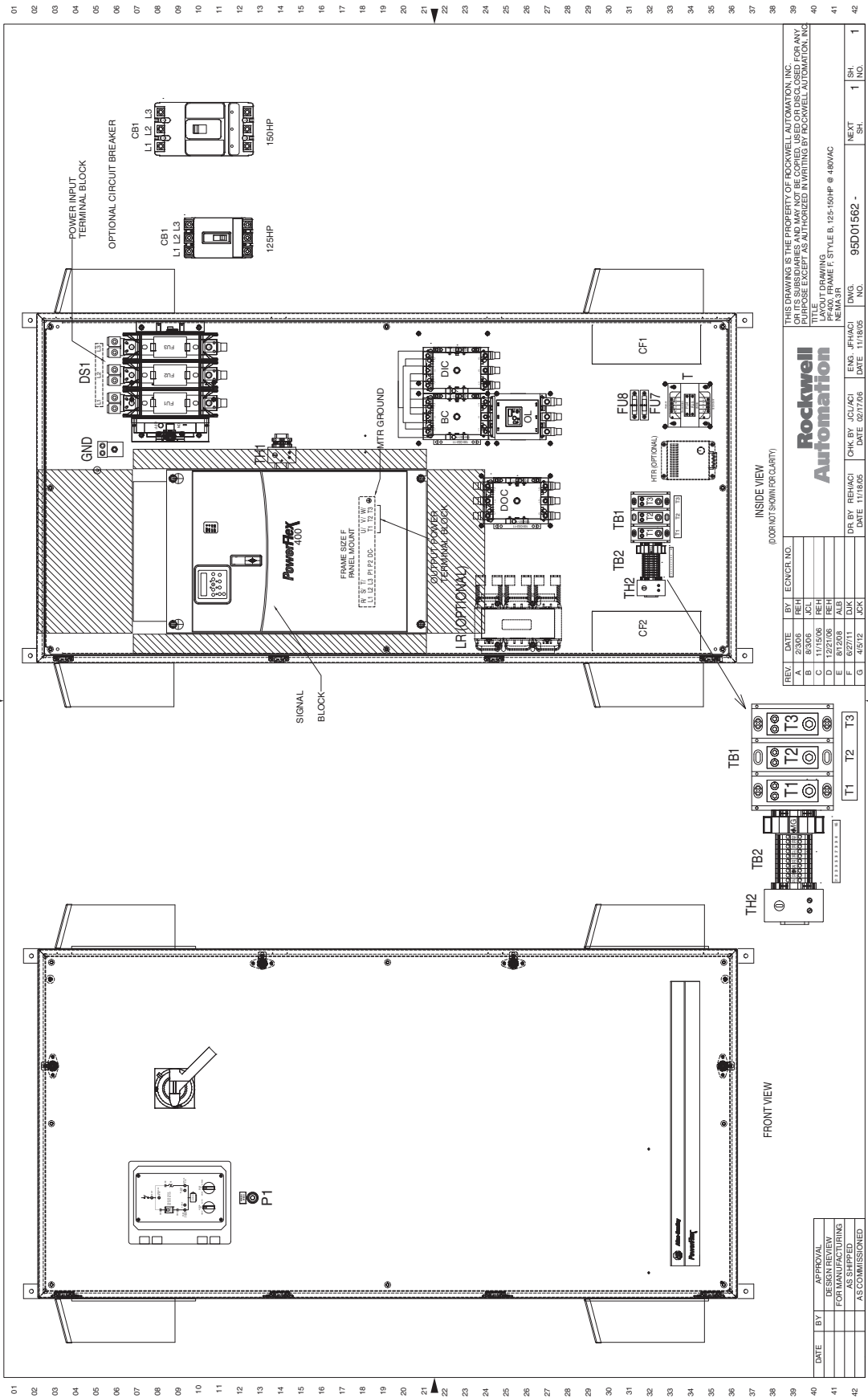

Outline Drawings

Figure 126 - 3.0...5.0 Hp, 208V AC and 3.0...10 Hp, 460V AC Drives - NEMA/UL Type 1

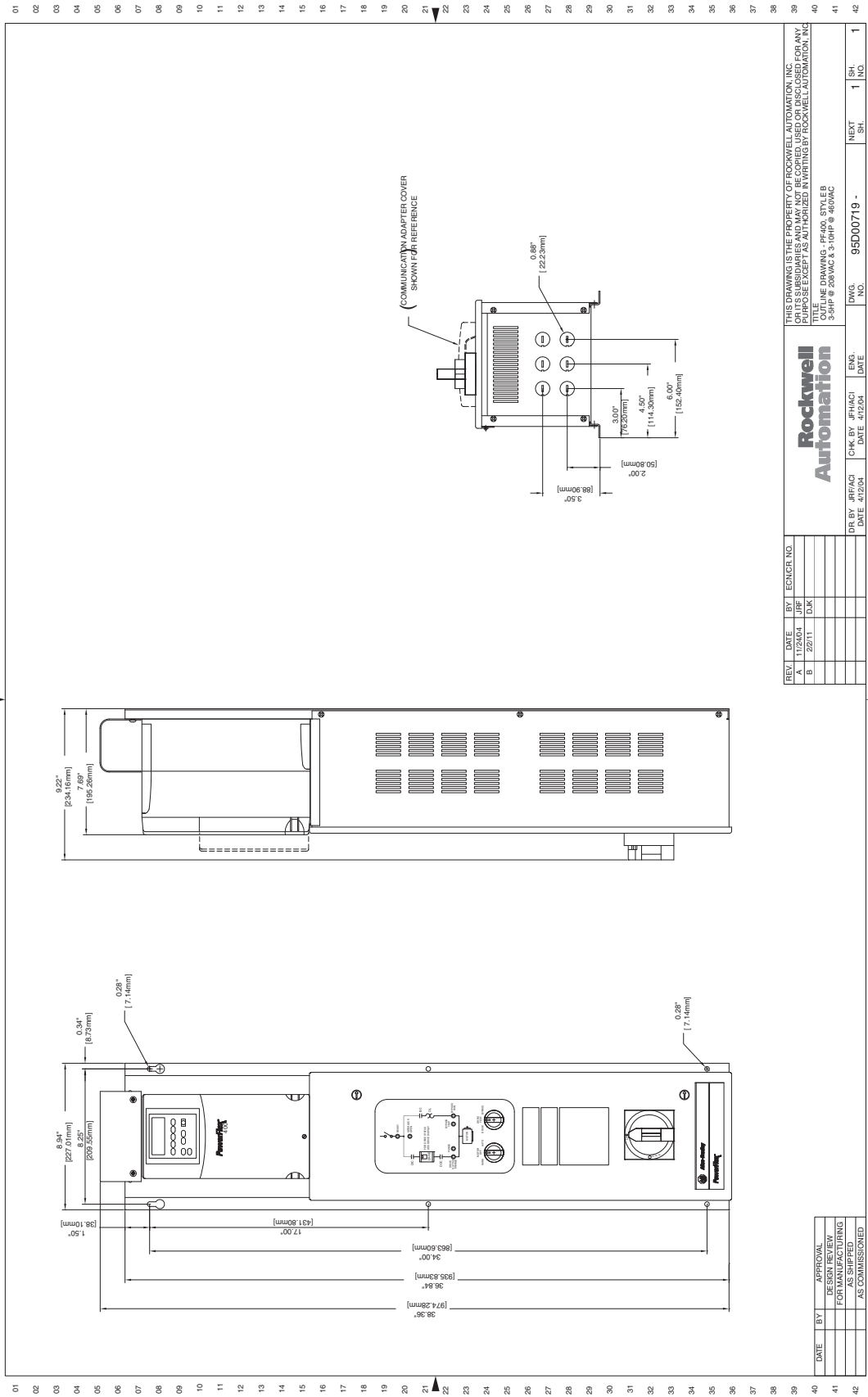
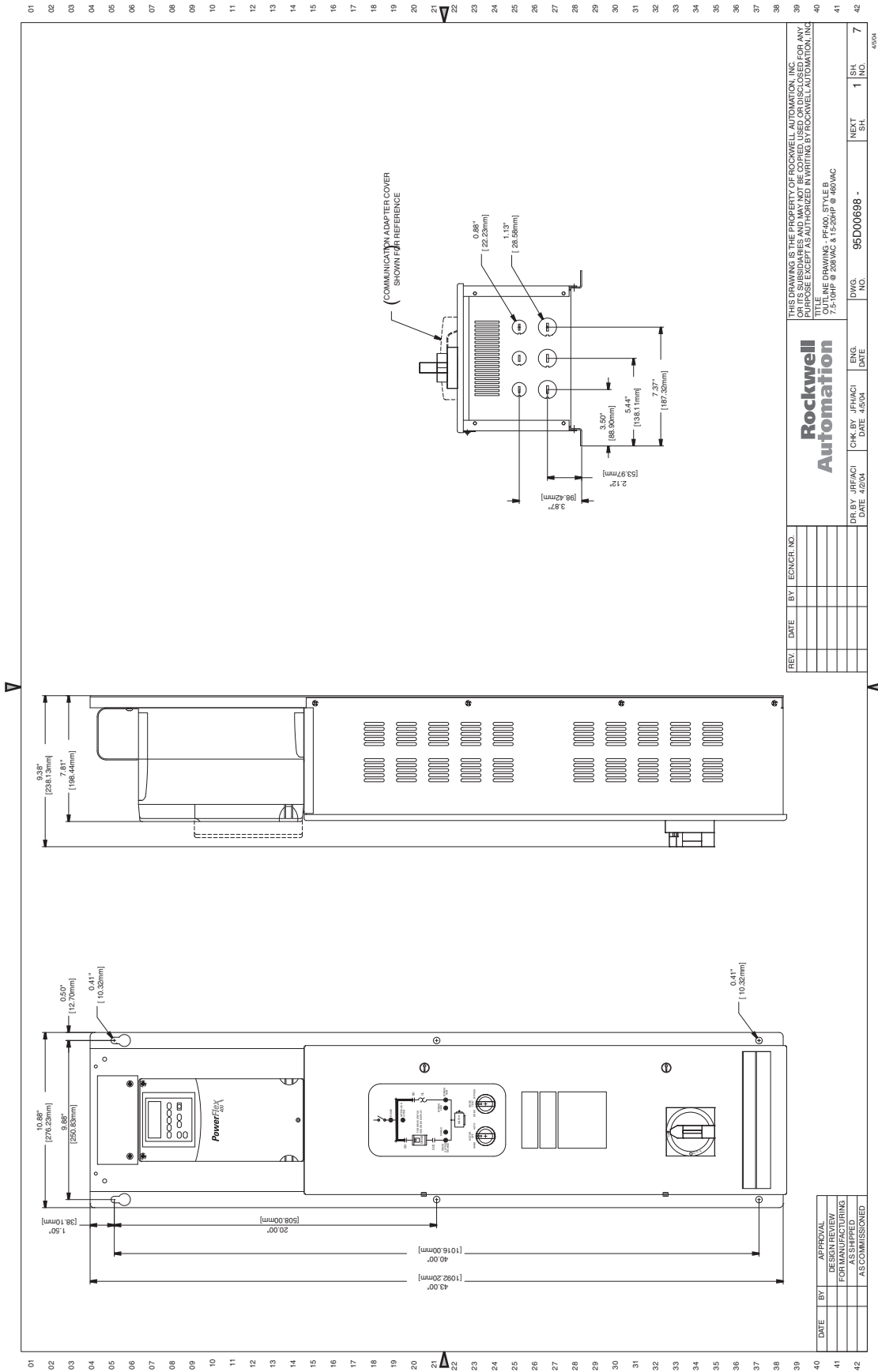

Figure 127 - 7.5...10 Hp, 208V AC and 15...20 Hp, 460V AC Drives - NEMA/UL Type 1



REV.	DATE	BY	ECNCR. NO.	DR. BY	JH/ACI	DATE	4/2/14	CHK. BY	JH/ACI	DATE	4/2/14	ENG. DATE	4/2/14	DWG. NO.	95D00698	NEXT SH.	1	SH. NO.	7

THIS DRAWING IS THE PROPERTY OF ROCKWELL AUTOMATION, INC. IT IS TO BE USED FOR THE PURPOSES SPECIFIED ONLY. NO PARTS OR MATERIALS ARE TO BE REPRODUCED OR TRANSMITTED IN ANY FORM OR BY ANY MEANS, ELECTRONIC OR MECHANICAL, INCLUDING PHOTOCOPYING, RECORDING, OR BY ANY INFORMATION STORAGE AND RETRIEVAL SYSTEM, WITHOUT THE WRITTEN PERMISSION OF ROCKWELL AUTOMATION, INC.

TITLE: ME DRAWING - PF40P, STYLE B
 7.5-10HP @ 208VAC & 15-20HP @ 460VAC

Figure 128 - 15...20 Hp, 208V AC and 25...40 Hp, 460V AC Drives - NEMA/UL Type 1

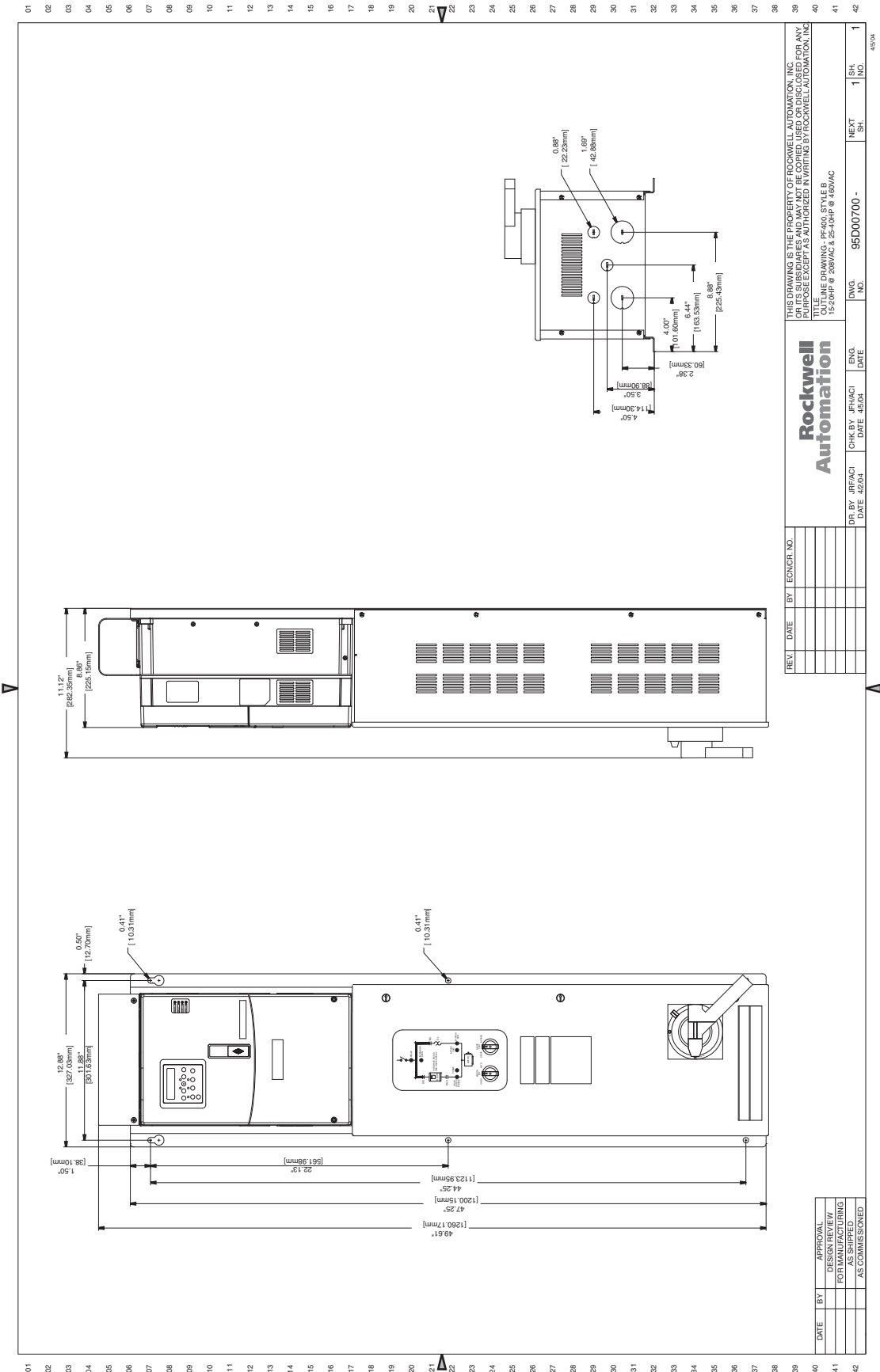
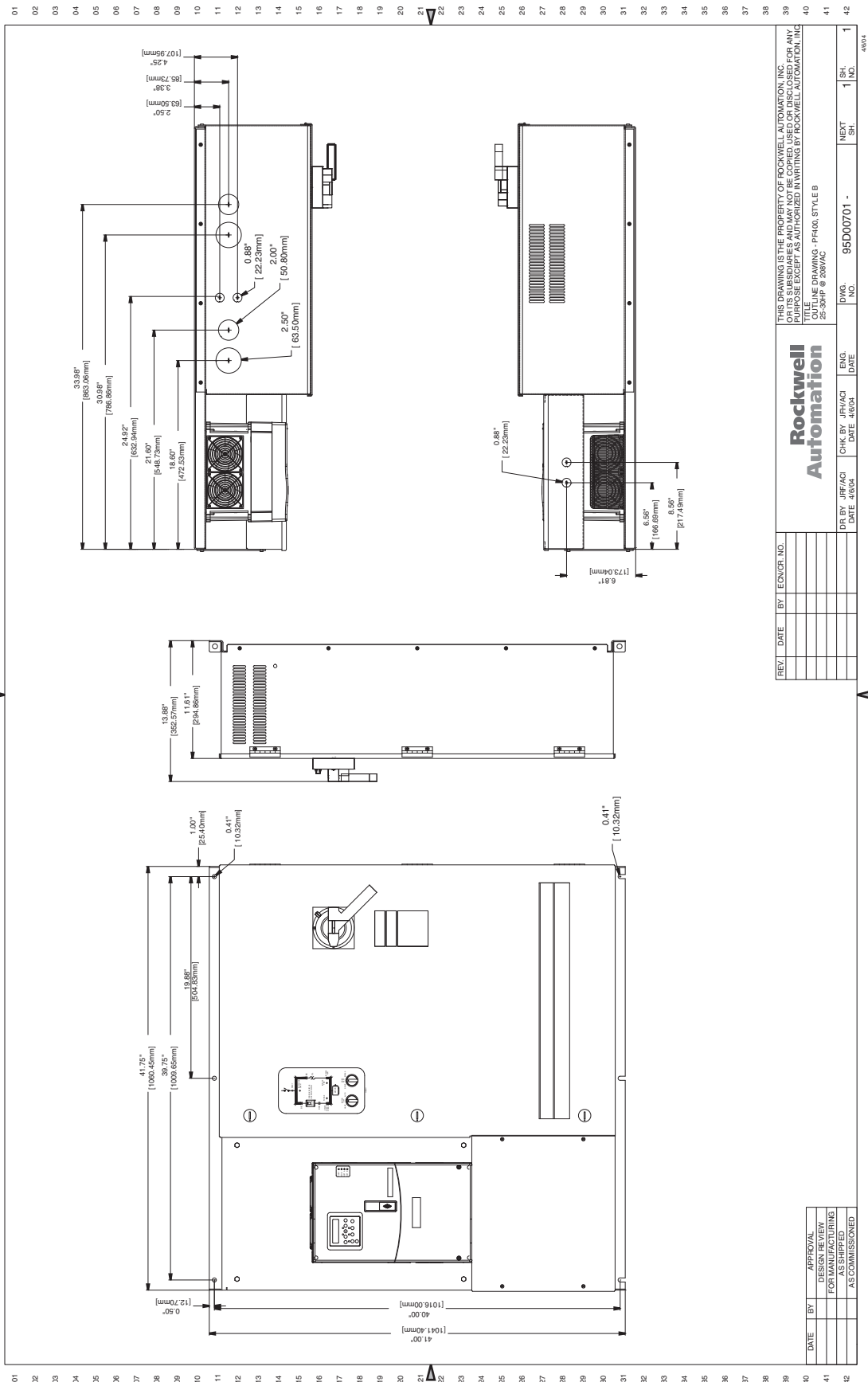

Figure 129 - 25...30 Hp, 208V AC Drives - NEMA/UL Type 1



REV.	DATE	BY	ECNOR. NO.	DR BY	JIR/ACI	DATE	4/2014	CHK BY	JIR/ACI	DATE	4/2014	ENG		DWG. NO.	95D00701 -	1	1	1	1
THIS DRAWING IS THE PROPERTY OF ROCKWELL AUTOMATION, INC. FOR ANY PURPOSE EXCEPT AS AUTHORIZED IN WRITING BY ROCKWELL AUTOMATION, INC.																			
TITLE: THE DRAWING - PH400, STYLE B 25-30HP @ 208VAC																			
Rockwell Automation																			
DATE	BY	APPROVAL	DESIGN REVIEW	FOR MANUFACTURING	AS COMMISSIONED														

Figure 130 - 40 Hp, 208V AC and 50...100 Hp, 460V AC Drives - NEMA/UL Type 1

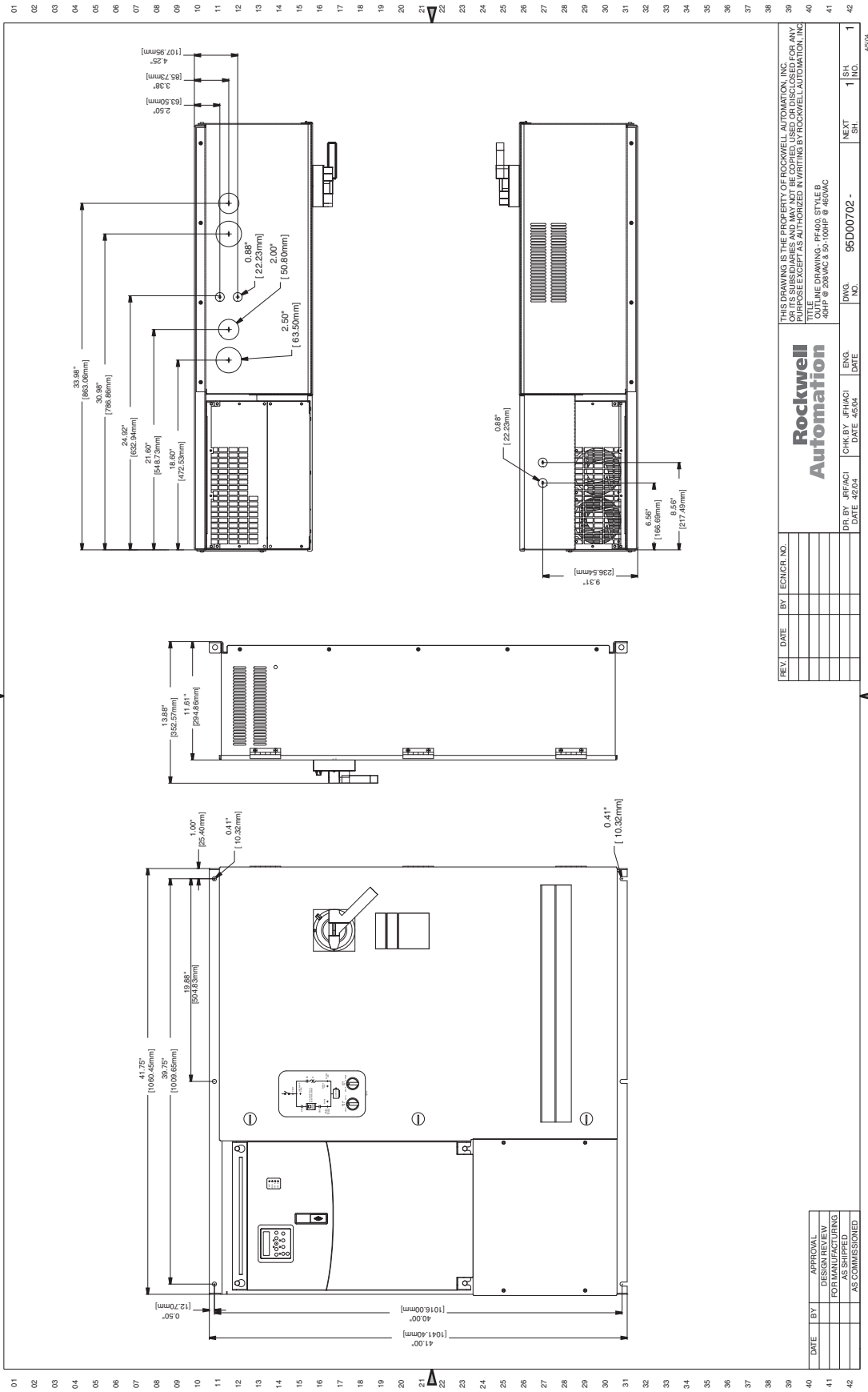
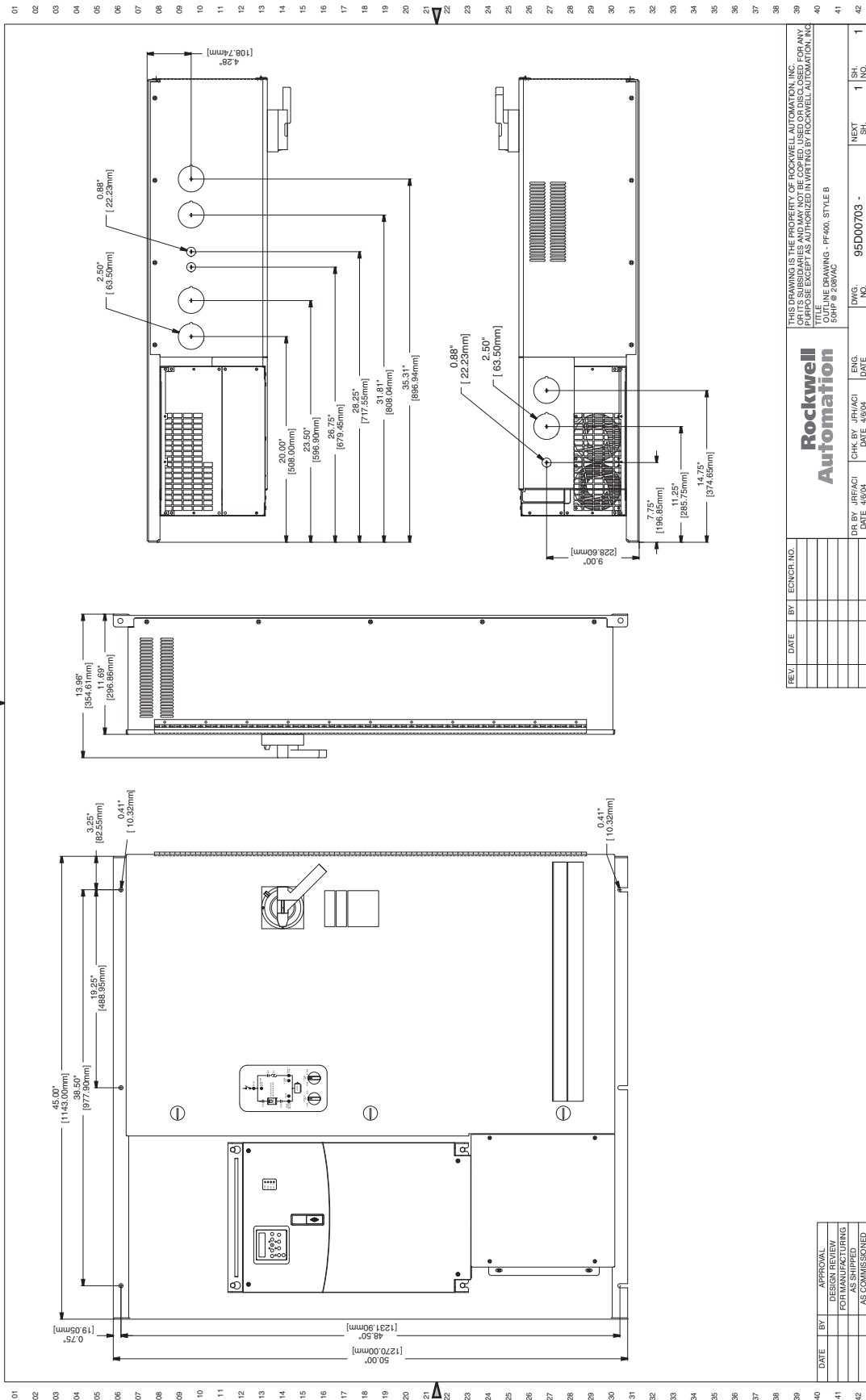

Figure 131 - 50 Hp, 208V AC Drives - NEMA/UL Type 1



REV	DATE	BY	ECNCR NO	DR BY	JRH/ACI	DATE	4/3/21	CHK BY	JRH/ACI	DATE	4/3/21	ENG	DATE	DWG. NO.	95D00703 -	NEXT SH.	1	SL. NO.	1

THIS DRAWING IS THE PROPERTY OF ROCKWELL AUTOMATION, INC. FOR ANY PURPOSE EXCEPT AS AUTHORIZED IN WRITING BY ROCKWELL AUTOMATION, INC.

TITLE: NEMA DRAWING - PF400, STYLE B
 50HP # Z08VAC

Rockwell Automation

Figure 132 - 125...150 Hp, 460V AC Drives - NEMA/UL Type 1

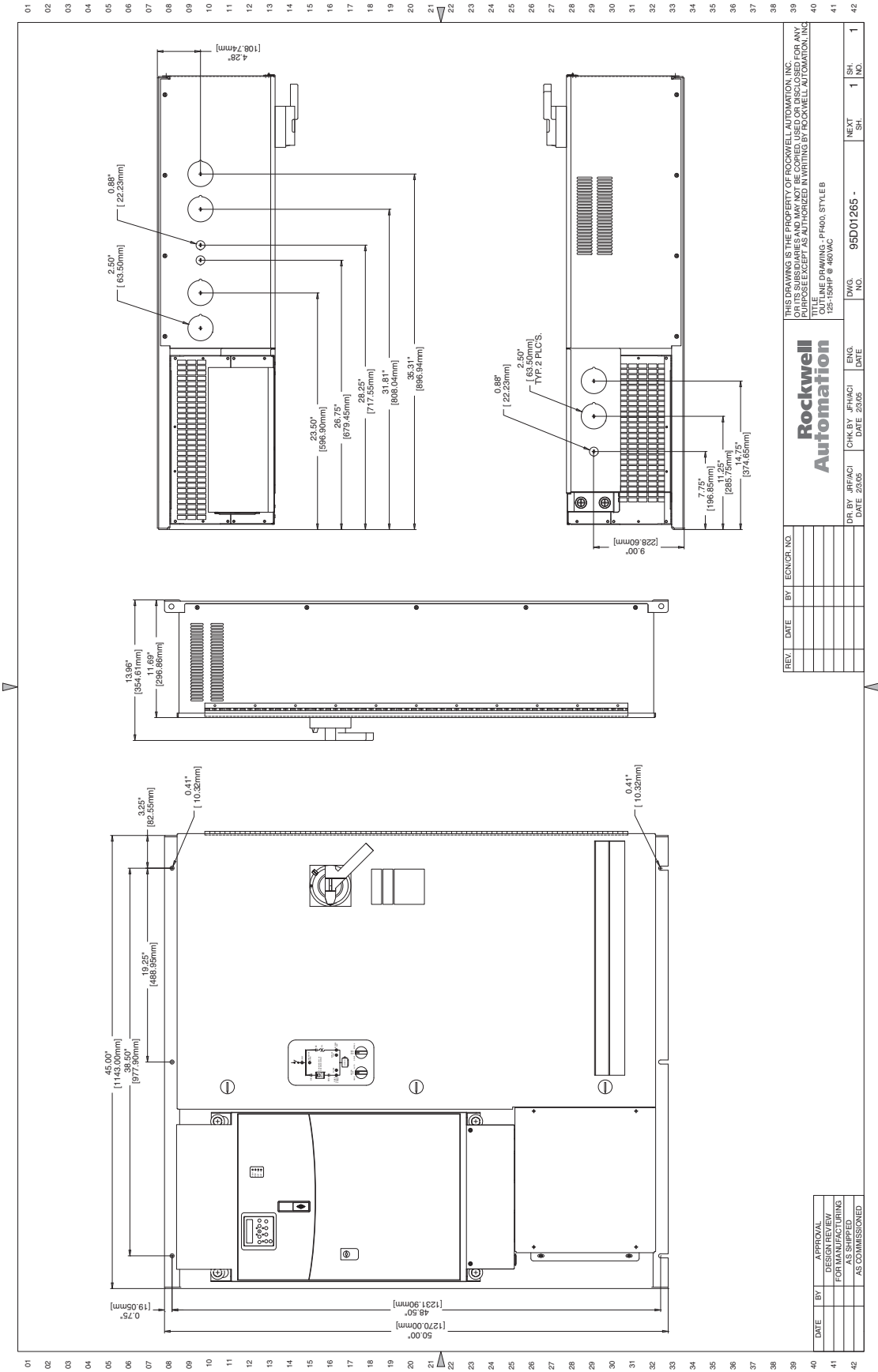

REV. DATE		BY	ECN/CR NO.	DR BY JRF/ACI		CHK BY JRF/ACI	ENG. DATE 2/2/05	DATE 2/2/05	NO.	DWG. NO.	95D01265 -	1	SH. NO.	1	SH. NO.	1
<p>THIS DRAWING IS THE PROPERTY OF ROCKWELL AUTOMATION, INC. ANY REPRODUCTION OR TRANSMISSION OF THIS DRAWING WITHOUT THE WRITTEN PERMISSION OF ROCKWELL AUTOMATION, INC. IS PROHIBITED.</p> <p>THIS DRAWING IS THE PROPERTY OF ROCKWELL AUTOMATION, INC. ANY REPRODUCTION OR TRANSMISSION OF THIS DRAWING WITHOUT THE WRITTEN PERMISSION OF ROCKWELL AUTOMATION, INC. IS PROHIBITED.</p> <p>THIS DRAWING IS THE PROPERTY OF ROCKWELL AUTOMATION, INC. ANY REPRODUCTION OR TRANSMISSION OF THIS DRAWING WITHOUT THE WRITTEN PERMISSION OF ROCKWELL AUTOMATION, INC. IS PROHIBITED.</p> <p>THIS DRAWING IS THE PROPERTY OF ROCKWELL AUTOMATION, INC. ANY REPRODUCTION OR TRANSMISSION OF THIS DRAWING WITHOUT THE WRITTEN PERMISSION OF ROCKWELL AUTOMATION, INC. IS PROHIBITED.</p>																
DATE	BY	APPROVAL	DESIGN REVIEW	FOR MANUFACTURING	AS SHIPPED	AS COMMISSIONED										

Figure 133 - 200...250 Hp, 460V AC Drives - NEMA/UL Type 1

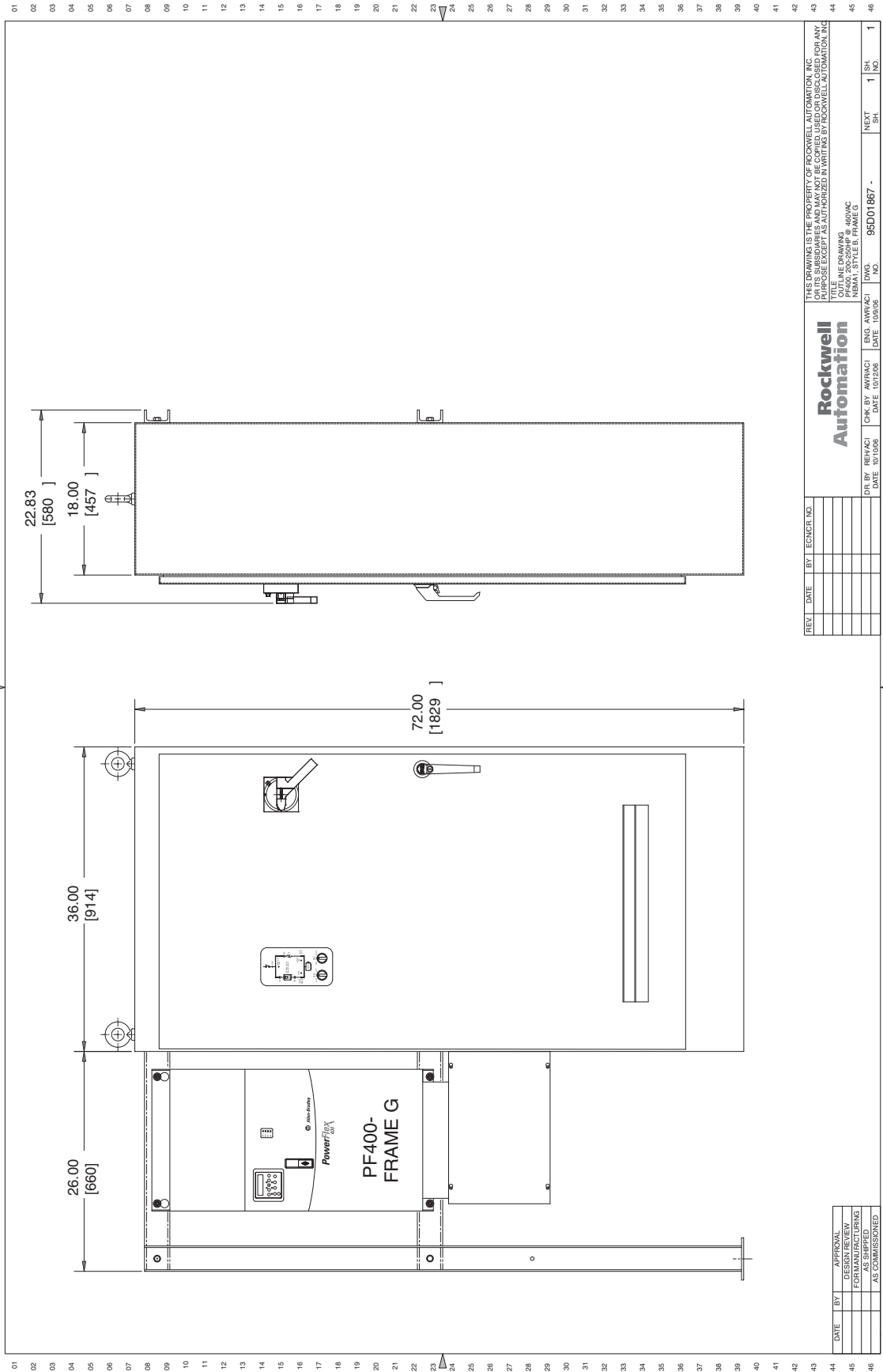

Figure 134 - 300...350 Hp, 460V AC Drives - NEMA/UL Type 1

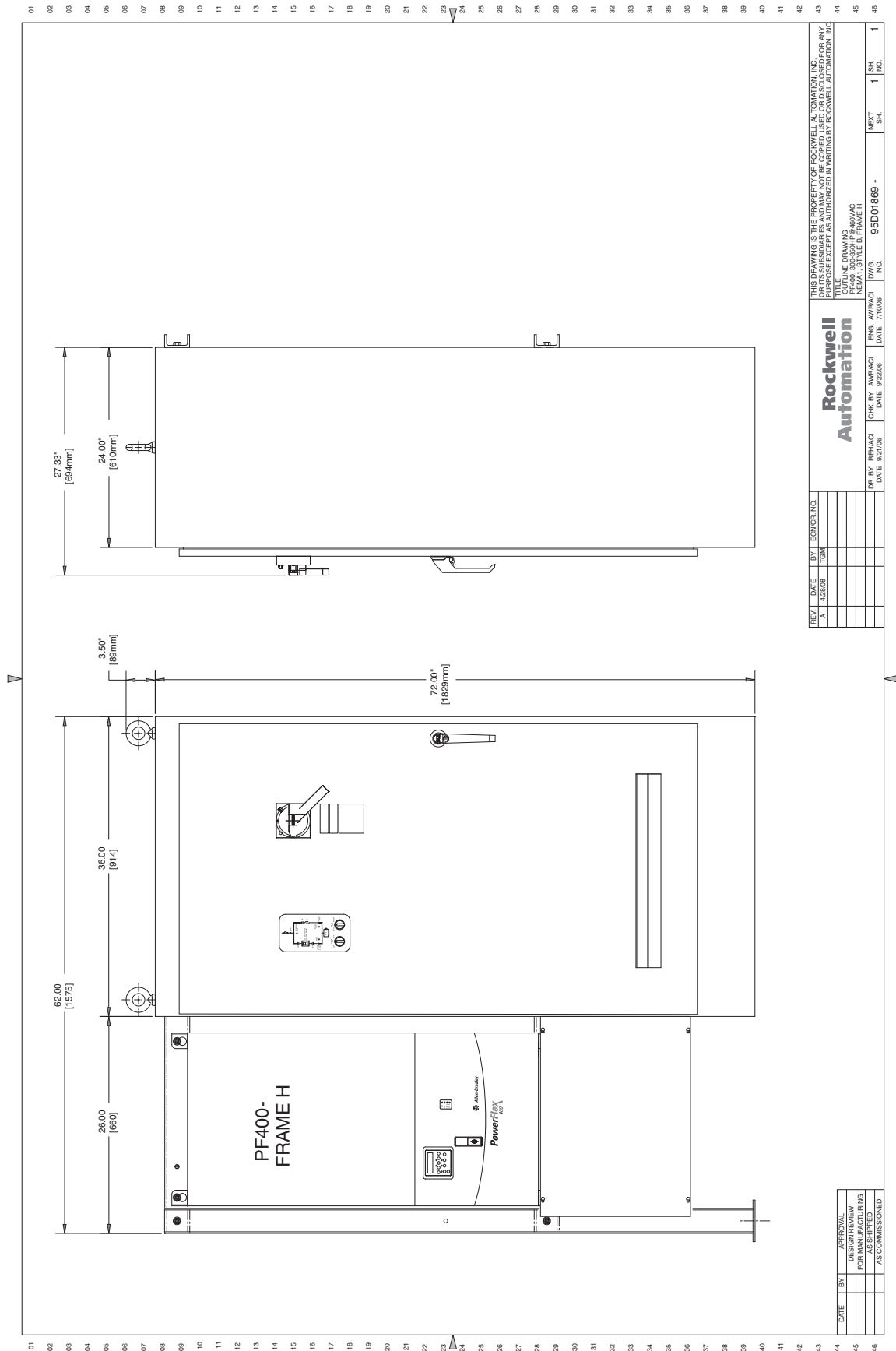

Figure 135 - 3.0...5.0 Hp, 208V AC and 3.0...10 Hp, 460V AC Drives with Line Reactor - NEMA/UL Type 1

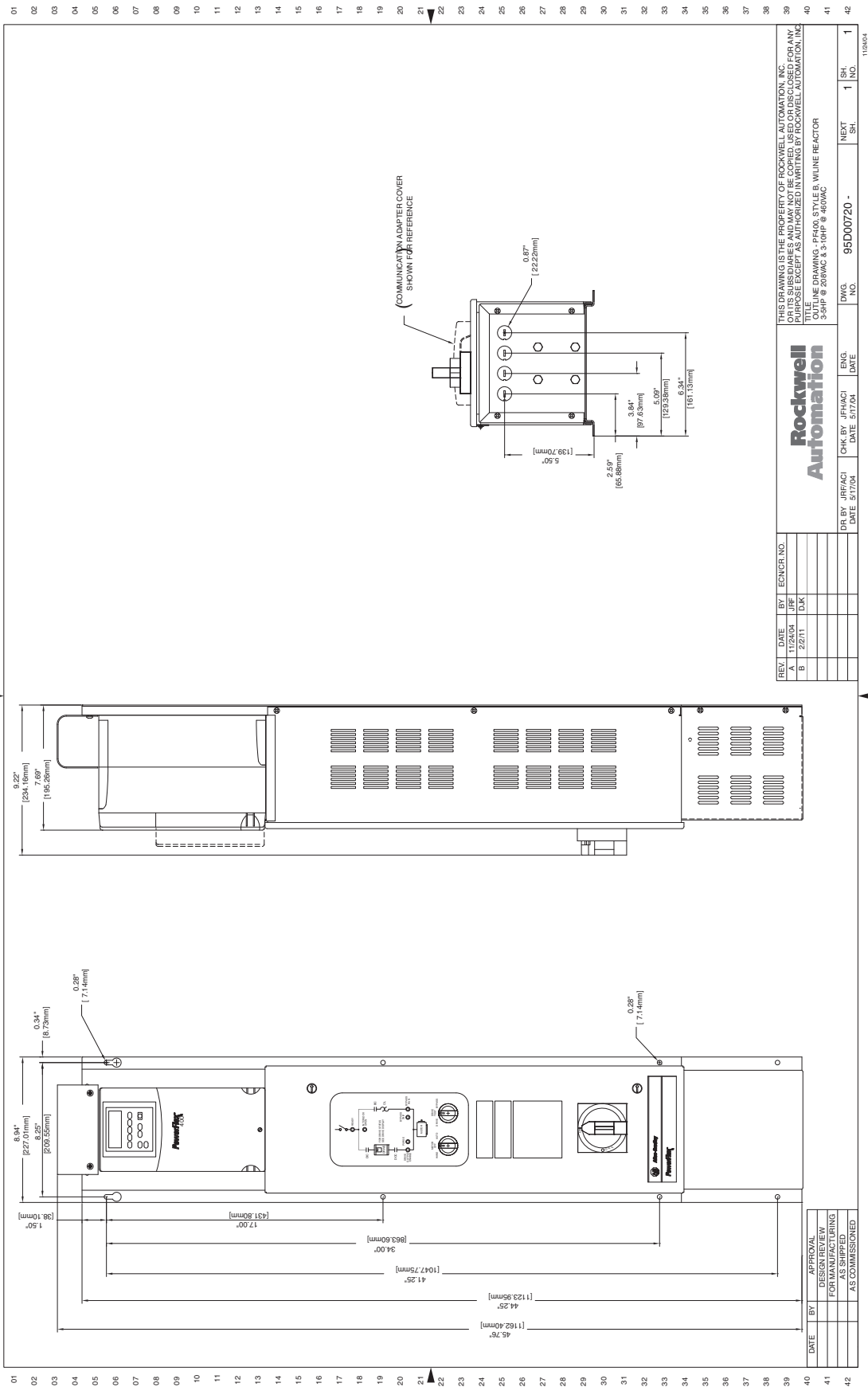

Figure 136 - 7.5...10 Hp, 208V AC and 15...20 Hp, 460V AC Drives with Line Reactor - NEMA/UL Type 1

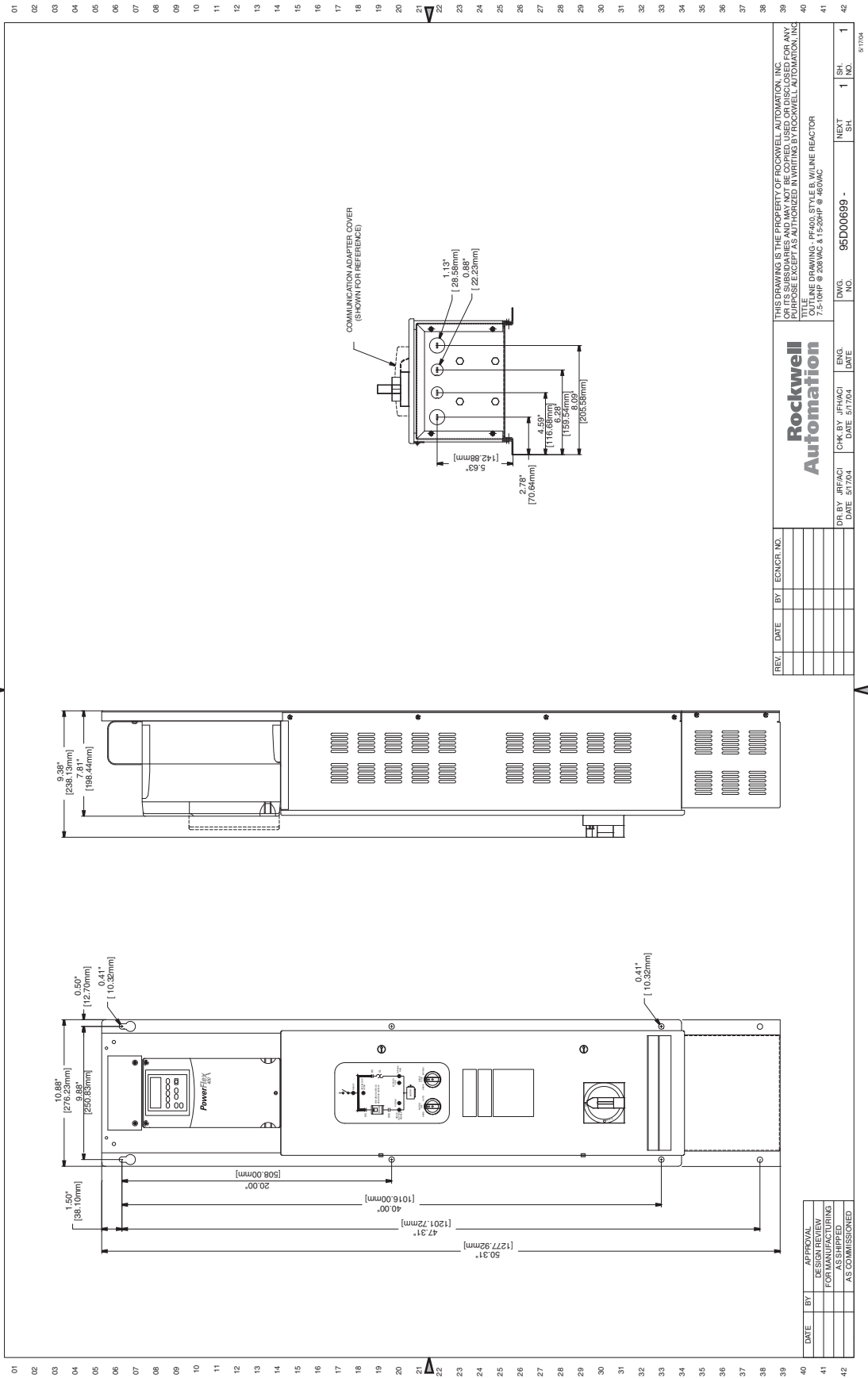

Figure 137 - 15...20 Hp, 208V AC and 25...40 Hp, 460V AC Drives with Line Reactor - NEMA/UL Type 1

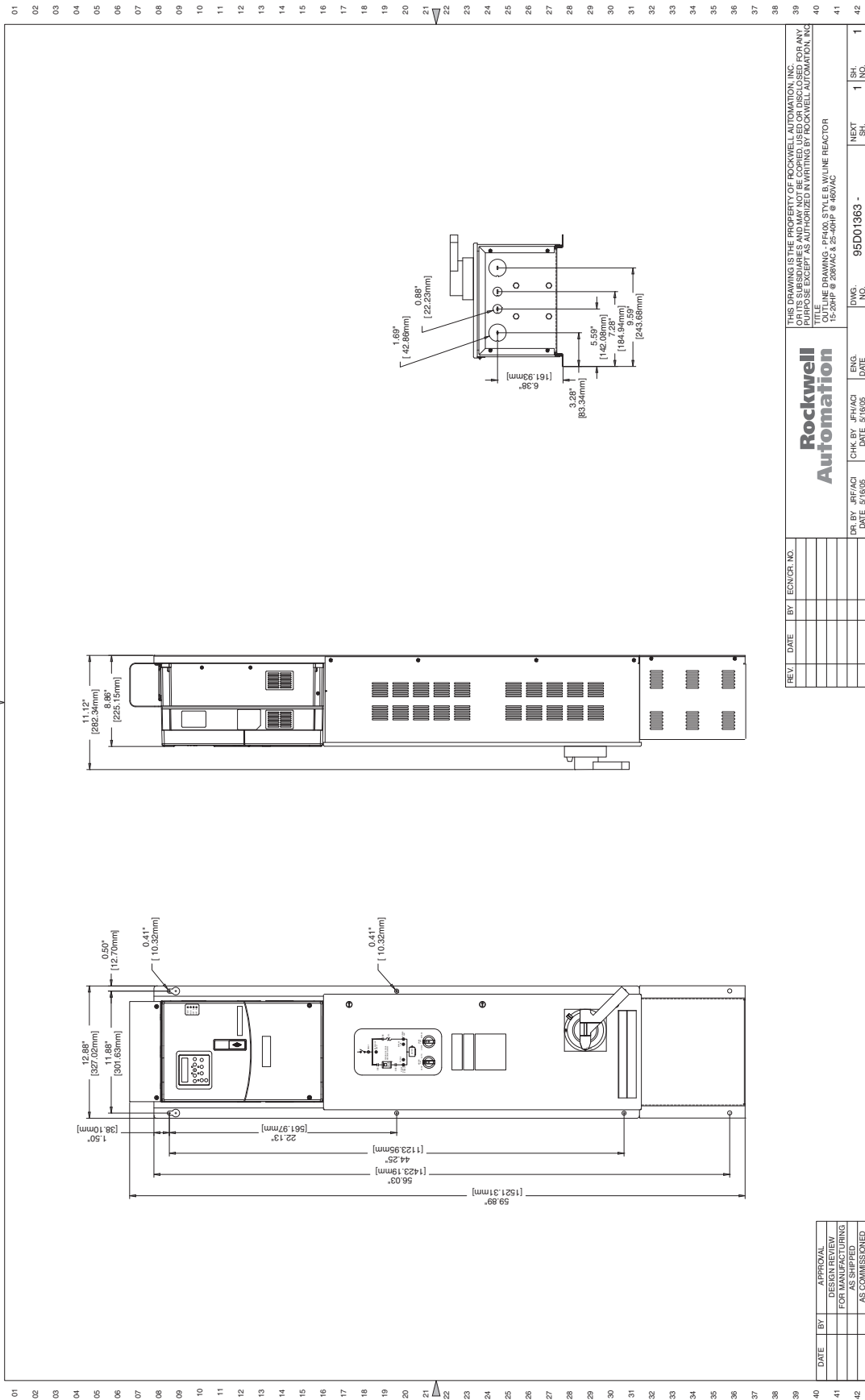

Figure 138 - 25...30 Hp, 208V AC Drives with Line Reactor - NEMA/UL Type 1

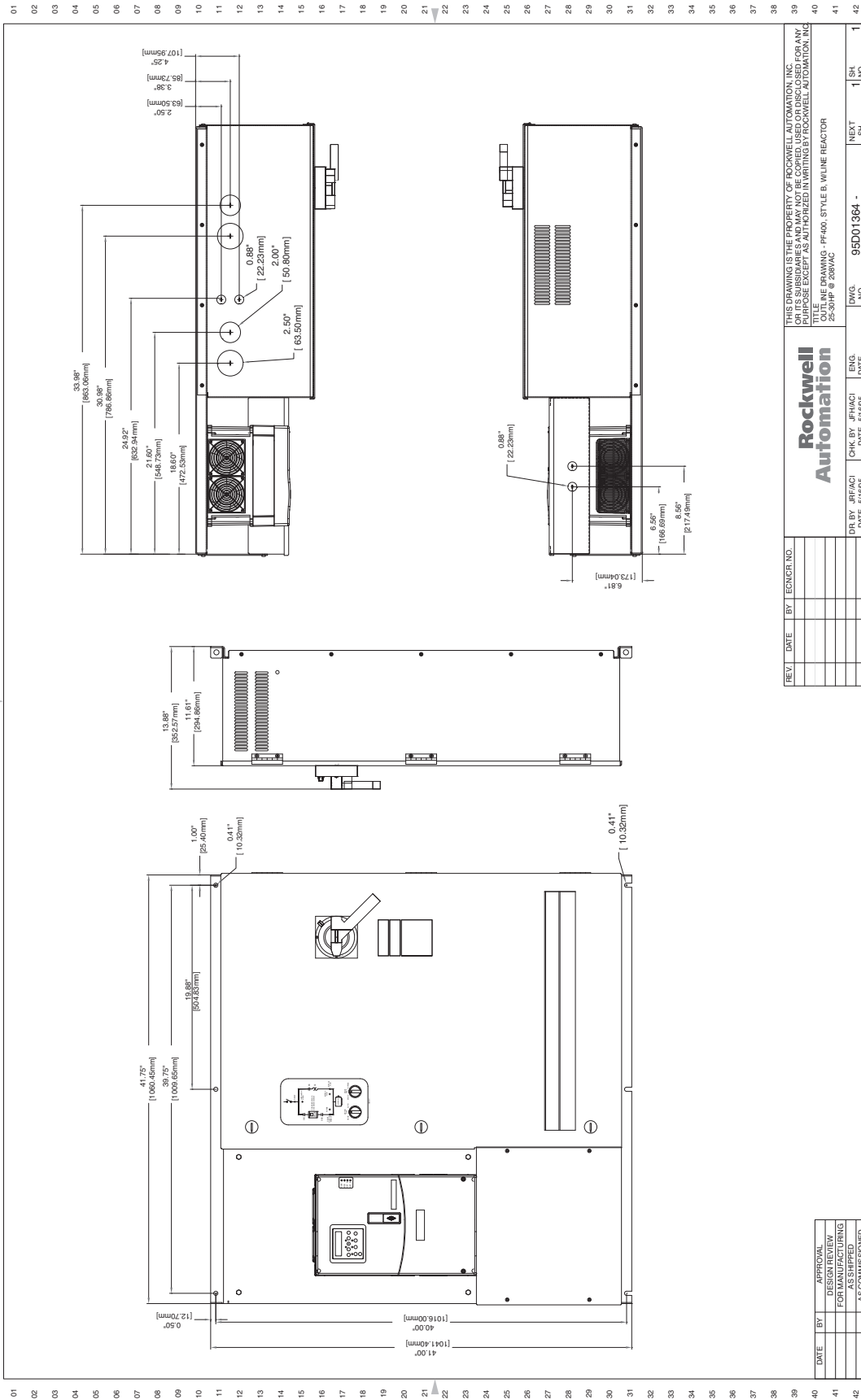

Figure 139 - 50...60 Hp, 460V AC Drives with Line Reactor - NEMAA/UL Type 1

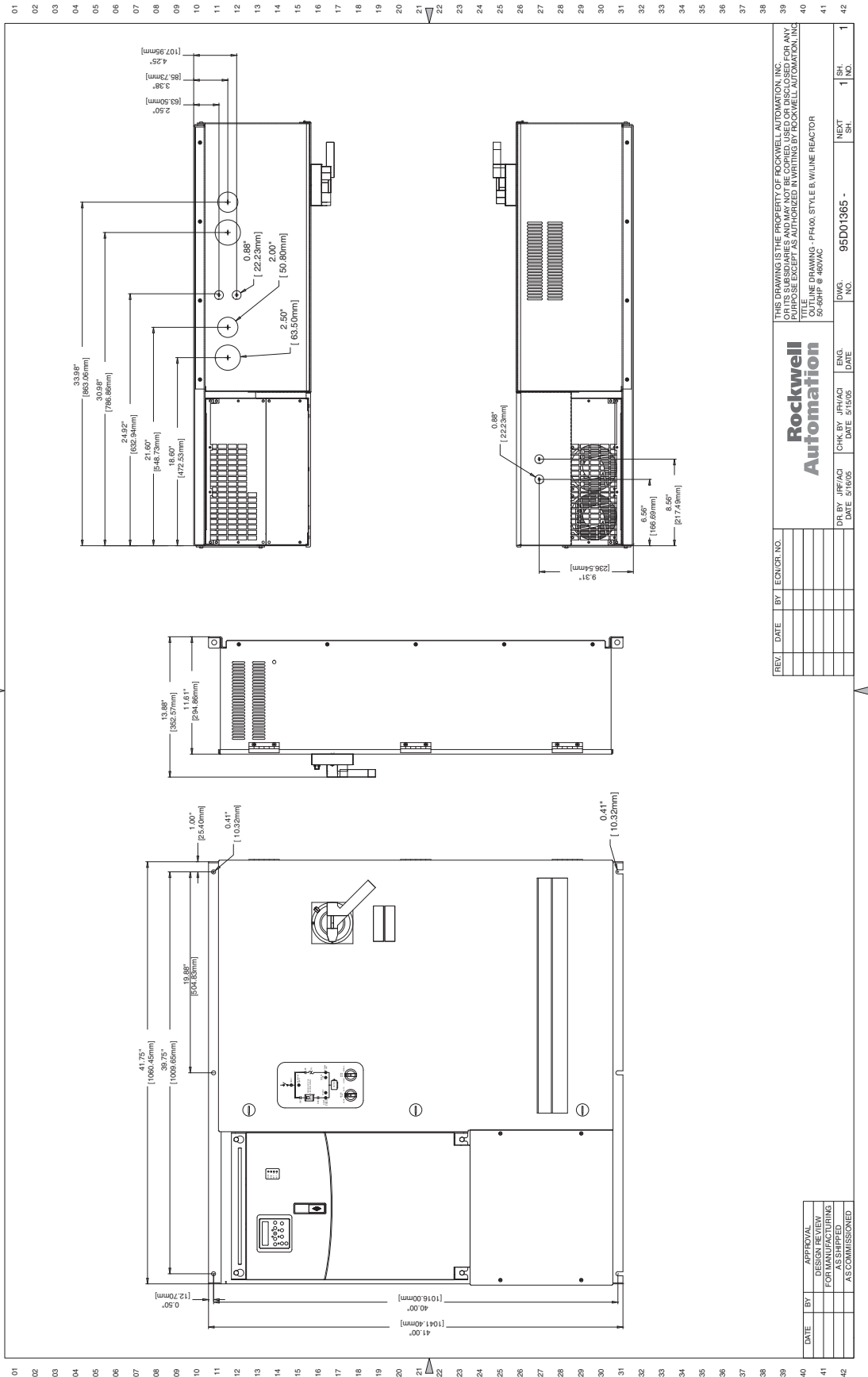

Figure 140 - 40...50 Hp, 208V AC and 75...100 Hp, 460V AC Drives with Line Reactor - NEMA/UL Type 1

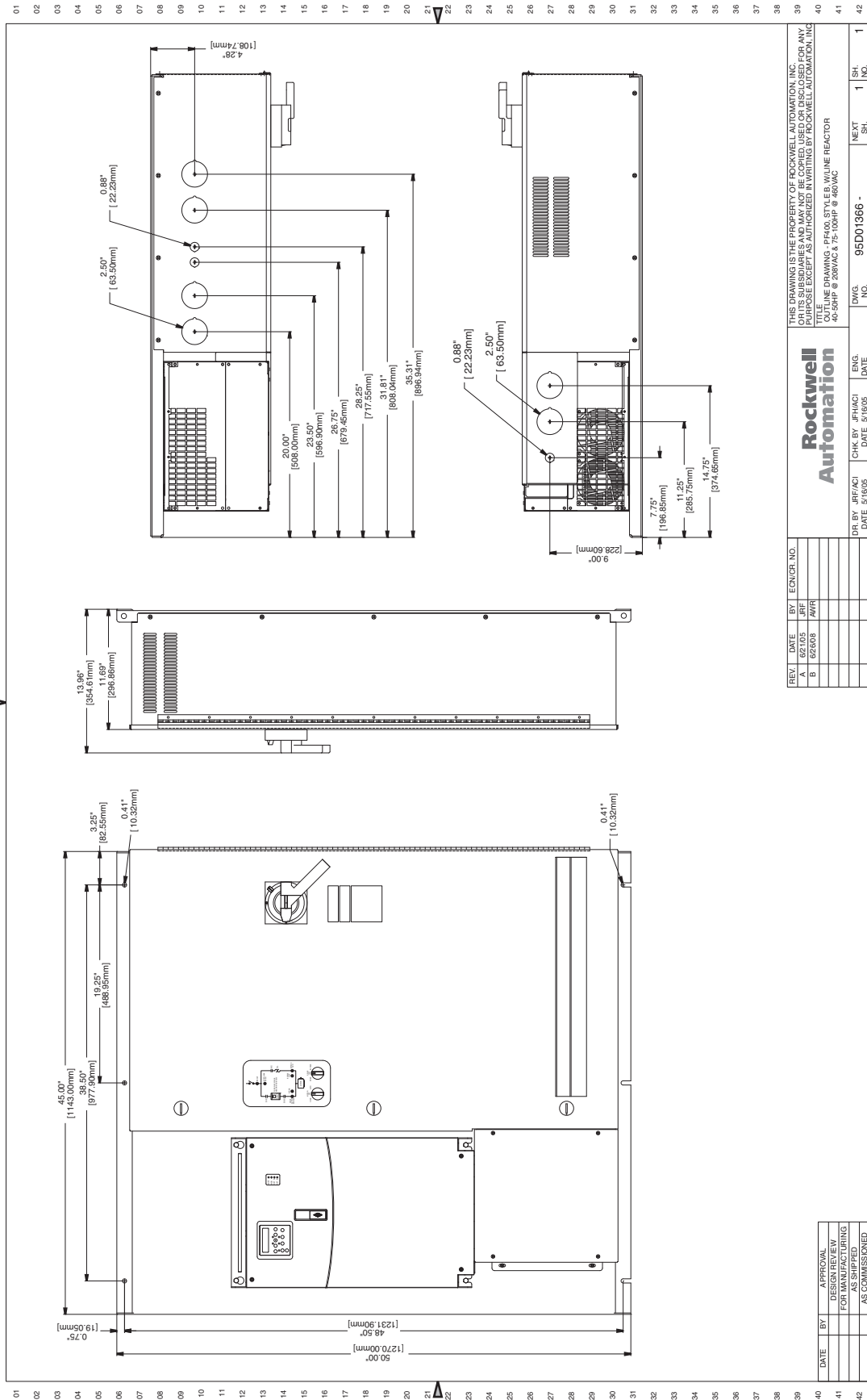

Figure 141 - 3.0...50 Hp, 208V AC and 3.0...150 Hp, 460V AC Drives - NEMA/UL Type 12

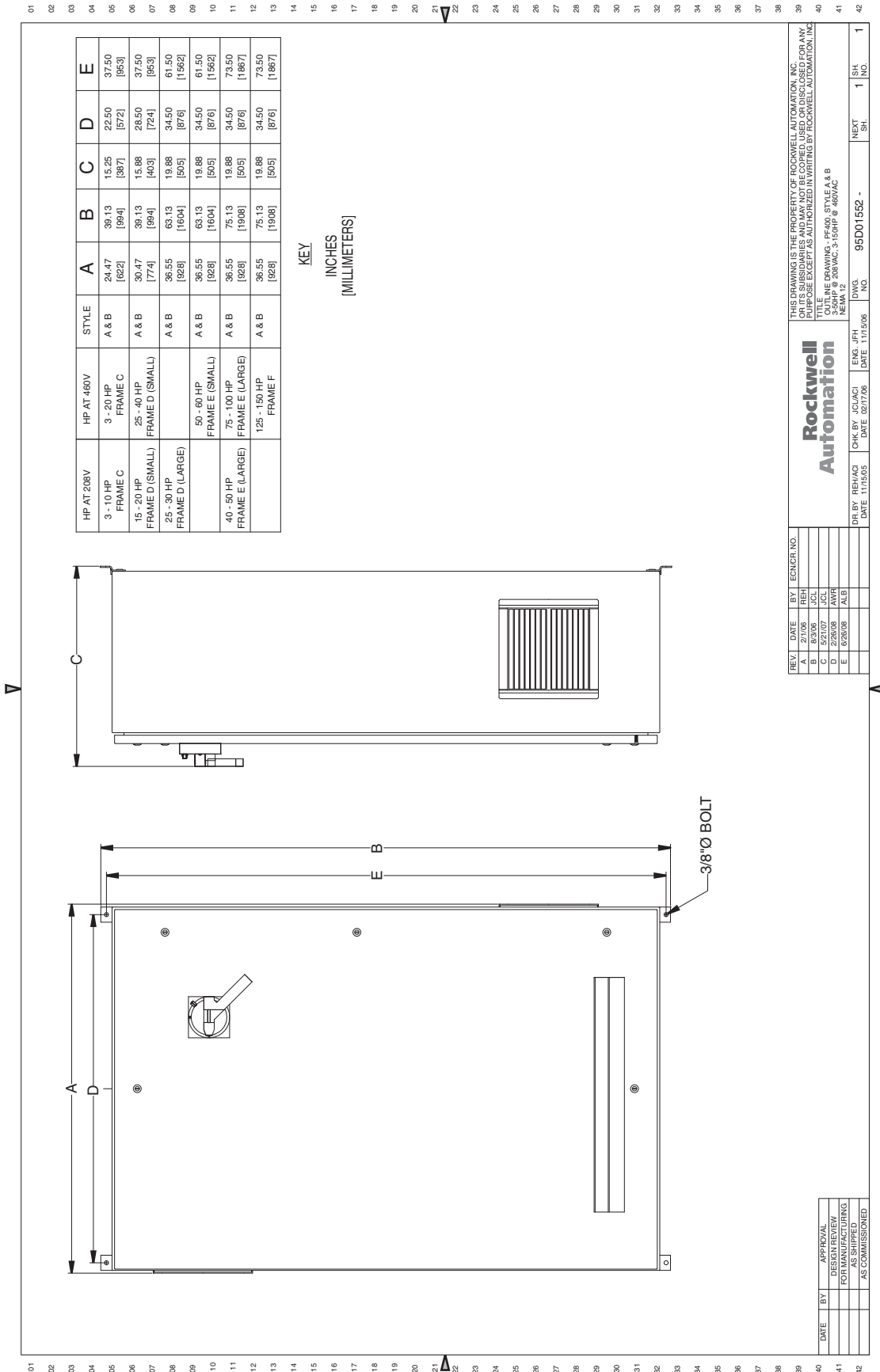
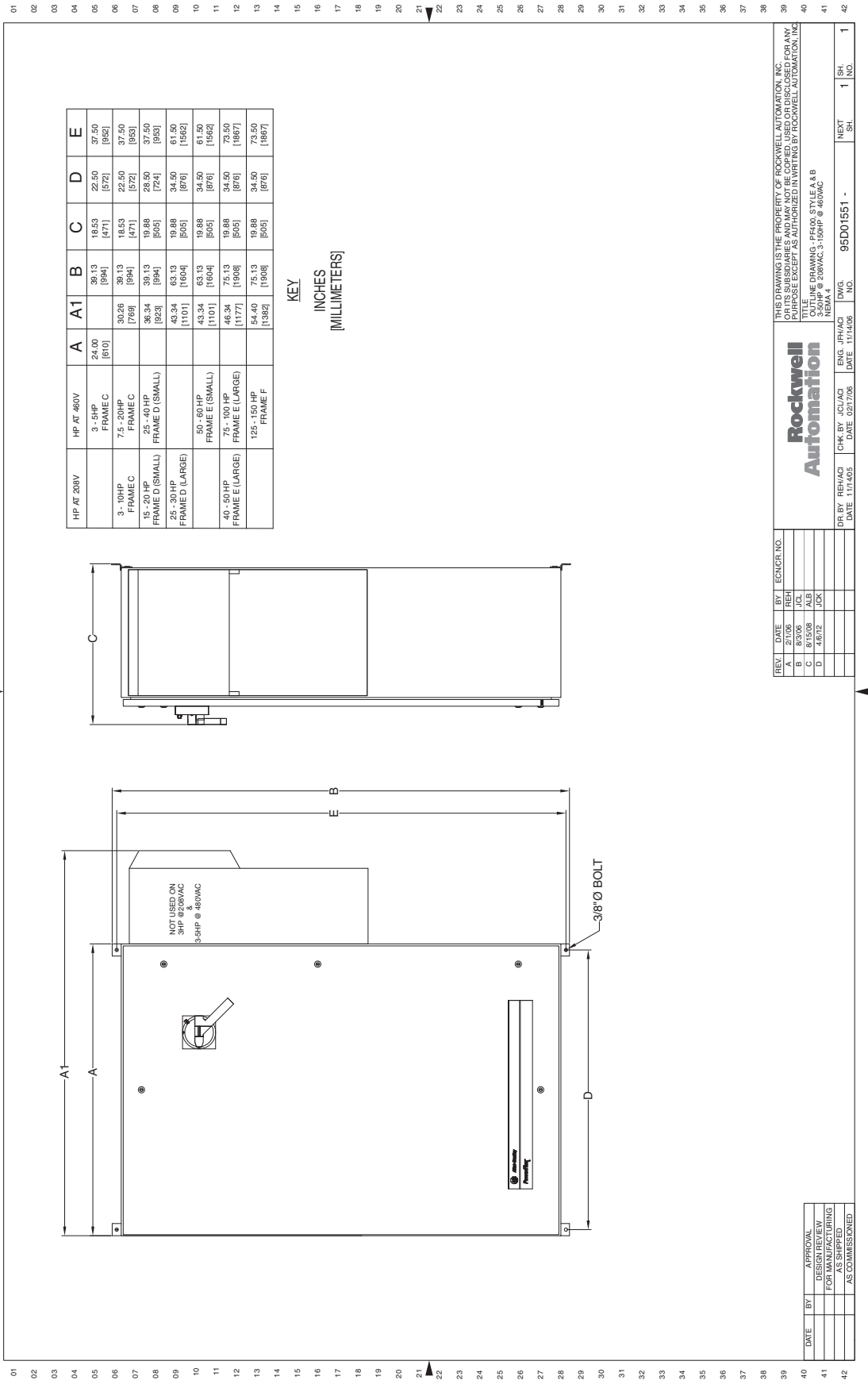

Figure 142 - 3.0...50 Hp, 208V AC and 3.0...150 Hp, 460V AC Drives - NEMA/UL Type 4



REV	DATE	BY	ECNCR. NO.
A	2/1/06	REH	
B	8/2/06	JCL	
C	4/6/12	JCL	
D	4/6/12	JCL	

THIS DRAWING IS THE PROPERTY OF ROCKWELL AUTOMATION, INC. OR ITS SUBSIDIARIES AND MAY NOT BE COPIED OR REPRODUCED FOR ANY PURPOSES WITHOUT THE WRITTEN PERMISSION OF ROCKWELL AUTOMATION, INC.

Rockwell Automation

DR BY: REH/ACI DATE: 11/14/05
 CHK BY: JCL/ACI DATE: 02/17/06
 ENG: JPH/ACI DATE: 11/14/06

DWG. NO. 95D01551 -
 NEXT SH. 1
 NO. 1

DATE	BY	APPROVAL
		DESIGN REVIEW
		FOR MANUFACTURING
		AS SHIPPED
		AS COMMISSIONED

Figure 143 - 3.0...50 Hp, 208V AC and 3.0...150 Hp, 460V AC Drives - NEMA/UL Type 3R

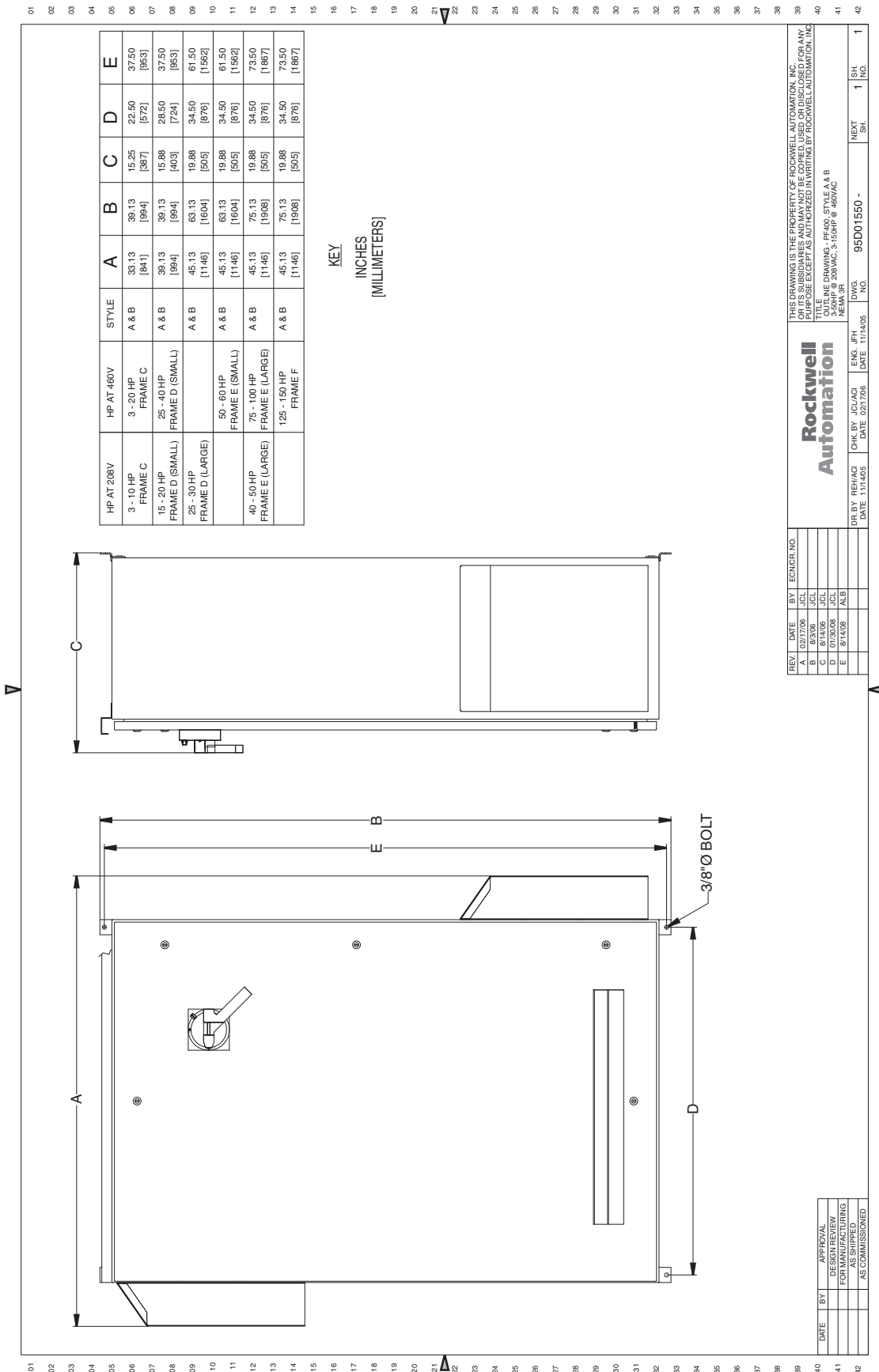

Mechanical Installation

This chapter provides information on mounting a PowerFlex® Drive Package for Fan and Pump Applications.

Topic	Page
Mounting Considerations	177
Lifting and Mounting the Drive	180
Watts Loss	181
Weights	182



ATTENTION: The following information is merely a guide for proper installation. The Allen-Bradley® Company cannot assume responsibility for the compliance or the noncompliance to any code, national, local or otherwise for the proper installation of this drive or associated equipment. A hazard of personal injury and/or equipment damage exists if codes are ignored during installation.

Mounting Considerations

Environment

Before deciding on an installation site, verify that the PowerFlex Drive Packages can be kept clean, cool, and dry. The drives should be kept away from oil, coolants, or other airborne contaminants.

Maximum Surrounding Air Temperature

PowerFlex Drive Packages for Fan and Pump Applications are designed to operate at 0...40 °C (32...104 °F) surrounding air temperature.

Minimum Mounting Clearances

Be sure that there is adequate clearance for air circulation around the drive. For best air movement, do not mount drives directly above each other. No devices are to be mounted behind the drive. This area must be kept clear of all control and power wiring.

Figure 144 - NEMA/UL Type 1 Minimum Mounting Clearances

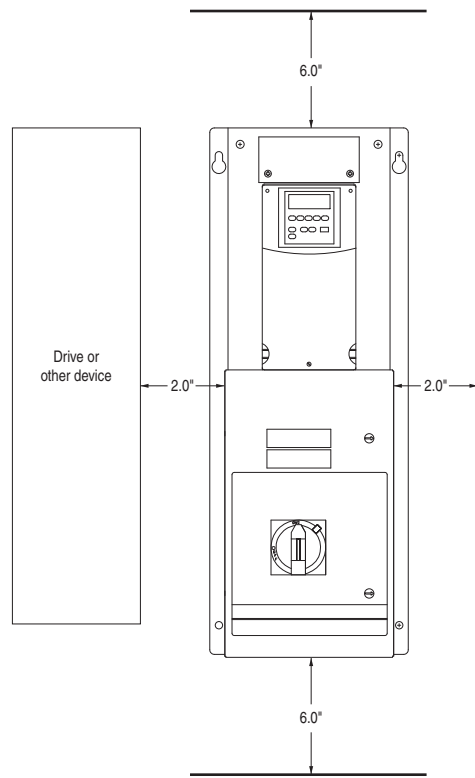

Figure 145 - NEMA/UL Type 12 Minimum Mounting Clearances

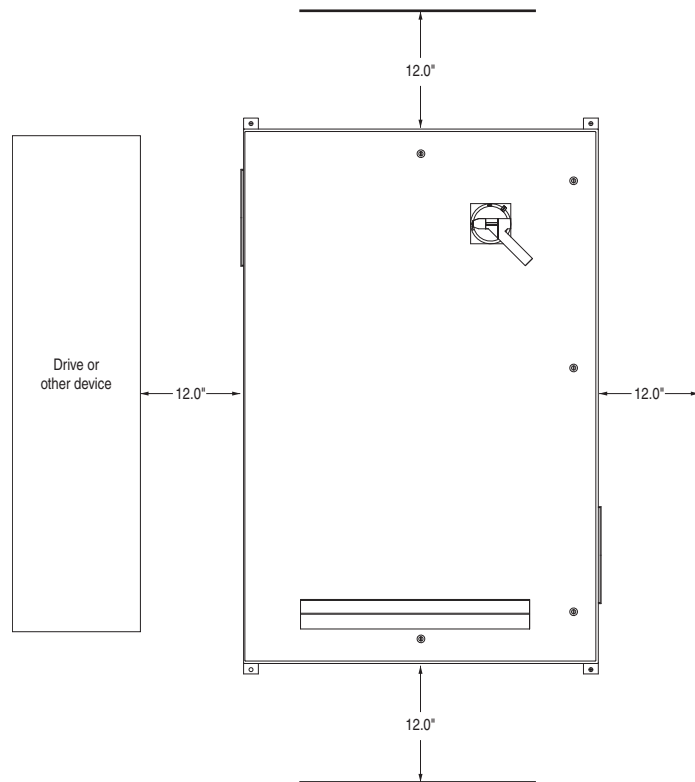

Figure 146 - NEMA/UL Type 4 Minimum Mounting Clearances

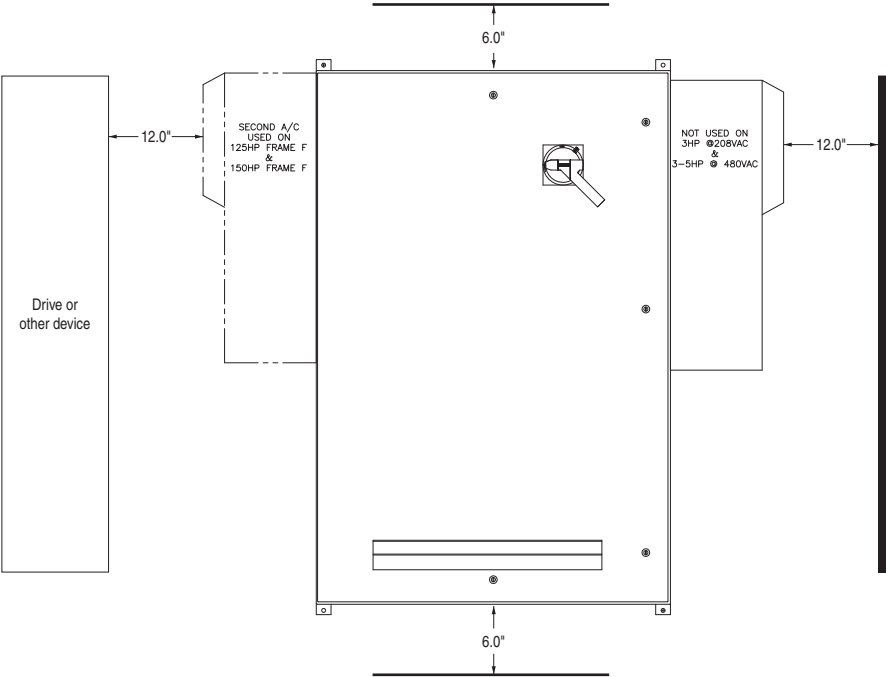
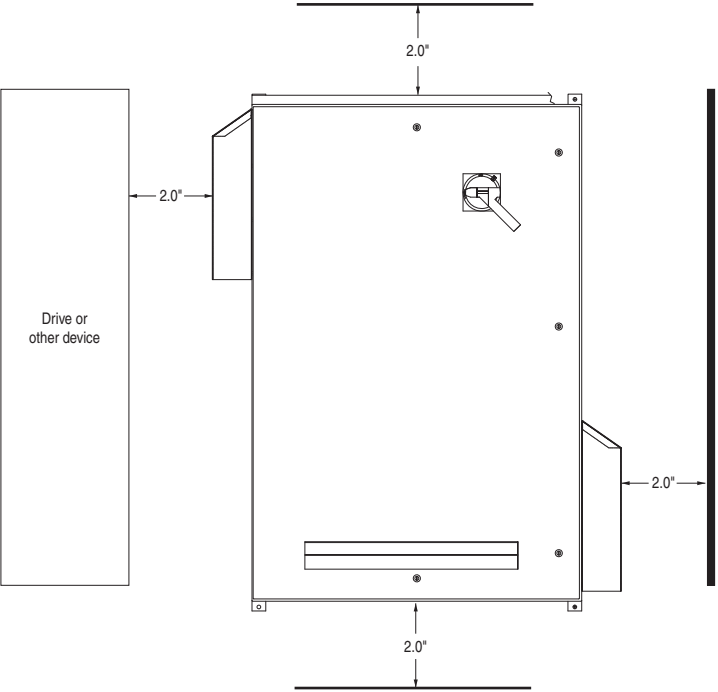

Figure 147 - NEMA/UL Type 3R Minimum Mounting Clearances



Lifting and Mounting the Drive

Care should be used to prevent damage due to dropping or jolting when moving the drive. A fork lift truck or similar means of lifting and transporting may be used. Sling in a manner that will equalize the load at the pickup points. Use a spreader bar if the angle of the sling is less than 45° relative to horizontal. Do not jolt while lifting.

Figure 148 - Lifting the Drive

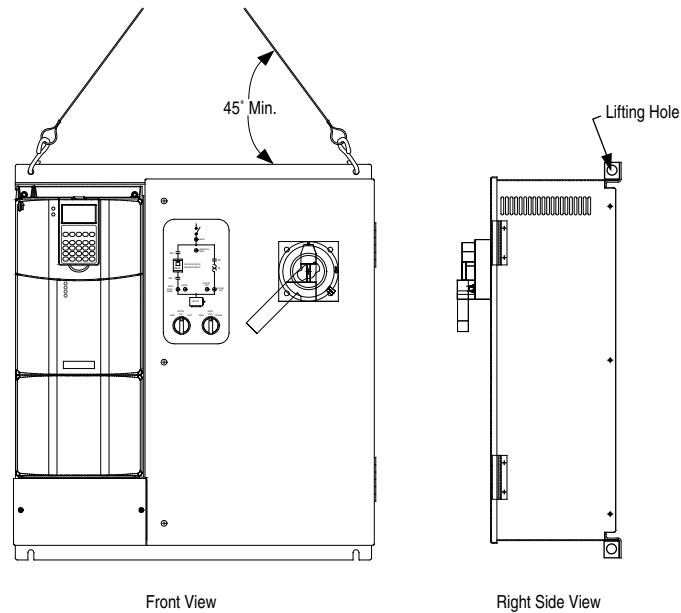

Use the following procedure to lift and mount the drive.

1. Attach a sling with safety hooks or clevis clamps to the two lifting holes. Verify that the angle of the sling is not less than 45° relative to horizontal.
2. Using an overhead or portable hoist, attach a free-fall chain to the chain secured to the drive. Take up any vertical slack in the chain.
3. Using the hoist, lift the drive from the horizontal shipping pallet.
4. Position the drive.
5. Attach the drive to a vertical surface using the mounting holes provided. Use washers under the bolt heads.

Watts Loss

The following table lists watt loss data for PowerFlex Drive Packages for Fan and Pump Applications running at full load, full speed, and a factory default PWM frequency of 4 kHz.

Table 11 - Watts Loss at Full Load/Speed, 4 kHz

Voltage	kW	Hp	Total Watts
208V AC	2.2	3.0	180
	3.7	5.0	220
	5.5	7.5	308
	7.5	10	375
	11	15	498
	15	20	660
	18.5	25	744
	22	30	788
	30	40	1065
	37	50	1210
460V AC	2.2	3.0	135
	3.7	5.0	195
	5.5	7.5	209
	7.5	10	253
	11	15	336
	15	20	443
	18.5	25	499
	22	30	529
	30	40	713
	37	50	810
	45	60	1132
	55	75	1288
	75	100	1560
	90	125	1910
	110	150	2310
	132	200	3711
160	250	4208	
200	300	4916	
250	350	6167	

Weights

The following tables list weights for PowerFlex 400 Drive Packages for Fan and Pump Applications. Weights are approximate.

Table 12 - Main Input Disconnect Package (Style A/M)

Voltage	kW	Hp	Input Line Reactor	Weight kg (lbs)	
208V AC	2.2	3.0	No	13.2 (29)	
	3.7	5.0		13.2 (29)	
	5.5	7.5		13.2 (29)	
	7.5	10		13.2 (29)	
	11	15		Consult Factory	
	15	20		Consult Factory	
	18.5	25		42.2 (93)	
	22	30		42.2 (93)	
	30	40		68.0 (150)	
	37	50		Consult Factory	
	2.2	3.0		Yes	Consult Factory
	3.7	5.0			Consult Factory
	5.5	7.5			Consult Factory
	7.5	10			Consult Factory
460V AC	2.2	3.0	No	12.7 (28)	
	3.7	5.0		12.7 (28)	
	5.5	7.5		12.7 (28)	
	7.5	10		12.7 (28)	
	11	15		12.7 (28)	
	15	20		12.7 (28)	
	18.5	25		26.3 (58)	
	22	30		26.3 (58)	
	30	40		26.3 (58)	
	37	50		61.7 (136)	
	45	60		61.7 (136)	
	55	75		61.7 (136)	
	75	100		61.7 (136)	
	90	125		Consult Factory	
	110	150		Consult Factory	
	132	200		184.6 (407)	
	160	250		186.9 (412)	
	200	300		362.0 (798)	
	250	350		362.0 (798)	
	2.2	3.0		Yes	18.6 (41)
3.7	5.0	18.6 (41)			
5.5	7.5	18.6 (41)			
7.5	10	18.6 (41)			
11	15	25.9 (57)			
15	20	25.9 (57)			

Table 13 - 3 Contactor Full Feature Bypass with Disconnect Package (Style B/N)

Voltage	kW	Hp	Input Line Reactor	Weight kg (lbs)		
208V AC	2.2	3.0	No	18.6 (41)		
	3.7	5.0		18.6 (41)		
	5.5	7.5		Consult Factory		
	7.5	10		Consult Factory		
	11	15		39.9 (88)		
	15	20		39.9 (88)		
	18.5	25		93.0 (205)		
	22	30		93.0 (205)		
	30	40		Consult Factory		
	37	50		Consult Factory		
	2.2	3.0		Yes	Consult Factory	
	3.7	5.0			Consult Factory	
	5.5	7.5			Consult Factory	
	7.5	10			Consult Factory	
	460V AC	2.2		3.0	No	18.1 (40)
		3.7		5.0		18.1 (40)
		5.5		7.5		18.1 (40)
		7.5		10		18.1 (40)
11		15	24.5 (54)			
15		20	24.5 (54)			
18.5		25	34.9 (77)			
22		30	34.9 (77)			
30		40	34.9 (77)			
37		50	131.5 (290)			
45		60	131.5 (290)			
55		75	131.5 (290)			
75		100	131.5 (290)			
90		125	Consult Factory			
110		150	Consult Factory			
132		200	322.1 (710)			
160		250	324.3 (715)			
200		300	392.4 (865)			
250		350	408.7 (901)			
2.2		3.0	Yes	23.6 (52)		
3.7		5.0		23.6 (52)		
5.5		7.5		23.6 (52)		
7.5	10	23.6 (52)				
11	15	34.0 (75)				
15	20	34.0 (75)				

Notes:

Electrical Installation

This chapter provides information on electrical installation of a PowerFlex® Drive Package for Fan and Pump Applications.

Topic	Page
Power Wire Size Requirements	185
Power Terminal Block Specification	185
Control and Signal Wiring	186
Installing Input Power Wiring	186
Installing Output Power Wiring	187
Installing an Optional Transformer or Reactor	187

Power Wire Size Requirements

Wire size should be determined based on the size of the conduit openings, and applicable local, national, and international codes such as NEC/CEC.



ATTENTION: National codes and standards (NEC, VDE, BSI, and so on) and local codes outline provisions for safely installing electrical equipment. Installation must comply with specifications regarding wire types, conductor sizes, branch circuit protection, and disconnect devices. Failure to do so may result in personal injury and/or equipment damage.

Power Terminal Block Specification

Input power wiring should be sized according to applicable codes to handle the drive's continuous-rated input current. Output wiring should be sized according to applicable codes to handle the drive's continuous-rated output current. See [Table 14](#) for the range of power wire sizes that the terminals can accommodate.

Table 14 - Power Wire Sizes

Name	Package Style	Hp		Wire Size Range		Torque
		208V AC	480V AC	Minimum	Maximum	
Input Power L1 (R), L2 (S), L3 (T)	A & B	3...5	3...10	14 AWG	8 AWG	12
		7.5...10	15...25	14 AWG	4 AWG	35
		15...20	30...50	14 AWG	2 AWG	35
		25...40	60...100	6 AWG	250 MCM	275
		50	125...200	(2) 1/0	350 MCM	275
		—	250...300	(2) 2/0	350 MCM	275
		—	350	(3) 3/0	350 MCM	275

Name	Package Style	Hp		Wire Size Range		Torque
		208V AC	480V AC	Minimum	Maximum	
Output Power T1(U), T2(V), T3(W)	A	3...10	3...20	16 AWG	8 AWG	26
		15...30	25...40	8 AWG	2 AWG	45
		—	50...60	12 AWG	2 AWG	49.5
		40...50	75...150	1/0 AWG	4/0 AWG	173
		—	200...250	(1)	(1)	260
		—	300...350	(1)	(1)	354
	B	3...7.5	3...7.5	22 AWG	8 AWG	13
		10...20	10...30	14 AWG	4 AWG	19
		25...30	40...75	12 AWG	1/0 AWG	40
		—	100...150	6 AWG	350 MCM	275
		40...50	200...300	(2) 4 AWG	350 MCM	500
		—	350	(2) 250 MCM	750 MCM	375

(1) Threaded studs provided for wire lugs.

Control and Signal Wiring

The terminal block on the Main Control board provides terminals for 24 V DC power for the eight remote control inputs and outputs. The terminal block in the options cabinet provides terminals for 115 V AC power for the remote control inputs and outputs. The options cabinet terminal block is factory-wired to the terminal block on the Main Control board.

Installing Input Power Wiring



ATTENTION: Protect the contents of the options cabinet from metal chips and other debris while drilling the conduit openings. Failure to observe this precaution could result in damage to, or destruction of, the equipment.



ATTENTION: Do not route signal and control wiring with power wiring in the same conduit. This can cause interference with drive operation. Failure to observe this precaution could result in damage to, or destruction of, the equipment.

To connect AC input power to the drive:

- ❑ Step 1. Wire the AC input power leads by routing them according to drive type. Power wiring sizes are listed in [Table 14](#) on page [185](#).
- ❑ Step 2. Connect the three-phase AC input power leads (three-wire V AC) to the appropriate terminals. Connect the AC input power leads to terminals R/L1, S/L2, T/L3 on the power terminal block.
- ❑ Step 3. Tighten the AC input power terminals to the proper torque according to drive type as shown in [Table 14](#) on page [185](#).

Installing Output Power Wiring



ATTENTION: Unused wires in conduit must be grounded at both ends to avoid a possible shock hazard that is caused by induced voltages. Also, if a drive sharing a conduit is being serviced or installed, all drives using this conduit should be disabled to eliminate the possible shock hazard from cross-coupled motor leads. Failure to observe these precautions could result in bodily injury.



ATTENTION: Do not route signal and control wiring with power wiring in the same conduit. This can cause interference with drive operation. Failure to observe these precautions could result in damage to, or destruction of, the equipment.

To connect the AC output power wiring from the drive to the motor:

- ❑ Step 1. Wire the three-phase AC output power motor leads by routing them according to the drive option type. You must punch openings in the option cabinet of the desired conduit size, following NEC, and all applicable local codes and standards.

Do not route more than three sets of motor leads through a conduit. This will minimize cross-talk that could reduce the effectiveness of noise reduction methods. If more than three drive/motor connections per conduit are required, shielded cable must be used. If possible, each conduit should contain only one set of motor leads.

- ❑ Step 2. Connect the three-phase AC output power motor leads to terminals U/T1, V/T2, W/T3 on the power terminal block in the options cabinet.
- ❑ Step 3. Tighten the three-phase AC output power terminals to the proper torque according to drive type as shown in [Table 16](#) or [Table 17](#) on page [189](#).

The following sections describe incoming line components and how to install them. Fuses and an input disconnect are also available as factory-installed options.

Installing an Optional Transformer or Reactor

Input isolation transformers might be needed to help eliminate:

- Damaging AC line voltage transients from reaching the drive.
- Line noise from the drive back to the incoming power source.
- Damaging currents that could develop if a point inside the drive becomes grounded.

Observe these guidelines when installing an isolation transformer:

- A power disconnecting device must be installed between the power line and the primary of the transformer.
- If the user-installed power disconnecting device is a circuit breaker, the circuit breaker trip rating must be coordinated with the inrush current (10...12 times full load current) of the transformer.
- Do not use an input isolation transformer rated more than 1000 kVA for 480V AC (500 kVA for 208V AC) with less than 5% impedance directly ahead of the drive without additional impedance between the drive and the transformer.

[Table 15](#) shows recommended inductance and line reactor ratings.

Table 15 - AC Line Reactors

Drive (Hp)	Line Reactor Inductance ($\pm 10\%$)
2...3	6.5 mH
5	3.0 mH
7.5	2.5 mH
10	1.5 mH
15	1.2 mH
20	0.8 mH
25	0.8 mH
30	0.7 mH
40	0.5 mH
50...60	0.4 mH
75	0.3 mH
100	0.2 mH
125	0.15 mH
150	0.11 mH

Installing Fuses for Branch Circuit Protection

If they were not installed as a factory option, install the required branch circuit protection fuses according to the applicable local, national, and international codes (such as NEC/CEC). The fuses must be installed in the line before the drive input terminals.



ATTENTION: Most codes require that upstream branch protection be provided to protect input power wiring. Failure to observe this precaution could result in severe bodily injury or loss of life.

Installing the Required External/Separate Input Disconnect

An input disconnect must be installed in the line before the drive input terminals in accordance with local, national, and international codes, such as NEC/CEC. If an input disconnect is not installed as a factory option, the disconnect should be sized according to the inrush current as well as any additional loads the disconnect might supply. The trip rating for the inrush current (10...12 times full load current) should be coordinated with that of the input isolation transformer, if used.

Installing Input/Output Power Wiring

Table 16 - Style A Terminals

208V AC Hp	480V AC Hp	Maximum Tightening Torque
Input Power		
3...5	3...10	12 lb•in
7.5...10	15...25	35 lb•in
15...20	30...50	35 lb•in
25...50	60...350	275 lb•in
Output Power		
3...10	3...20	26 lb•in
15...30	25...40	45 lb•in
–	50...60	49.5 lb•in
40...50	75...150	173 lb•in
–	200...250	260 lb•in
–	300...350	354 lb•in

Table 17 - Style B Terminals

208V AC Hp	480V AC Hp	Maximum Tightening Torque
Input Power		
3...5	3...10	12 lb•in
7.5...10	15...25	35 lb•in
15...20	30...50	35 lb•in
25...50	60...350	275 lb•in
Output Power		
3...7.5	3...7.5	13 lb•in
10...20	10...30	19 lb•in
25...30	40...75	40 lb•in
–	100...150	275 lb•in
40...50	200...300	500 lb•in
–	350	375 lb•in

Notes:

Supplemental Information

Specifications

Category	Specification	
Environment	Altitude:	1000 m (3300 ft.) max. without derating
	Surrounding Air Temperature without Derating:	0° C to 40° C (32° F to 104° F)
	Storage Temperature (all const.):	-40° C to 70° C (-40° F to 158° F)
	Relative Humidity:	5% to 95% noncondensing
	Shock:	15 G peak for 11 ms duration (+/- 1.0 ms)
	Vibration:	0.152 mm (0.006 in.) displacement, 1 G peak, 5.5 Hz
All Others	See the PowerFlex® 400 User Manual, publication 22C-UM001	

Notes:

Replacement Parts

Topic	Page
Common Parts	193
Disconnect Parts	194
Bypass Parts	197
Enclosure Parts	199

Common Parts

Components are manufactured by Allen-Bradley except as noted.

Table 1 - Common Parts

Description	Designation	Voltage	Hp	Part Number	
Drive Module	DM1	208V AC	3.0	22C-B012N103	
			5.0	22C-B017N103	
			7.5	22C-B024N103	
			10	22C-B033N103	
			15	22C-B049A103	
			20	22C-B065A103	
			25	22C-B075A103	
			30	22C-B090A103	
			40	22C-B120A103	
			50	22C-B145A103	
			460V AC	3.0	22C-D6P0N103
				5.0	22C-D010N103
				7.5	22C-D012N103
				10	22C-D017N103
		15		22C-D022N103	
		20		22C-D030N103	
		25		22C-D038A103	
		30		22C-D045A103	
		40		22C-D060A103	
		50		22C-D072A103	
		60		22C-D088A103	
		75		22C-D105A103	
		100		22C-D142A103	
		125		22C-D170A103	
		150	22C-D208A103		
		200	22C-D260A103		
		250	22C-D310A103		
		300	22C-D370A103		
350	22C-D460A103				

Table 1 - Common Parts (continued)

Description	Designation	Voltage	Hp	Part Number
Comm Cards	C	All	All	22-COMM-C
	D			22-COMM-D
	E			22-COMM-E
	P			22-COMM-P
	B			22-COMM-B
	L			22-COMM-L
Comm Cover		208V AC	3.0...10	22C-CCC
		460V AC	3.0...20	22C-CCC
Line Reactors	LR	208V AC	3	1321-3R12-A
			5	1321-3R18-A
			7.5	1321-3R25-A
			10	1321-3R35-A
			15	1321-3R45-A
			20	1321-3R55-A
			25	1321-3R80-A
			30	1321-3R100-A
			40...50	1321-3R130-A
			460V AC	3
		5		1321-3R8-B
		7.5		1321-3R12-B
		10		1321-3R18-B
		15		1321-3R25-B
		20...25		1321-3R35-B
		30		1321-3R45-B
		40		1321-3R55-B
		50...60		1321-3R80-B
		75		1321-3R100-B
		100	1321-3R130-B	
125	1321-3R160-B			
150	1321-3R200-B			

Disconnect Parts

Components are manufactured by Allen-Bradley except as noted.

Table 2 - Disconnect Parts for Style A/B Fused Disconnect Packages

Description	Designation	Voltage	Hp	Part Number
Disconnect Switch	DS	208V AC	3.0...5.0	194R-J30-1753
			7.5...10	194R-J60-1753
			15...20	194R-NJ100P3
			25...40	194R-NJ200P3
			50	194R-NJ400P3
		460V AC	3.0...10	194R-J30-1753
			15...25	194R-J60-1753
			30...50	194R-NJ100P3
			60...100	194R-NJ200P3
			125...200	194R-NJ400P3
			250	HLD3500 ⁽¹⁾
			300	HLD3600 ⁽¹⁾
			350	HMDL3700 ⁽¹⁾
			Operator Handle (NEMA/UL Type 1, 12, 3R, 4)	
15...50	194R-HM4			
460V AC	3.0...25	194R-PB		
	30...200	194R-HM4		

Table 2 - Disconnect Parts for Style A/B Fused Disconnect Packages (continued)

Description	Designation	Voltage	Hp	Part Number
Operator Shaft		208V AC	3.0...10	194R-R2
			15...50	194R-R4
		460V AC	3.0...25	194R-R2
			30...100	194R-R4
			125...200	194R-R6
Main Fuses	FU1...FU3	208V AC	3.0	AJT-20 ⁽²⁾
			5.0	AJT-20 ⁽²⁾
			7.5	AJT-35 ⁽²⁾
			10	AJT-40 ⁽²⁾
			15	AJT-80 ⁽²⁾
			20	AJT-100 ⁽²⁾
			25	AJT-125 ⁽²⁾
			30	AJT-150 ⁽²⁾
			40	AJT-200 ⁽²⁾
			50	AJT-250 ⁽²⁾
		460V AC	3.0	AJT-10 ⁽²⁾
			5.0	AJT-15 ⁽²⁾
			7.5...10	AJT-20 ⁽²⁾
			15...20	AJT-35 ⁽²⁾
			25	AJT-60 ⁽²⁾
			30	AJT-70 ⁽²⁾
			40	AJT-80 ⁽²⁾
			50	AJT-100 ⁽²⁾
			60	AJT-150 ⁽²⁾
			75	AJT-175 ⁽²⁾
			100	AJT-200 ⁽²⁾
			125	AJT-250 ⁽²⁾
			150	AJT-350 ⁽²⁾
			200	AJT-400 ⁽²⁾

(1) Manufactured by Cutler Hammer.

(2) Manufactured by Gould-Shawmut.

Table 3 - Disconnect Parts for Style M/N Circuit Breaker Packages

Description	Designation	Voltage	Hp	Part Number
Circuit Breakers	CB1	208V AC	3	EGS3015FFG ⁽¹⁾
			5	EGS3030FFG ⁽¹⁾
			7.5	EGS3040FFG ⁽¹⁾
			10	EGS3050FFG ⁽¹⁾
			15	EGS3080FFG ⁽¹⁾
			20	EGS3100FFG ⁽¹⁾
			25	EGS3125FFG ⁽¹⁾
			30	JGS3150FAG ⁽¹⁾
			40	JGS3200FAG ⁽¹⁾
			50	JGH3225FAG ⁽¹⁾
		460V AC	3.0...5	EGH3015FFG ⁽¹⁾
			7.5	EGH3020FFG ⁽¹⁾
			10	EGH3025FFG ⁽¹⁾
			15	EGH3035FFG ⁽¹⁾
			20	EGH3040FFG ⁽¹⁾
			25	EGH3050FFG ⁽¹⁾
			30	EGH3060FFG ⁽¹⁾
			40	EGH3080FFG ⁽¹⁾
			50	EGH3100FFG ⁽¹⁾
			60	EGH3125FFG ⁽¹⁾
			75	JGH3150FAG ⁽¹⁾
			100	JGH3200FAG ⁽¹⁾
			125	JGH3250FAG ⁽¹⁾
			150	HKD3300 ⁽¹⁾
			200	HKD3350 ⁽¹⁾
250	HLD3500 ⁽¹⁾			
300	HLD3600 ⁽¹⁾			
350	HMDL3700 ⁽¹⁾			
Operator Handle (NEMA/UL Type 1/12) for Enclosure Options A and H		208V AC	3.0...25	EHMVD24B
			30...50	FJHMVD24B
		460V AC	3.0...60	EHMVD24B
			75...125	FJHMVD24B
			150...200	HM3R24
250...350	HM4R24			
Operator Handle (NEMA/UL Type 3R/4) for Enclosure Options X and E		208V AC	3.0...25	EGHMVD24BX
			30...50	JGHMVD24BX
		460V AC	3.0...60	EGHMVD24BX
			75...125	JGHMVD24BX
			150...200	HM3R24X
250...350	HM4R24X			
Terminal Lugs		208V AC	3.0...25	-
			30...50	TA250FJ
		460V AC	3.0...60	-
			75...125	TA250FJ
			150...200	TA350K
			250...300	TA602LDM
350	TA800MA2			

(1) Manufactured by Cutler Hammer.

Bypass Parts

Components are manufactured by Allen-Bradley except as noted.

Table 4 - Bypass Parts for Style B/N Full Feature Bypass Packages

Description	Designation	Voltage	Hp	Part Number			
Bypass Contactor	BC	208V AC	3.0...5.0	100-C23D10			
			7.5...10	100-C37D00			
			15	100-C60D00			
			20	100-C72D00			
			25	100-C85D00			
			30...40	100-D115ED11			
			50	100-D180ED11			
			460V AC	3.0...10	100-C16D10		
		15...20		100-C37D10			
		25...30		100-C43D00			
		40...50		100-C72D00			
		60		100-C85D00			
		75		100-D115ED11			
		100		100-D140ED11			
		125		100-D180ED11			
		150		100-D210ED11			
		200		100-D250ED11			
		250		100-D300ED11			
		300...350		100-D420ED11			
		Input Contactor	DIC	208V AC	3.0...5.0	100-C16D10	
7.5...10	100-C23D10						
15	100-C60D10						
20	100-C72D00						
25...30	100-C85D00						
40	100-D115ED11						
50	100-D140ED11						
460V AC	3.0...10				100-C16D10		
	15...20			100-C23D10			
	25...30			100-C43D00			
	40...50			100-C72D00			
	60			100-C85D00			
	75...100			100-D115ED11			
	125			100-D140ED11			
	150...200			100-D210ED11			
	250			100-D300ED11			
	300...350			100-D420ED11			
	Output Contactor			DOC	208V AC	3.0...7.5	100-C16D10
						10	100-C23D10
15						100-C37D00	
20		100-C43D00					
25...30		100-C72D00					
40...50		100-D115ED11					
460V AC		3.0...20	100-C16D10				
		25...30	100-C37D00				
		40	100-C43D00				
		50...60	100-C72D00				
		75	100-C85D00				
		100...125	100-D115ED11				
		150	100-D140ED11				
		200	100-D210ED11				
		250	100-D300ED11				
		300...350	100-D420ED11				

Table 4 - Bypass Parts for Style B/N Full Feature Bypass Packages (continued)

Description	Designation	Voltage	Hp	Part Number
Contactor Suppressors		230V AC	3.0...30	100-FSV136
		460V AC	3.0...75	100-FSV136
Overload Relay	OL	208V AC	3.0	193-EEDB
			5.0	193-EEEB
			7.5	193-EEED
			10	193-EEED
			15...25	193-EEGE
			30...40	193-EEVF
			50	193-EEJF
			460V AC	3.0
		5.0...7.5		193-EEDB
		10		193-EEEB
		15		193-EEED
		20...30		193-EEFD
		40...60		193-EEGE
		75		193-EEVF
		100...125		193-EEJF
		150	193-EEJG	
200...350	193-EELG			
Bypass Control Panel	CP1	208V AC	3.0...50	SK-C1-BCP1
		460V AC	3.0...350	SK-C1-BCP1
Power Terminal Blocks	T1...T3	208V AC	3.0...7.5	1492-W10
			10...20	1492-W16S
			25...30	1492-J35
			40	67013 ⁽¹⁾
			50	67003
			460V AC	3.0...15
		20...30		1492-W16S
		40...75		1492-J35
		100		67013 ⁽¹⁾
		125...150		67003 ⁽¹⁾
		200...300		69313 ⁽¹⁾
		350	PDB-26-750-1 ⁽²⁾	
Ground Terminal Block	MG	208V AC	3.0...7.5	1492-W10
			10...20	1492-W16S
			25...50	1492-J35
			460V AC	3.0...15
		20...30		1492-W16S
		40...100		1492-J35
		125...350		1492-J70
		Control Terminal Blocks	T31...T40	208V AC
460V AC	3.0...350			1492-W4

(1) Manufactured by Gould-Shawmut.

(2) Manufactured by Ilco.

Enclosure Parts

Table 5 - Enclosure Parts for NEMA/UL Type 1 (Style B only)

Description	Designation	Voltage	Hp	Part Number		
Control Transformer	T1	208V AC	3.0...10	TB-69300 ⁽¹⁾		
			15...30	TB-69301 ⁽¹⁾		
			40...50	TB-69302 ⁽¹⁾		
		460V AC	3.0...20	TB-69300 ⁽¹⁾		
			25...60	TB-69301 ⁽¹⁾		
			75...250	TB-69302 ⁽¹⁾		
			300...350	TA-2-81215 ⁽¹⁾		
		Control Transformer Fuse Holder		208V AC	3.0...30	PL-112700
					40...50	PL-112701
460V AC	3.0...60			PL-112700		
	75...250			PL-112701		
	300...350			PL-112703		
Control Transformer Fuses	FU4...FU5	208V AC	3.0...10	ATQR-1 ⁽²⁾		
			15...30	ATQR-2 ⁽²⁾		
			40...50	ATQR-3 ⁽²⁾		
		480V AC	3.0...60	ATQR-1 ⁽²⁾		
			75...250	ATQR-2 ⁽²⁾		
			300...350	ATQR-3.5 ⁽²⁾		

(1) Manufactured by Acme Electric.

(2) Manufactured by Gould-Shawmut.

Table 6 - Enclosure Parts for NEMA/UL Type 12

Description	Designation	Voltage	Hp	Part Number
Control Transformer	T1	208V AC	3.0...10	TB-69301 ⁽¹⁾
			15...30	TB-69302 ⁽¹⁾
			40...50	TB-69302 (Style A) ⁽¹⁾
			40...50	TB-69303 (Style B) ⁽¹⁾
		460V AC	3.0...15	TA-2-69301 ⁽¹⁾
			20...60	TB-69302 ⁽¹⁾
			75...125	TB-69303 ⁽¹⁾
			150	TB-69305 ⁽¹⁾
Control Transformer Fuse Holder		208V AC	3.0...10	PL-112700 ⁽¹⁾
			15...50	PL-112701 ⁽¹⁾
		460V AC	3.0...15	PL-112700 ⁽¹⁾
			20...60	PL-112701 ⁽¹⁾
			75...125	PL-112702 ⁽¹⁾
			150	PL-112704 ⁽¹⁾
Control Transformer Primary Fuses	FU4...FU5	208V AC	3.0...10	ATQR-1.5
			15...30	ATQR-2
			40...50	ATQR-2 (Style A)
			40...50	ATQR-3 (Style B)
		460V AC	3.0...60	ATQR-1
			75...125	ATQR-1.5
			150	ATQR-3.5
Control Circuit Fan Fuse Holder		208V AC	3.0...50	BM6031PQ
		460V AC	3.0...150	BM6031PQ

Table 6 - Enclosure Parts for NEMA/UL Type 12 (continued)

Description	Designation	Voltage	Hp	Part Number			
Control Circuit Fan Fuse	FU6	208V AC	3.0...10	FNM-1			
			15...30	FNM-1.4			
			40...50	FNM-1.4 (Style A)			
			40...50	FNM-2 (Style B)			
		460V AC	3.0...60	FNM-1			
			75...125	FNM-3.2			
150	FNM-5						
Fan and Filter	-	208V AC	3.0...7.5	PF42500 ⁽²⁾			
			10...20	PF43000 ⁽²⁾			
			25...50	PF65000 ⁽²⁾			
		460V AC	3.0...15	PF42500 ⁽²⁾			
			20...40	PF43000 ⁽²⁾			
			50, 60 and 125	PF65000 ⁽²⁾			
			75	PF66000 ⁽²⁾			
			100 and 150	PF67000 ⁽²⁾			
			Exhaust Filter w/Grille		208V AC	3.0...20	PFA4000 ⁽²⁾
						25...50	PFA6000 ⁽²⁾
460V AC	3.0...40	PFA4000 ⁽²⁾					
	50...150	PFA6000 ⁽²⁾					
Filter Media		208V AC	3.0...20	18611600036 ⁽²⁾			
			25...50	18611600037 ⁽²⁾			
		460V AC	3.0...40	18611600036 ⁽²⁾			
			50...150	18611600037 ⁽²⁾			

(1) Manufactured by Acme Electric.

(2) Manufactured by Pfannenberglnc.

Table 7 - Enclosure Parts for NEMA/UL Type 3R

Description	Designation	Voltage	Hp	Part Number
Control Transformer	T1	208V AC	3.0...30	TB-69302 ⁽¹⁾
			45...50	TB-69303 ⁽¹⁾
		460V AC	3.0...40	TB-69302 ⁽¹⁾
			50...150	TB-69303 ⁽¹⁾
Control Transformer Fuse Holder		208V AC	3.0...30	PL-112701 ⁽¹⁾
			40...50	PL-112702 ⁽¹⁾
		460V AC	3.0...40	PL-112701 ⁽¹⁾
			50...150	PL-112702 ⁽¹⁾
Control Transformer Primary Fuses	FU4...FU5	208V AC	3.0...30	ATQR-2
			40...50	ATQR-3.5
		460V AC	3.0...40	ATQR-1
50...150	ATQR-1.5			
Control Circuit Fan Fuse Holder		208V AC	3.0...50	BM6031PQ
		460V AC	3.0...5.0	No Fan
			7.5...150	BM6031PQ
Control Circuit Fan Fuse	FU6	208V AC	3.0...50	FNM-1
		460V AC	3.0...100	FNM-1
			125...150	FNM-2

Table 7 - Enclosure Parts for NEMA/UL Type 3R (continued)

Description	Designation	Voltage	Hp	Part Number
Fan and Filter		208V AC	3.0...10	SCE-FA44 ⁽²⁾
			15...30	SCE-FA66 ⁽²⁾
			40...50	SCE-FA1010 ⁽²⁾
		460V AC	3.0...5.0	No Fan
			7.5...20	SCE-FA44 ⁽²⁾
			25...40	SCE-FA66 ⁽²⁾
50...150	SCE-FA1010 ⁽²⁾			
Exhaust Filter w/Grille		208V AC	3.0...10	SCE-FGA44 ⁽²⁾
			15...30	SCE-FGA66 ⁽²⁾
			40...50	SCE-FGA1010 ⁽²⁾
		460V AC	3.0...5.0	No Filter
			7.5...20	SCE-FGA44 ⁽²⁾
			25...40	SCE-FGA66 ⁽²⁾
50...150	SCE-FGA1010 ⁽²⁾			
Filter Media		208V AC	3.0...10	SCE-RF44 ⁽²⁾
			15...20	SCE-RF66 ⁽²⁾
			25...50	SCE-RF1010 ⁽²⁾
		460V AC	3.0...5.0	No Filter
			7.5...20	SCE-RF44 ⁽²⁾
			25...40	SCE-RF66 ⁽²⁾
50...150	SCE-RF1010 ⁽²⁾			
Control Circuit Heater Fuse Holder		208V AC	3.0...50	BM6031PQ
		460V AC	3.0...150	BM6031PQ
Control Circuit Heater Fuse	FU7	208V AC	3.0...20	FNM-2
			25...50	FNM-3.2
		460V AC	3.0...40	FNM-2
			50...150	FNM-3.2
Heater		208V AC	3.0...20	D-AH1001A ⁽³⁾
			25...50	D-AH2001A ⁽³⁾
		460V AC	3.0...40	D-AH1001A ⁽³⁾
			50...150	D-AH2001A ⁽³⁾

- (1) Manufactured by Acme Electric.
- (2) Manufactured by Saginaw Control and Engineering
- (3) Manufactured by Hoffman Enclosures Inc.

Table 8 - Enclosure Parts for NEMA/UL Type 4

Description	Designation	Voltage	Hp	Part Number
Control Transformer	T1	208V AC	3.0...20	TA-2-54525 ⁽¹⁾
			25...30	TA-2-81202 ⁽¹⁾
			40...50	TA-2-81203 ⁽¹⁾
		460V AC	3.0...5.0	TA-2-69302 ⁽¹⁾
			7.5...40	TA-2-54525 ⁽¹⁾
			50...60	TA-2-81202 ⁽¹⁾
			75...100	TA-2-81203 ⁽¹⁾
			125...150	TA-2-69303 ⁽¹⁾
		Control Transformer Fuse Holder		208V AC
40...50	PL-112707 ⁽¹⁾			
460V AC	3.0...5.0			PL-112701 ⁽¹⁾
	7.5...60			PL-112706 ⁽¹⁾
	75...100			PL-112707 ⁽¹⁾
125...150	PL-112702 ⁽¹⁾			
Control Transformer Primary Fuses	FU4...FU5	208V AC	3.0...20	ATQR-12
			25...30	ATQR-15
			40...50	ATQR-20
		460V AC	3.0...5.0	ATQR-1
			7.5...40	ATQR-5
			50...60	ATQR-7.5
			75...100	FRS-R-12
			100...150	ATQR-1.5
Air Conditioner		208V AC	3.0...10	IQ1800VS-126 ⁽²⁾
			15...20	IQ3000VS-126 ⁽²⁾
			25...30	IQ5000V16-126 ⁽²⁾
			40...50	IQ8000V16-126 ⁽²⁾
		460V AC	3.0...5.0	No Air Conditioner
			7.5...20	IQ1800VS-126 ⁽²⁾
			25...40	IQ3000VS-126 ⁽²⁾
			50...60	IQ5000V16-126 ⁽²⁾
			75...100	IQ8000V16-126 ⁽²⁾
			125...150	DTS 3361 ⁽³⁾
Control Circuit Air Conditioner Fuse Holder		208V AC	3.0...50	BM6031PQ
		460V AC	3.0...5.0	No Air Conditioner
			7.5...100	BM6031PQ
			125...150	BC6033P
Control Circuit Air Conditioner Fuse	FU8	208V AC	3.0...20	FNM-10
			25...30	FNM-12
			40...50	FNM-20
		460V AC	3.0...5.0	No Fuse
			7.5...40	FNM-10
			50...60	FNM-12
			75...100	FNM-20
			125...150	ATQR-10

Table 8 - Enclosure Parts for NEMA/UL Type 4 (continued)

Description	Designation	Voltage	Hp	Part Number
Air Conditioner Filter Media		208V AC	3.0	No Filter
			5.0...50	Media is washable
		460V AC	3.0...5.0	No Filter
			7.5...20	Media is washable
			25	POF1019-GAL ⁽²⁾
			30...100	Media is washable
125...150	18881500002 ⁽³⁾			
Control Circuit Heater Fuse Holder		208V AC	3.0...50	BM6031PQ
		460V AC	3.0...150	BM6031PQ
Control Circuit Heater Fuse	FU7	208V AC	3.0...20	FNM-2
			25...50	FNM-3.2
		460V AC	3.0...40	FNM-2
			50...150	FNM-3.2
Heater		208V AC	3.0...30	D-AH1001A ⁽⁴⁾
			40...50	D-AH2001A ⁽⁴⁾
		460V AC	3.0...60	D-AH1001A ⁽⁴⁾
			75...150	D-AH2001A ⁽⁴⁾

(1) Manufactured by Acme Electric.

(2) Manufactured by Ice Qube Inc.

(3) Manufactured by Pfannenberg Inc.

(4) Manufactured by Hoffman Enclosures Inc.

Notes:

History of Changes

This appendix summarizes the revisions to this manual. Reference this appendix if you need information to determine what changes have been made across multiple revisions. This may be especially useful if you are deciding to upgrade your hardware or software based on information added with previous revisions of this manual.

23C-IN001B-EN-P, June 2013

Change

Removed all content related to the discontinued 3 Contactor Basic Bypass with Disconnect Package (Style C)

23C-IN001C-EN-P, November 2015

Topic

Updated the schematic drawings for the following drive packages to include the new circuit breaker:

- 200 Hp, 460V AC Drives (Sheet 1 of 2) - NEMA/UL Type 1
- 200 Hp, 460V AC Drives (Sheet 2 of 2) - NEMA/UL Type 1
- 250...350 Hp, 460V AC Drives (Sheet 1 of 2) - NEMA/UL Type 1
- 250...350 Hp, 460V AC Drives (Sheet 2 of 2) - NEMA/UL Type 1
- 3.0...50 Hp, 208V AC and 3.0...150 Hp, 460V AC Drives (Sheet 1 of 2) - NEMA/UL Type 3R
- 3.0...50 Hp, 208V AC and 3.0...150 Hp, 460V AC Drives (Sheet 2 of 2) - NEMA/UL Type 3R

Updated the layout drawings for the following drive packages to include the new circuit breaker:

- 3.0...5.0 Hp, 208V AC and 3.0...10 Hp, 460V AC Drives - NEMA/UL Type 1
- 7.5...10 Hp, 208V AC and 15...20 Hp, 460V AC Drives - NEMA/UL Type 1
- 25...30 Hp, 208V AC Drives - NEMA/UL Type 1
- 50...75 Hp, 460V AC Drives - NEMA/UL Type 1
- 40 Hp, 208V AC and 100 Hp, 460V AC Drives - NEMA/UL Type 1
- 50 Hp, 208V AC Drives - NEMA/UL Type 1
- 125...150 Hp, 460V AC Drives - NEMA/UL Type 1
- 200...250 Hp, 460V AC Drives - NEMA/UL Type 1
- 300...350 Hp, 460V AC Drives - NEMA/UL Type 1
- 3.0...5.0 Hp, 208V AC and 3.0...10 Hp, 460V AC Drives with Line Reactor - NEMA/UL Type 1
- 7.5...10 Hp, 208V AC and 15...20 Hp, 460V AC Drives with Line Reactor - NEMA/UL Type 1
- 15...20 Hp, 208V AC and 25...40 Hp, 460V AC Drives with Line Reactor - NEMA/UL Type 1
- 25 Hp, 208V AC Drives with Line Reactor - NEMA/UL Type 1
- 30 Hp, 208V AC Drives with Line Reactor - NEMA/UL Type 1
- 50...60 Hp, 460V AC Drives with Line Reactor - NEMA/UL Type 1
- 40...50 Hp, 208V AC and 75...100 Hp, 460V AC Drives with Line Reactor - NEMA/UL Type 1

Added new 460V AC, 250 Hp, 300 Hp, and 350 Hp disconnect switch part numbers to the Disconnect Parts table for the Style Allen-Bradley Fused Disconnect Packages.

Added new 208V AC and 460V AC circuit breaker part numbers to the Disconnect Parts table for the Style M/N Circuit Breaker Packages.

Added new operator handle kit part numbers to the Disconnect Parts table for the Style M/N Circuit Breaker Packages.

Added new terminal lug part numbers to the Disconnect Parts table for the Style M/N Circuit Breaker Packages.

Add new Appendix C - History of Changes

Notes:

Rockwell Automation Support

Use the following resources to access support information.

Technical Support Center	Knowledgebase Articles, How-to Videos, FAQs, Chat, User Forums, and Product Notification Updates.	https://rockwellautomation.custhelp.com/
Local Technical Support Phone Numbers	Locate the phone number for your country.	http://www.rockwellautomation.com/global/support/get-support-now.page
Direct Dial Codes	Find the Direct Dial Code for your product. Use the code to route your call directly to a technical support engineer.	http://www.rockwellautomation.com/global/support/direct-dial.page
Literature Library	Installation Instructions, Manuals, Brochures, and Technical Data.	http://www.rockwellautomation.com/global/literature-library/overview.page
Product Compatibility and Download Center (PCDC)	Get help determining how products interact, check features and capabilities, and find associated firmware.	http://www.rockwellautomation.com/global/support/pcdc.page

Documentation Feedback

Your comments will help us serve your documentation needs better. If you have any suggestions on how to improve this document, complete the How Are We Doing? form at http://literature.rockwellautomation.com/idc/groups/literature/documents/du/ra-du002_-en-e.pdf.

Rockwell Automation maintains current product environmental information on its website at <http://www.rockwellautomation.com/rockwellautomation/about-us/sustainability-ethics/product-environmental-compliance.page>.

Allen-Bradley, PowerFlex, Rockwell Automation, and Rockwell Software are trademarks of Rockwell Automation, Inc.

ControlNet, DeviceNet, and EtherNet/IP are trademarks of ODVA, Inc.

Trademarks not belonging to Rockwell Automation are property of their respective companies.

Rockwell Otomasyon Ticaret A.Ş., Kar Plaza İş Merkezi E Blok Kat:6 34752 İçerenköy, İstanbul, Tel: +90 (216) 5698400

www.rockwellautomation.com

Power, Control and Information Solutions Headquarters

Americas: Rockwell Automation, 1201 South Second Street, Milwaukee, WI 53204-2496 USA, Tel: (1) 414.382.2000, Fax: (1) 414.382.4444

Europe/Middle East/Africa: Rockwell Automation NV, Pegasus Park, De Kleetlaan 12a, 1831 Diegem, Belgium, Tel: (32) 2 663 0600, Fax: (32) 2 663 0640

Asia Pacific: Rockwell Automation, Level 14, Core F, Cyberport 3, 100 Cyberport Road, Hong Kong, Tel: (852) 2887 4788, Fax: (852) 2508 1846



PN-564176

PN-564176

Publication 23C-IN001D-EN-P - November 2019

Supersedes Publication 23C-IN001C-EN-P - November 2015

Copyright © 2019 Rockwell Automation, Inc. All rights reserved. Printed in the U.S.A.