

Absolute encoders - singleturn

**Motor-Line
optical**

Sendix 5873 (tapered shaft)

SSI / BiSS (+incremental)

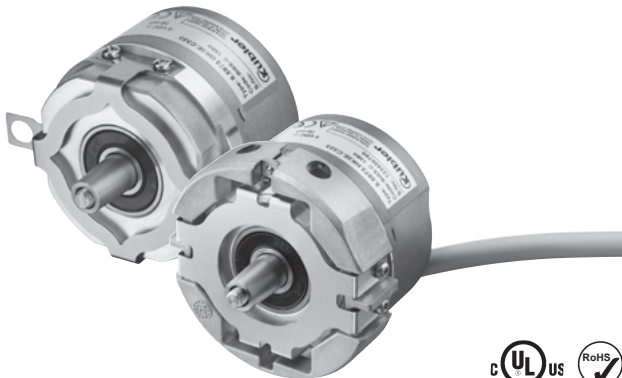

The optical Sendix 5873 singleturn encoders with SSI or BiSS interface and optional 2048 ppr SinCos incremental track reach a resolution of up to 21 bits.

Advantages: Plug-and-Play for commissioning, including electronic data sheet and possibility to set the absolute measuring system to a predefined position value.

Specially designed for mounting on direct drives in the elevator technology.



Electronic data sheet



Safety-Lock™

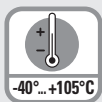

Temperature range
-40°...+105°C



High protection level
IP



High shaft load capacity



Shock / vibration resistant



Magnetic field proof



Short-circuit proof



Reverse polarity protection

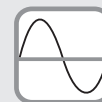

SinCos



Optical sensor

Reliable and insensitive

- Sturdy bearing construction in Safety-Lock™ design for resistance against vibration and installation errors.
- Encoder specially designed for mounting on direct drives in the elevator technology.

Versatile

- High-precision with a data refresh rate of the position value $\leq 1\mu\text{s}$.
- High-resolution feedback in real-time via 21 bit fully digital or incremental outputs SinCos and RS422.
- BiSS-C BP3 encoder profile.
- Short control cycles, clock rate with SSI up to 2 MHz / with BiSS up to 10 MHz.

Order code Tapered shaft

8.5873 . **XKXX** . **XX2X**
Type a b c d e f g h

a Flange

G = with stator coupling, IP65, \varnothing 72 mm [2.83"]
H = with expanding coupling, IP65, \varnothing 65 mm [2.56"]

b Tapered shaft

K = \varnothing 10 mm [0.39"]

c Interface / power supply

1 = SSI, BiSS / 5 V DC
2 = SSI, BiSS / 10 ... 30 V DC
3 = SSI, BiSS + 2048 ppr. SinCos / 5 V DC
4 = SSI, BiSS + 2048 ppr. SinCos / 10 ... 30 V DC
5 = SSI, BiSS / 5 V DC, with sensor output
6 = SSI, BiSS + 2048 ppr. SinCos / 5 V DC, with sensor output
9 = SSI, BiSS + 2048 ppr. RS422 (TTL-comp.) / 5 V DC, with sensor output
E = SSI, BiSS + 2048 ppr. SinCos / 4,5 ... 5,5 V DC, with sensor output¹⁾

d Type of connection

E = tangential cable, 1 m PVC
F = tangential cable, length PVC see below *)
G = tangential cable, with Sub-D connector (male contact, 15-pin, double-row), length PVC s. below *)²⁾
H = tangential cable, with Phoenix Contact connector (MC1.5/16-STF-3.81), length PVC s. below *)²⁾

*) Available lengths (connection types F, G, H):
2, 3, 5, 8, 10, 15 m [5.56, 9.84, 16.40, 26.25, 32.80, 49.21']
order code expansion .XXXX = length in dm
ex.: 8.5873.GK2E.G323.0030 (for cable length 3 m)

e Code

B = SSI, binary
C = BiSS, binary
G = SSI, gray

f Resolution³⁾

A = 10 bit
1 = 11 bit
2 = 12 bit
3 = 13 bit
4 = 14 bit
7 = 17 bit
C = 21 bit⁴⁾

g Inputs / outputs³⁾

2 = SET, DIR input
additional status output

h Options (service)

1 = no option
2 = status LED
3 = SET button and status LED

1) Without reverse polarity protection.

2) Can be combined as a standard only with interface E (other variants on request).

3) Resolution, preset value and counting direction factory-programmable.

4) Only in conjunction with interface 1 or 2 and code C.

Absolute encoders - singleturn

Motor-Line optical	Sendix 5873 (tapered shaft)	SSI / BiSS (+incremental)
---------------------------	------------------------------------	----------------------------------

Technical data

Mechanical characteristics		
Maximum speed hollow shaft version	IP65 up to 70°C [158°F]	9000 min ⁻¹ , 6000 min ⁻¹ (continuous)
	IP65 up to T _{max}	6000 min ⁻¹ , 3000 min ⁻¹ (continuous)
Starting torque at 20°C [68°F]	< 0.01 Nm	
Mass moment of inertia	6.0 x 10 ⁻⁶ kgm ²	
Load capacity of shaft	radial	80 N
	axial	40 N
Weight	approx. 0.35 kg [12.35 oz]	
Protection acc. to EN 60529	housing side	IP67
	shaft side	IP65
Working temperature range	-40°C ... +90°C [-40°F ... +194°F] (+105°C [+212°F] with interface E) ¹⁾	
Materials	tapered shaft	stainless steel
	flange	aluminium
	housing	zinc die-cast
	cable	PVC
Shock resistance acc. EN 60068-2-27	2500 m/s ² , 6 ms	
Vibration resistance acc. EN 60068-2-6	100 m/s ² , 55 ... 2000 Hz	

Electrical characteristics		
Power supply	5 V DC (+5 %) or 10 ... 30 V DC	
Current consumption (no load)	5 V DC	max. 70 mA
	10 ... 30 V DC	max. 45 mA
Reverse polarity protection of the power supply	yes (not for interface E)	
Short circuit proof outputs	yes ²⁾	
UL approval	file 224618	
CE compliant acc. to	EMC guideline 2004/108/EC RoHS guideline 2011/65/EU	

SSI interface		
Output driver	RS485 transceiver type	
Permissible load / channel	max. +/- 20 mA	
Signal level	HIGH	typ. 3.8 V
	LOW at I _{Load} = 20 mA	typ. 1.3 V
Resolution	10 ... 14 bit and 17 bit	
Code	binary or gray	
SSI clock rate	50 kHz ... 2 MHz	
Monoflop time	≤ 15 μs	
Note:	If the clock starts cycling within the monoflop time, a second data transfer starts with the same data. If the clock starts cycling after the monoflop time, the data transfer starts with the new values. The update rate is dependent on the clock speed, data length and monoflop-time.	
Data refresh rate	resolution ≤ 14 bit	≤ 1 μs
	resolution ≥ 15 bit	4 μs

BiSS interface		
Output driver	RS485 transceiver type	
Permissible load / channel	max. +/- 20 mA	
Signal level	HIGH	typ. 3.8 V
	LOW at I _{Load} = 20 mA	typ. 1.3 V
Resolution	10 ... 14 bit; 17, 19 and 21 bit	
Code	binary	
Clock rate	50 kHz ... 10 MHz	
Max. update rate	< 15 μs, depends on the clock rate and the data length	
Data refresh rate	< 1 μs	
Protocol	BiSS-C BP3 encoder profile	
Note:	<ul style="list-style-type: none"> - Bidirectional, factory programmable parameters are: resolution, code, direction, alarms and warnings - CRC data verification - EDS (electronic data sheet) 	

SET input or SET button		
Input	active HIGH	
Input type	comparator	
Signal level	HIGH	min: 60 % of +V (power supply) max: +V
	LOW	max: 25 % of +V (power supply)
Input current	< 0.5 mA	
Min. pulse duration (SET)	10 ms	
Timeout after SET signal	14 ms	
Response time (DIR input)	1 ms	
<p>The encoder can be set to zero at any position by means of a HIGH signal on the SET input or by pressing the optional SET button (with a pencil, ball-point pen or similar).</p> <p>Other preset values can be factory-programmed. The SET input has a signal processing time of approx. 1 ms. Once the SET function has been triggered, the encoder requires an internal processing time of approx. 15 ms before the new position data can be read. During this time the status output is at LOW.</p>		

Status output and LED		
Output driver	open collector, internal pull up resistor 22 kOhm	
Permissible load	max. 20 mA	
Signal level	HIGH	+V
	LOW	< 1 V
Active	LOW	
<p>The optional LED (red) and the status output serve to display various alarm or error messages. In normal operation the LED is OFF and the status output is HIGH (Open Collector with int. pull-up 22 kOhm).</p> <p>An active status output (LOW) displays:</p> <ul style="list-style-type: none"> - Sensor error, singleturn or multiturn (soiling, glass breakage etc.) - LED fault (failure or ageing) - over- or under-temperature <p>In the SSI mode, the fault indication can only be reset by switching off the power supply to the device.</p>		

1) Temperature measured on the flange – max. 80°C allowable on the cable (fixed installation).
2) Short circuit to 0 V or to output, one channel at a time, power supply correctly applied.

Absolute encoders - singleturn

Motor-Line optical	Sendix 5873 (tapered shaft)	SSI / BiSS (+incremental)
---------------------------	------------------------------------	----------------------------------

Option incremental outputs (A/B), 2048 ppr		
	SinCos	RS422 TTL compatible
Max. frequency -3dB	400 kHz	400 kHz
Signal level	1 V _{pp} (±20 %)	HIGH: min. 2.5 V LOW: max. 0.5 V
Short circuit proof	yes	yes

DIR input
A HIGH signal switches the direction of rotation from the default CW to CCW. This function can also be factory-programmed to be inverted. If DIR is changed when the device is already switched on, then this will be interpreted as an error. The LED will come ON and the status output will switch to LOW.

Power-ON time
After Power-ON the encoder requires a time of approx. 150 ms before valid data can be read.
Hot plugging of the encoder should be avoided.

Terminal assignment

Interface	Type of connection	Features	Cable (isolate unused wires individually before initial start-up)
1, 2	E, F	SET, DIR, Status	Signal: 0 V +V C+ C- D+ D- SET DIR Stat N/C N/C N/C \perp
			Cable colour: WH BN GN YE GY PK BU RD BK - - - shield
5	E, F	SET, DIR, Status sensor output	Signal: 0 V +V C+ C- D+ D- SET DIR Stat N/C 0Vsens +Vsens \perp
			Cable colour: WH BN GN YE GY PK BU RD BK - GY-PK RD-BU shield
3, 4	E, F	SET, DIR, SinCos oder incr. RS422	Signal: 0 V +V C+ C- D+ D- SET DIR A \bar{A} B \bar{B} \perp
			Cable colour: WH BN GN YE GY PK BU RD BK VT GY-PK RD-BU shield
6, 9, E	E, F	SinCos or incr. RS422 sensor output	Signal: 0 V +V C+ C- D+ D- A \bar{A} B \bar{B} 0Vsens +Vsens \perp
			Cable colour: WH BN GN YE GY PK BU RD BK VT GY-PK RD-BU shield
E	H	SinCos sensor output	Tangential cable, with Phoenix Contact connector (MC1.5/16-STF-3.81), 16-pin
			Signal: +V +Vsens 0 V 0Vsens N/C A \bar{A} B \bar{B} C+ C- D+ D- N/C N/C N/C Pin: 1 2 3 4 5 6 7 8 9 10 11 12 13 14 15 16
E	G	SinCos sensor output	Tangential cable, with Sub-D connector (male contact), 15-pin
			Signal: A 0 V B +V D+ - - C+ \bar{A} 0Vsens \bar{B} +Vsens D- - C- \perp Pin: 1 2 3 4 5 6 7 8 9 10 11 12 13 14 15

- +V: Encoder power supply +V DC
- 0 V: Encoder power supply ground GND (0 V)
- 0 Vsens / +Vsens: Using the sensor outputs of the encoder, the voltage present can be measured and if necessary increased accordingly.
- C+, C-: Clock signal
- D+, D-: Data signal
- A, \bar{A} : Incremental output channel A (cosine)
- B, \bar{B} : Incremental output channel B (sine)
- SET: Set input. The current position becomes defined as position zero.
- DIR: Direction input. If this input is active, output values are counted backwards (decrease) when the shaft is turning clockwise.
- Stat: Status output
- PH \perp : Plug connector housing (shield)

Top view of mating side, male contact base



Phoenix Contact connector (MC1.5/16-STF-3.81), 16-pin

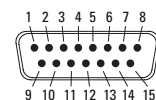

Sub-D connector (male contact), 2-reihig, 15-pin

Absolute encoders - singleturn

Motor-Line optical	Sendix 5873 (tapered shaft)	SSI / BiSS (+incremental)
-------------------------------	------------------------------------	----------------------------------

Dimensions tapered shaft version

Dimensions in mm [inch]

Flange with stator coupling, \varnothing 72 [2.83]

Flange type G

(with tapered shaft K and tangential cable)

- 1 Status-LED
- 2 SET button

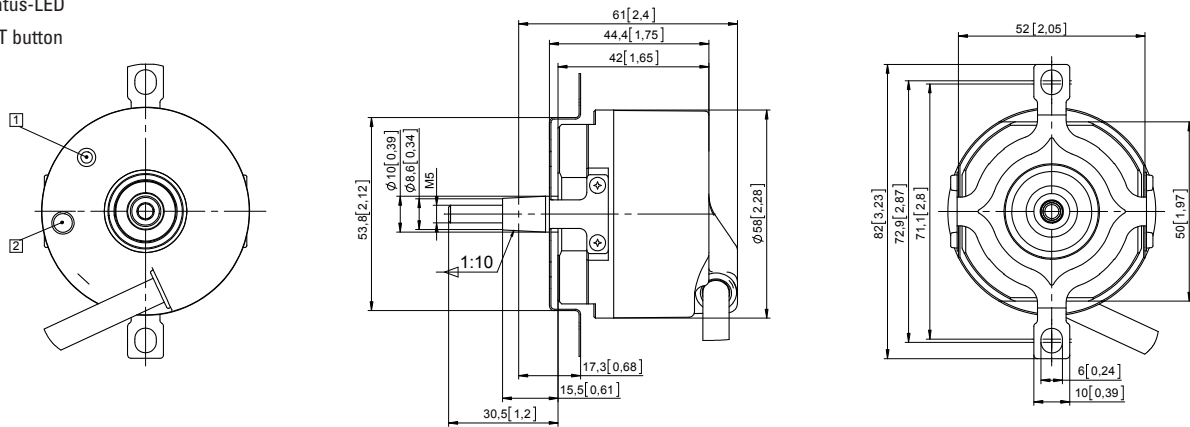

Flange with expanding coupling, \varnothing 65 [2.56"]

Flange type H

- 1 Recommended torque for (SW 2) tightening screw 1 Nm
- 2 Recommended torque for (SW 4) tightening screw 3 ± 0.5 Nm
- 3 Status-LED
- 4 SET button

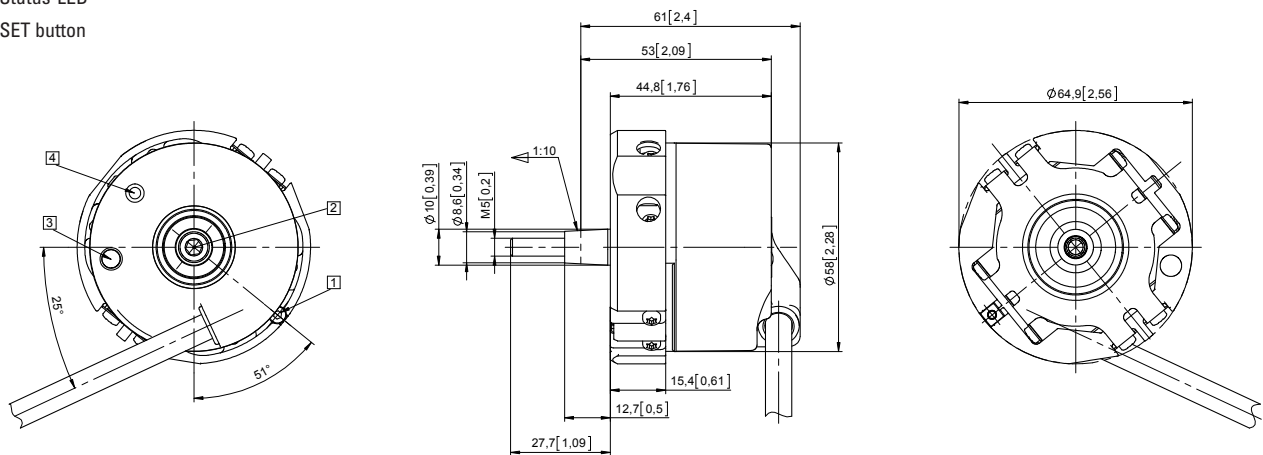

Absolute encoders
singleturn